



Project No. 0601-012-11-01
January 19, 2024

Kelly Keel
Executive Director
Texas Commission on Environmental Quality
12100 Park 35 Circle, MC-109
Austin, Texas 78753

Re: San Antonio Transfer Station
Type V Permit Application
Bexar County, Texas

Dear Kelly Keel:

On behalf of Lealco, Inc. (Lealco), an affiliate of Waste Connections, Inc. (WC), please find enclosed a Permit Application for the proposed San Antonio Transfer Station. Included are three copies of the application for your technical review.

The San Antonio Transfer Station (TS) is a proposed Type V municipal solid waste (MSW) processing facility to be located in Bexar County, Texas. The proposed facility address is 10244 FM 1346, Adkins, Texas 78101 in Bexar County.

The San Antonio TS will provide an efficient means to transfer MSW that is generated in the City of San Antonio, Bexar County, and the surrounding areas to a Texas Commission on Environmental Quality (TCEQ) permitted MSW landfill. The transfer station will have a proposed capacity of 2,500 tons per day.

It is requested that this permit application be processed per Title 30 TAC §330.9(b)(3). Lealco is fully committed to operating the San Antonio Transfer Station consistent with TCEQ rules and regulations in order protect human health and the environment.

We appreciate your technical review of this Permit application. If you have any questions, please do not hesitate to contact me.

Sincerely,
Weaver Consultants Group, LLC



Charles R. Marsh, P.E.
Project Director

Enclosures: Permit Application (3 copies)

cc: Brett O'Connor, Lealco, Inc.
Gary Bartels, Lealco, Inc.
Dillon Hoppe, Lealco, Inc.
TCEQ, Region 13

CONTENTS

PART I APPLICATION FORM
TCEQ Core Data Form
Plain Language Summary

PARTS I/II GENERAL APPLICATION REQUIREMENTS

PART III FACILITY DESIGN REPORT

PART IV SITE OPERATING PLAN





TCEQ Core Data Form

For detailed instructions on completing this form, please read the Core Data Form Instructions or call 512-239-5175.

SECTION I: General Information

1. Reason for Submission (If other is checked please describe in space provided.)		
<input checked="" type="checkbox"/> New Permit, Registration or Authorization (Core Data Form should be submitted with the program application.)		
<input type="checkbox"/> Renewal (Core Data Form should be submitted with the renewal form)	<input type="checkbox"/> Other	
2. Customer Reference Number (if issued)	Follow this link to search for CN or RN numbers in Central Registry**	3. Regulated Entity Reference Number (if issued)
CN 600321871		RN 111892352

SECTION II: Customer Information

4. General Customer Information		5. Effective Date for Customer Information Updates (mm/dd/yyyy)		07/12/2024	
<input type="checkbox"/> New Customer		<input checked="" type="checkbox"/> Update to Customer Information		<input type="checkbox"/> Change in Regulated Entity Ownership	
<input type="checkbox"/> Change in Legal Name (Verifiable with the Texas Secretary of State or Texas Comptroller of Public Accounts)					
<i>The Customer Name submitted here may be updated automatically based on what is current and active with the Texas Secretary of State (SOS) or Texas Comptroller of Public Accounts (CPA).</i>					
6. Customer Legal Name (If an individual, print last name first: eg: Doe, John)				<i>If new Customer, enter previous Customer below:</i>	
Waste Connections Lone Star, Inc.					
7. TX SOS/CPA Filing Number		8. TX State Tax ID (11 digits)		9. Federal Tax ID	10. DUNS Number (if applicable)
0131598000		17528265251		(9 digits) 752826525	
11. Type of Customer:		<input checked="" type="checkbox"/> Corporation		<input type="checkbox"/> Individual	Partnership: <input type="checkbox"/> General <input type="checkbox"/> Limited
Government: <input type="checkbox"/> City <input type="checkbox"/> County <input type="checkbox"/> Federal <input type="checkbox"/> Local <input type="checkbox"/> State <input type="checkbox"/> Other		<input type="checkbox"/> Sole Proprietorship		<input type="checkbox"/> Other:	
12. Number of Employees				13. Independently Owned and Operated?	
<input type="checkbox"/> 0-20 <input type="checkbox"/> 21-100 <input type="checkbox"/> 101-250 <input type="checkbox"/> 251-500 <input checked="" type="checkbox"/> 501 and higher				<input checked="" type="checkbox"/> Yes <input type="checkbox"/> No	
14. Customer Role (Proposed or Actual) – as it relates to the Regulated Entity listed on this form. Please check one of the following					
<input type="checkbox"/> Owner		<input type="checkbox"/> Operator		<input checked="" type="checkbox"/> Owner & Operator	
<input type="checkbox"/> Occupational Licensee		<input type="checkbox"/> Responsible Party		<input type="checkbox"/> VCP/BSA Applicant	
<input type="checkbox"/> Other:					
15. Mailing Address:		3 Hughes Landing, 8 th Floor			
City		The Woodlands		State	TX
ZIP		77381		ZIP + 4	
16. Country Mailing Information (if outside USA)				17. E-Mail Address (if applicable)	
				bretto@wasteconnections.com	

18. Telephone Number	19. Extension or Code	20. Fax Number (if applicable)
(620) 778-2039		() -

SECTION III: Regulated Entity Information

21. General Regulated Entity Information (If 'New Regulated Entity' is selected, a new permit application is also required.)								
<input checked="" type="checkbox"/> New Regulated Entity <input type="checkbox"/> Update to Regulated Entity Name <input type="checkbox"/> Update to Regulated Entity Information								
<i>The Regulated Entity Name submitted may be updated, in order to meet TCEQ Core Data Standards (removal of organizational endings such as Inc, LP, or LLC).</i>								
22. Regulated Entity Name (Enter name of the site where the regulated action is taking place.)								
San Antonio Transfer Station								
23. Street Address of the Regulated Entity: (No PO Boxes)	10244 Farm to Market 1346							
	City	San Antonio	State	TX	ZIP	78101	ZIP + 4	
24. County	Bexar							

If no Street Address is provided, fields 25-28 are required.

25. Description to Physical Location:	The site will be accessed from 1346, which is approximately 3.7 miles south of the intersection of Interstate 10 & FM 1604 and then 1.5 miles west of intersection FM 1604 and FM 1346.								
26. Nearest City	San Antonio				State	TX	Nearest ZIP Code		78101
<i>Latitude/Longitude are required and may be added/updated to meet TCEQ Core Data Standards. (Geocoding of the Physical Address may be used to supply coordinates where none have been provided or to gain accuracy).</i>									
27. Latitude (N) In Decimal:	29.42			28. Longitude (W) In Decimal:	98.288333				
Degrees	Minutes	Seconds	Degrees	Minutes	Seconds				
29	25	12	98	17	18				
29. Primary SIC Code	30. Secondary SIC Code		31. Primary NAICS Code		32. Secondary NAICS Code				
(4 digits)	(4 digits)		(5 or 6 digits)		(5 or 6 digits)				
4212			423930						
33. What is the Primary Business of this entity? (Do not repeat the SIC or NAICS description.)									
Solid Waste Processing, Storage, & Transfer									
34. Mailing Address:	3 Hughes Landing, 8 th Floor								
	City	The Woodlands	State	TX	ZIP	77381	ZIP + 4		
35. E-Mail Address:	bretto@wasteconnections.com								
36. Telephone Number	37. Extension or Code			38. Fax Number (if applicable)					
(620) 778-2039				() -					

39. TCEQ Programs and ID Numbers Check all Programs and write in the permits/registration numbers that will be affected by the updates submitted on this form. See the Core Data Form instructions for additional guidance.

<input type="checkbox"/> Dam Safety	<input type="checkbox"/> Districts	<input type="checkbox"/> Edwards Aquifer	<input type="checkbox"/> Emissions Inventory Air	<input type="checkbox"/> Industrial Hazardous Waste
<input type="checkbox"/> Municipal Solid Waste	<input type="checkbox"/> New Source Review Air	<input type="checkbox"/> OSSF	<input type="checkbox"/> Petroleum Storage Tank	<input type="checkbox"/> PWS
<input type="checkbox"/> Sludge	<input type="checkbox"/> Storm Water	<input type="checkbox"/> Title V Air	<input type="checkbox"/> Tires	<input type="checkbox"/> Used Oil
<input type="checkbox"/> Voluntary Cleanup	<input type="checkbox"/> Wastewater	<input type="checkbox"/> Wastewater Agriculture	<input type="checkbox"/> Water Rights	<input type="checkbox"/> Other:

SECTION IV: Preparer Information

40. Name:	Charles R. Marsh P.E.	41. Title:	Project Director
42. Telephone Number	43. Ext./Code	44. Fax Number	45. E-Mail Address
(817) 735-9770		(817) 735-9775	cmarsh@wcgrp.com

SECTION V: Authorized Signature

46. By my signature below, I certify, to the best of my knowledge, that the information provided in this form is true and complete, and that I have signature authority to submit this form on behalf of the entity specified in Section II, Field 6 and/or as required for the updates to the ID numbers identified in field 39.

Company:	Waste Connections Lone Star, Inc.	Job Title:	Regional Engineering Manager
Name (In Print):	Brett O'Connor	Phone:	(620) 778-2039
Signature:		Date:	7-18-24



Texas Commission on Environmental Quality

Part I Application Form for New Permit, Permit Amendment, or Registration for a Municipal Solid Waste Facility

Application Tracking Information

Facility Name: San Antonio Transfer Station

Permittee or Registrant Name: Waste Connections Lone Star, Inc.

MSW Authorization Number: MSW-2420

Initial Submission Date: 01/19/2024

Revision Date: 07/12/2024

Instructions for completing this Part I Application Form are provided in [TCEQ 00650-instr](#)¹. Include a [Core Data Form \(TCEQ 10400\)](#)² with the application for the facility owner, and another Core Data Form for the operator if different from the owner. If you have questions, contact the Municipal Solid Waste Permits Section by email to mswper@tceq.texas.gov, or by phone at 512-239-2335.

Application Data

1. Submission Type

Initial Submission Notice of Deficiency (NOD) Response

2. Authorization Type

Permit Registration

3. Application Type

New Permit

Permit Major Amendment Permit Limited Scope Major Amendment

New Registration

¹ www.tceq.texas.gov/downloads/permitting/waste-permits/msw/forms/00650-instr.pdf

² www.tceq.texas.gov/goto/coredata

4. Application Fee

Amount

- \$2,050—New Landfill Permits, and Landfill Permit Major Amendments Described in 30 TAC [305.62\(j\)\(1\)](#)
- \$150—Other Permits, Landfill Limited Scope Major Amendments, Permit Amendments for Storage and Processing Facilities, and Registrations

Payment Method

- Check
- Online through ePay portal www3.tceq.texas.gov/epay/

If paid online, enter ePay Trace Number: 582EA000587849

5. Application URL

For applications other than those for arid exempt landfills, provide the URL address of a publicly accessible internet web site where the application and all revisions to the application will be posted.

ftweaverboos.com

6. Party Responsible for Publishing Notice

Indicate who will be responsible for publishing notice:

- Applicant Agent in Service Consultant

Contact Name: Charles R, Marsh

Title: Project Director

Email Address: cmarsh@wcgrp.com

7. Alternative Language Notice

Use the Alternative Language Checklist on Public Notice Verification Form TCEQ-20244-Waste-NORI, TCEQ-20244-Waste-NAPD, or TCEQ-20244-Waste-NAORPM available at www.tceq.texas.gov/permitting/waste_permits/msw_permits/msw_notice.html to determine if an alternative language notice is required.

Is an alternative language notice required for this application?

- Yes No

Indicate the alternative language: Spanish

8. Public Place for Copy of Application

Name of the Public Place: Schaefer Library
 Physical Address: 6322 US Hwy 87 E
 City: San Antonio County: Bexar State: TX Zip Code: 78222
 Phone Number: (210)-207-9300

9. Consolidated Permit Processing

Is this submittal part of a consolidated permit processing request, in accordance with 30 TAC Chapter 33?

Yes No

If "Yes", indicate the other TCEQ program authorizations requested:

10. Confidential Documents

Does the application contain confidential documents?

Yes No

If "Yes", reference the confidential documents in the application, but submit the confidential documents as an attachment in a separate binder marked "CONFIDENTIAL."

11. Permits and Construction Approvals

Mark the following table to indicate status of other permits or approvals.

Table 1. Permits and Construction Approvals.

Permit or Approval	Received	Pending	Not Applicable
Hazardous Waste Management Program under Texas Solid Waste Disposal Act			X
Underground Injection Control Program under Texas Injection Well Act			X
National Pollutant Discharge Elimination System Program under Clean Water Act; Waste Discharge Program under Texas Water Code, Chapter 26		X	
Prevention of Significant Deterioration Program under Federal Clean Air Act (FCAA); Nonattainment Program under the FCAA			X
National Emission Standards for Hazardous Air Pollutants Preconstruction Approval under the FCAA			X

Permit or Approval	Received	Pending	Not Applicable
Ocean Dumping Permits under Marine Protection Research and Sanctuaries Act			X
Dredge or Fill Permits under Clean Water Act			X
Licenses under the Texas Radiation Control Act			X
Other (describe):			
Other (describe):			

12. Facility General Information

Facility Name: San Antonio Transfer Station

Contact Name: Brett O'Connor Title: Region Engineering Manager

MSW Authorization Number (if existing): MSW-2420

Regulated Entity Reference Number: **RN** 111892352

Physical or Street Address (if available): 10244 FM 1346

City: San Antonio County: Bexar State: TX Zip Code: 78101

Phone Number: (620) 778-2039

Latitude (Degrees, Minutes Seconds): 29° 25' 12"

Longitude (Degrees, Minutes Seconds): 98° 17' 8"

Benchmark Elevation (above mean sea level): 645 feet

Description of facility location with respect to known or easily identifiable landmarks:
1.5 miles west of intersection on FM 1604 and FM 1346 on FM 1346.

Access routes from the nearest United States or state highway to the facility:

The site will be accessed from 1346, which is approximately 3.7 miles south of the intersection of Interstate 10 and FM 1604 and then 1.5 miles west of intersection of FM 1604 and FM 1346.

Coastal Management Program

Is the facility within the Coastal Management Program boundary?

Yes No

13. Facility Types

- Type I Type IV Type V
 Type IAE Type IVAE Type VI

14. Activities Conducted at the Facility

- Storage Processing Disposal

15. Facility Waste Management Units

Check the box for each type of waste management unit proposed.

- | | |
|---|---|
| <input type="checkbox"/> Landfill Unit(s) | <input checked="" type="checkbox"/> Container(s) |
| <input type="checkbox"/> Incinerator(s) | <input checked="" type="checkbox"/> Roll-off Boxes |
| <input type="checkbox"/> Class 1 Landfill Unit(s) | <input type="checkbox"/> Surface Impoundment |
| <input type="checkbox"/> Process Tank(s) | <input type="checkbox"/> Autoclave(s) |
| <input checked="" type="checkbox"/> Storage Tank(s) | <input type="checkbox"/> Refrigeration Unit(s) |
| <input checked="" type="checkbox"/> Tipping Floor | <input type="checkbox"/> Mobile Processing Unit(s) |
| <input checked="" type="checkbox"/> Storage Area | <input type="checkbox"/> Compost Pile(s) or Vessel(s) |
| <input type="checkbox"/> Other (specify): | |

16. Description of Proposed Facility or Changes to Existing Facility

Provide a brief description of the proposed activities if application is for a new facility, or the proposed changes to an existing facility or permit conditions if the application is for an amendment.

The San Antonio Transfer Station is a proposed new facility, with a proposed MSW transfer capacity of 125 tons per day. MSW transfer operations will occur completely within the transfer station structure. The facility will include a scale house, scales, the TS building and associated infrastructure.

17. Facility Contact Information

Site Operator (Permittee or Registrant)

Name: Waste Connections Lone Star, Inc.

Customer Reference Number: **CN** 600321871

Contact Name: Brett O'Connor Title: Region Engineering Manager

Mailing Address: 3 Hughes Landing, 8th Floor

City: The Woodlands County: Montgomery State: TX Zip Code: 77381

Phone Number: (620) 778-2039

Email Address: bretto@wasteconnections.com

Texas Secretary of State (SOS) Filing Number: 0131598000

Operator (if different from Site Operator)

Name: _____

Customer Reference Number: **CN** _____

Contact Name: _____ Title: _____

Mailing Address: _____

City: _____ County: _____ State: _____ Zip Code: _____

Phone Number: _____

Email Address: _____

Texas Secretary of State (SOS) Filing Number: _____

Consultant (if applicable)

Firm Name: Weaver Consultants Group, LLC

Consultant Name: Charles R. Marsh

Texas Board of Professional Engineers Firm Registration Number: F-3727

Contact Name: Charles R. Marsh Title: Project Director

Mailing Address: 6420 Southwest Boulevard, Suite 206

City: Fort Worth County: Tarrant State: TX Zip Code: 76109

Phone Number: 817-735-9770

Email Address: cmarsh@wcgrp.com

Agent in Service (required for out-of-state applicants)

Name: _____

Mailing Address: _____

City: _____ County: _____ State: TX Zip Code: _____

Phone Number: _____

Email Address: _____

18. Facility Supervisor License

Indicate the level of Municipal Solid Waste Facility Supervisor license, as defined in 30 TAC Chapter 30, Occupational Licenses and Registrations, Subchapter F that the individual who supervises or manages the operations will obtain prior to commencing operations.

Class A Supervisor License Class B Supervisor License

19. Ownership Status of the Facility

Business Type

- | | |
|---|---|
| <input checked="" type="checkbox"/> Corporation | <input type="checkbox"/> County Government |
| <input type="checkbox"/> Individual | <input type="checkbox"/> State Government |
| <input type="checkbox"/> Sole Proprietorship | <input type="checkbox"/> Federal Government |
| <input type="checkbox"/> General Partnership | <input type="checkbox"/> Other Government |
| <input type="checkbox"/> Limited Partnership | <input type="checkbox"/> Military |
| <input type="checkbox"/> City Government | <input type="checkbox"/> Other (specify): _____ |

Facility Owner

Does the Site Operator (Permittee or Registrant) own all the facility units and all the facility property?

Yes No

If "No", provide the following information for other owners.

Owner Name: _____

Mailing Address: _____

City: _____ County: _____ State: TX Zip Code: _____

Phone Number: _____

Email Address: _____

20. Other Government Entities Information

Texas Department of Transportation

District: San Antonio

District Engineer's Name: Orlando Gallegos, P.E.

Mailing Address: 4615 NW Loop 410

City: San Antonio County: Bexar State: TX Zip Code: 78229

Phone Number: 210-615-1110

Email Address: orlando.gallegos@txdot.gov

Local Government Authority Responsible for Road Maintenance (if applicable)

Government or Agency Name: City of San Antonio
Contact Person's Name: Razi Hosseini
Mailing Address: 100 W. Houston St. 15th Floor
City: San Antonio County: Bexar State: TX Zip Code: 78205
Phone Number: 210-207-80202
Email Address: razi.hosseini@sanantonio.gov

City Mayor Information

City Mayor's Name: Ron Nirenberg
Mailing Address: 100 Military Plaza
City: San Antonio County: Bexar State: TX Zip Code: 78205
Phone Number: 210-207-7107
Email Address: ron.nirenberg@sanantonio.gov

City Health Authority

Authority Name: Metropolitan Health Department
Contact Person's Name: Junda Woo, MD, MPH
Mailing Address: 111 Soledad, Suite. 1000
City: San Antonio County: Bexar State: TX Zip Code: 78205
Phone Number: 210-207-8999
Email Address: junda.woo@sanantonio.gov

County Judge Information

County Judge's Name: Peter Sakal
Mailing Address: 101 W. Nueva, 10th Floor
City: San Antonio County: Bexar State: TX Zip Code: 78205
Phone Number: 210-335-1326
Email Address: countyjudge@bexar.org

County Health Authority

Agency Name: San Antonio Metropolitan Health Departm
Contact Person's Name: Junda Woo, MD, MPH
Mailing Address: 111 Soledad, Suite. 1000
City: San Antonio County: Bexar State: TX Zip Code: 78205
Phone Number: 210-207-8999
Email Address: junda.woo@sanantonio.gov

State Representative Information

District Number: 119
 State Representative's Name: Honorable Elizabeth Campos
 District Office Mailing Address: 3124 Sidney Brooks, Suite A
 City: San Antonio County: Bexar State: TX Zip Code: 78235
 Phone Number: 210-806-0899
 Email Address: elizabeth.campos@house.texas.gov

State Senator Information

District Number: 19
 State Senator's Name: Honorable Roland Gutierrez
 District Office Mailing Address: 1313 SE Military Dr., Suite 207
 City: San Antonio County: Bexar State: TX Zip Code: 78214
 Phone Number: 210-532-2302
 Email Address: ronald.gutierrez@senate.texas.gov

Council of Governments (COG)

COG Name: Alamo Area Council Governments
 COG Representative's Name: Shauna Duff
 COG Representative's Title: Resources Recovery Assistant
 Mailing Address: 2700 NE Loop 410, Suite 101
 City: San Antonio County: Bexar State: TX Zip Code: 78217
 Phone Number: 210-837.7599
 Email Address: sduff@aacog.com

River Basin Authority

Authority Name: San Antonio River Authority
 Contact Person's Name: Deb B. Prost
 Watershed Sub-Basin Name: Cibolo Creek Watershed
 Mailing Address: 100 E. Guenther Street
 City: San Antonio County: Bexar State: TX Zip Code: 78204
 Phone Number: 210-227-1373
 Email Address: dprost@sariverauthority.org

U.S. Army Corps of Engineers District

Indicate the U.S. Army Corps of Engineers district in which the facility is located:

- Albuquerque, NM Galveston, TX
 Ft. Worth, TX Tulsa, OK

Local Government Jurisdiction

Within City Limits of: Not Applicable

Within Extraterritorial Jurisdiction of: City of San Antonio

Is the facility located in an area in which the governing body of the municipality or county has prohibited the storage, processing, or disposal of municipal or industrial solid waste?

Yes No

If "Yes", provide a copy of the ordinance or order as an attachment.

Signature Page

Site Operator or Authorized Signatory

I certify under penalty of law that this document and all attachments were prepared under my direction or supervision in accordance with a system designed to assure that qualified personnel properly gather and evaluate the information submitted. Based on my inquiry of the person or persons who manage the system, or those persons directly responsible for gathering the information, the information submitted is, to the best of my knowledge and belief, true, accurate, and complete. I am aware there are significant penalties for submitting false information, including the possibility of fine and imprisonment for knowing violations.

Name: Brett O'Connor Title: Region Engineering Manager

Email Address: bretto@wasteconnections.com

Signature: [Handwritten Signature] Date: 7-18-24

Operator or Principal Executive Officer Designation of Authorized Signatory

To be completed by the operator if the application is signed by an authorized representative for the operator.

I hereby designate _____ as my representative and hereby authorize said representative to sign any application, submit additional information as may be requested by the Commission; and/or appear for me at any hearing or before the Texas Commission on Environmental Quality in conjunction with this request for a Texas Water Code or Texas Solid Waste Disposal Act permit. I further understand that I am responsible for the contents of this application, for oral statements given by my authorized representative in support of the application, and for compliance with the terms and conditions of any permit which might be issued based upon this application.

Operator or Principal Executive Officer Name: _____

Email Address: _____

Signature: _____ Date: _____

Notary

SUBSCRIBED AND SWORN to before me by the said Brett O'Connor

On this 18th day of July, 2024

My commission expires on the 31st day of March, 2025

[Handwritten Signature]

Notary Public in and for

Tarrant County, Texas

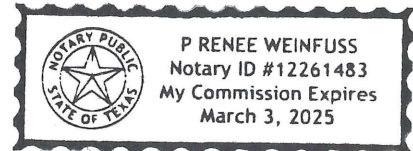

Note: Application Must Bear Signature & Seal of Notary Public

Part I Attachments

Refer to instruction document 00650-instr for professional engineer seal requirements.

Attachments Table 1. Required attachments.

Required Attachments	Attachment Number
Supplementary Technical Report	Parts I/II Section 2
Property Legal Description	Parts I/II Section 13
Property Metes and Bounds Description	Parts I/II Section 13
Facility Legal Description	Parts I/II Section 13
Facility Metes and Bounds Description	Parts I/II Section 13
Metes and Bounds Drawings	Parts I/II Section 13
On-Site Easements Drawing	Parts I/II Section 13
Land Ownership Map	Parts I/II Section 5
Landowners List	Provided in CD
Mailing Labels (printed and electronic)	Provided in CD
Texas Department of Transportation (TxDOT) County Map	Parts I/II Section 4
General Location Map	Parts I/II Section 4
General Topographic Map	Parts I/II Section 4
Verification of Legal Status	Parts I/II Section 15
Property Owner Affidavit	Parts I/II Section 14
Evidence of Competency	Parts I/II Section 16

Attachments Table 2. Additional attachments as applicable.

Additional Attachments as Applicable (select all that apply and add others as needed)	Attachment Number
<input checked="" type="checkbox"/> TCEQ Core Data Form(s)	
<input checked="" type="checkbox"/> Signatory Authority Delegation	
<input checked="" type="checkbox"/> Fee Payment Receipt	
<input type="checkbox"/> Confidential Documents	
<input type="checkbox"/> Waste Storage, Processing and Disposal Ordinances	
<input type="checkbox"/> Final Plat Record of Property	

Additional Attachments as Applicable (select all that apply and add others as needed)	Attachment Number
<input type="checkbox"/> Certificate of Fact (Certificate of Incorporation)	
<input type="checkbox"/> Assumed Name Certificate	
Other (describe):	
Other (describe):	
Other (describe):	



Texas Commission on Environmental Quality

Public Involvement Plan Form for Permit and Registration Applications

The Public Involvement Plan is intended to provide applicants and the agency with information about how public outreach will be accomplished for certain types of applications in certain geographical areas of the state. It is intended to apply to new activities; major changes at existing plants, facilities, and processes; and to activities which are likely to have significant interest from the public. This preliminary screening is designed to identify applications that will benefit from an initial assessment of the need for enhanced public outreach.

All applicable sections of this form should be completed and submitted with the permit or registration application. For instructions on how to complete this form, see TCEQ-20960-inst.

Section 1. Preliminary Screening

- New Permit or Registration Application
 New Activity - modification, registration, amendment, facility, etc. (see instructions)

If neither of the above boxes are checked, completion of the form is not required and does not need to be submitted.

Section 2. Secondary Screening

- Requires public notice,
 Considered to have significant public interest, **and**
 Located within any of the following geographical locations:
- Austin
 - Dallas
 - Fort Worth
 - Houston
 - San Antonio
 - West Texas
 - Texas Panhandle
 - Along the Texas/Mexico Border
 - Other geographical locations should be decided on a case-by-case basis

**If all the above boxes are not checked, a Public Involvement Plan is not necessary.
Stop after Section 2 and submit the form.**

- Public Involvement Plan not applicable to this application. Provide **brief** explanation.

Section 3. Application Information

Type of Application (check all that apply):

Air Initial Federal Amendment Standard Permit Title V

Waste Municipal Solid Waste Industrial and Hazardous Waste Scrap Tire
 Radioactive Material Licensing Underground Injection Control

Water Quality

- Texas Pollutant Discharge Elimination System (TPDES)
 - Texas Land Application Permit (TLAP)
 - State Only Concentrated Animal Feeding Operation (CAFO)
 - Water Treatment Plant Residuals Disposal Permit
- Class B Biosolids Land Application Permit
- Domestic Septage Land Application Registration

Water Rights New Permit

- New Appropriation of Water
- New or existing reservoir

Amendment to an Existing Water Right

- Add a New Appropriation of Water
- Add a New or Existing Reservoir
- Major Amendment that could affect other water rights or the environment

Section 4. Plain Language Summary

Provide a brief description of planned activities.

The proposed project is a Type V Municipal Solid Waste Transfer Station (TS) that will collect waste from collection vehicles and consolidate that waste into larger vehicles to be sent to a permitted landfill. The TS facility will include a 150' x 130' building, paved roads and parking, fencing, utilities, and stormwater management facilities.

Section 5. Community and Demographic Information

Community information can be found using EPA's EJ Screen, U.S. Census Bureau information, or generally available demographic tools.

Information gathered in this section can assist with the determination of whether alternative language notice is necessary. Please provide the following information.

(City)

The TS is not located within any incorporated city limits, and is within the ETJ of San Antonio.

(County)

Bexar

(Census Tract)

Please indicate which of these three is the level used for gathering the following information.

City

County

Census Tract

(a) Percent of people over 25 years of age who at least graduated from high school

According to the U.S. Census Bureau, the percentage of people over 25 years of age who at least graduated from high school in Bexar County, Texas was 85.9% from 2018 to 2022

(b) Per capita income for population near the specified location

According to the U.S. Census Bureau, The per capita income for the population in Bexar County, Texas was \$33,963 from 2018 to 2022.

(c) Percent of minority population and percent of population by race within the specified location

According to the U.S. Census Bureau, White: 25.9%, Hispanic or Latino: 61.3%, Black or African American: 9.1%, American Indian and Alaska Native: 1.3%, Asian: 3.5%, Native Hawaiian and other Pacific Islander: 0.2%, Two or more races: 2.7%

(d) Percent of Linguistically Isolated Households by language within the specified location

Spanish: 34.0%, Other Indo-European languages: 1.5%, Asian and Pacific Island languages: 1.8%, Other languages: 0.6%

(e) Languages commonly spoken in area by percentage

According to the U.S. Census Bureau, English: 62.0%, Spanish: 34.0%, Other Indo-European languages: 1.5%, Asian and Pacific Island languages: 1.8%, Other languages: 0.6%

(f) Community and/or Stakeholder Groups

SA Digital Connects, Bexar County Judge's Community Engagement, Future Ready Bexar County, Bexar Cares.

(g) Historic public interest or involvement

None at this site.

Section 6. Planned Public Outreach Activities

(a) Is this application subject to the public participation requirements of Title 30 Texas Administrative Code (30 TAC) Chapter 39?

Yes No

(b) If yes, do you intend at this time to provide public outreach other than what is required by rule?

Yes No

If Yes, please describe.

If you answered "yes" that this application is subject to 30 TAC Chapter 39, answering the remaining questions in Section 6 is not required.

(c) Will you provide notice of this application in alternative languages?

Yes No

Please refer to Section 5. If more than 5% of the population potentially affected by your application is Limited English Proficient, then you are required to provide notice in the alternative language.

If yes, how will you provide notice in alternative languages?

- Publish in alternative language newspaper
 Posted on Commissioner's Integrated Database Website
 Mailed by TCEQ's Office of the Chief Clerk
 Other (specify)

(d) Is there an opportunity for some type of public meeting, including after notice?

Yes No

(e) If a public meeting is held, will a translator be provided if requested?

Yes No

(f) Hard copies of the application will be available at the following (check all that apply):

- TCEQ Regional Office TCEQ Central Office
 Public Place (specify) Schaefer Library

Section 7. Voluntary Submittal

For applicants voluntarily providing this Public Involvement Plan, who are not subject to formal public participation requirements.

Will you provide notice of this application, including notice in alternative languages?

Yes No

What types of notice will be provided?

- Publish in alternative language newspaper
 Posted on Commissioner's Integrated Database Website
 Mailed by TCEQ's Office of the Chief Clerk
 Other (specify)



Texas Commission on Environmental Quality Plain Language Summary of Municipal Solid Waste Permit or Permit Amendment Application

Applicants are required by public notice rules in Title 30 Texas Administrative Code, Chapter 39, Section [39.405\(k\)](#)¹ to provide this summary of an application.

A. Purpose of the Proposed Facility

Transferring solid waste from collection vehicles to larger vehicles with more capacity for transfer to a landfill.

B. Information About the Applicant

Name: Waste Connections Lone Star, Inc.

Applicant Type: Type V

Facility Name: San Antonio Transfer Station

Permit Application Number: 2420

Customer Number (CN): CN600321871

Regulated Entity Reference Number (RN): RN111892352

C. Location of the Proposed Facility

Facility Address (or description of site location if no address):

10244 FM 1346, San Antonio, TX 78101

Link to Map of Facility Location ([TCEQ Location Mapper](#)²): <https://arcg.is/HWG9f>

D. Information about Facility Operation

What types of waste would be received?

Household waste, yard waste, commercial waste, certain types of industrial waste(nonhazardous), special waste, and construction-demolition waste.

What geographical area would the wastes come from?

Service Area consists of the City of San Antonio residents, businesses and surrounding rural areas.

¹ www.tceq.texas.gov/goto/view-30tac

² www.tceq.texas.gov/gis/hb-610-viewer

What days and hours would the facility operate?

Waste acceptance hours and days are between the hours of 3:00 a.m. and 7:00 p.m., Monday through Saturday.

Heavy equipment operation, transfer trailer loading, and transportation of materials off the site may occur between 1:00 a.m. and 9:00 p.m., Monday through Saturday.

At what rate would wastes be accepted?

2,500 tons per day.

How would wastes be managed?

The TS facility will be a steel-framed structure with a metal roof and walls covering an open concrete tipping floor. The north and south sides will be open for hauling vehicle access. Waste from hauling vehicles is unloaded onto the tipping floor then loaded into transfer trailers and hauled to a permitted landfill. The tipping floor will have an area of approximately 19,500 square feet (150 feet by 130 feet).

E. Pollution Control Methods

What methods would the facility use for containing wastes and odors, and monitoring for releases?

All waste processing and storage will occur within the building. Storage of waste will not exceed 72 hours and will average 24 hours. To control odors, routine tipping, sorting and transfer operations will be confined within the building. The following measures will be employed to assist in air pollution/odor control:

- Buffer zones onsite;
- Odor mister system as necessary;
- Covering transfer trucks;
- No liquid waste or sludges accepted;
- Special procedures for odorous loads as described in Part III 2.2.3;
- Cleaning all working surfaces that come in contact with waste at least weekly as described in Part IV 7:11.

What methods would the facility use or require for preventing litter or spills, and for cleanup of litter and spills?

Policing of litter and fugitive debris at the facility entrance area will be performed as part of a scheduled routine. Any litter scattered throughout the site, including along fences and access roads, and at the gate will be collected at least daily on the days the facility is in operation. Any spills will be contained within the building, analyzed as appropriate, and properly handled.



Comisión de Calidad Ambiental de Texas

Resumen en lenguaje sencillo de la solicitud de permiso municipal de residuos sólidos o de modificación del permiso

Los solicitantes están obligados por las normas de notificación pública del Título 30 del Código Administrativo de Texas, Capítulo 39, Sección [39.405\(k\)](#)¹ a proporcionar este resumen de una solicitud.

A. Objetivo de la instalación propuesta

Transladar residuo sólido de los vehículos de colección de residuo a vehículos mas grandes, con mayor capacidad para trasladar el residuo sólido a el vertedero.

B. Información sobre el solicitante

Nombre: Waste Connections Lone Star, Inc.

Tipo de solicitante: Type V

Nombre de la instalación: San Antonio Transfer Station

Número de solicitud de permiso: 2420

Número de cliente (CN): CN600327871

Número de referencia de la entidad regulada (RN): RN111892352

C. Ubicación de la instalación propuesta

Dirección del establecimiento (o descripción de la ubicación del sitio si no hay dirección):

10244 FM 1346, San Antonio, TX 78101

Enlace al mapa de ubicación de las instalaciones en [TCEQ Location Mapper](#)²:

<https://arcg.is/HWG9f>

D. Información sobre el funcionamiento de las instalaciones

¿Qué tipos de residuos se recibirían?

Desechos domésticos, desechos de jardín, residuos comerciales, ciertos residuos industriales (No peligrosos), residuos especiales, y residuos de construcción y demolición.

¿De qué zona geográfica procederían los residuos?

El area de servicio consiste en los residentes de la ciudad de San Antonio, negocios, y pueblos rurales a los alrededores.

¹ www.tceq.texas.gov/goto/view-30tac

² www.tceq.texas.gov/gis/hb-610-viewer

¿Qué días y horas funcionará la instalación?

Las horas y días que se aceptaran residuos son de Lunes a Sabado de las 3:00 am a las 7:00 pm.

¿A qué ritmo se aceptarían los residuos?

2,500 toneladas por día.

¿Cómo se gestionarían los residuos?

La instalación de transferencia de residuos sera una estructura de acero con techo de metal y paredes cubriendo el muelle de descarga de concreto. Los lados norte y sur estaran abiertos para el acceso de los vehículos de carga. El residuo de los vehículos de carga seran descargados en el muelle de descarga y ahi seran cargados los camiones que llevaran los residuos a el vertedero. El muelle de descarga tendra una area de aproximadamente 19,500 pies cuadrados (150 pies por 130 pies)

E. Métodos de control de la contaminación

¿Qué métodos utilizará la instalación para contener los residuos y los olores, y para controlar las emisiones?

Todo el procesamiento y almacenamiento de los residuos ocurriran en el edificio. El almacenamiento de los residuos no superara las 72 horas y promediará las 24 horas. Para controlar los olores, el vertido de residuos y la operacion de clasificacion y transferencia seran confinadas dentro de el edificio. Las siguientes medidas seran tomadas para asistir en el control de olores y contaminacion de aire.

- Zona de amortiguamiento en el sitio; Sistema de nebulazion de olores cuando sea necesario.
- Cubrir los camiones de traslado de residuos; No se aceptaran residuos liquidos o viscosos.
- Se seguira un procedimiento especial para cargas olorosas como es descrito en parte III 2.2.3.
- Limpiar todas las superficies en contacto con residuos por lo menos una vez por semana como es descrito en parte IV 7.11.

¿Qué métodos utilizaría o exigiría la instalación para evitar la basura o los derrames, y para la limpieza de la basura y los derrames?

Se realizara la vigilancia de basura y escombros fugitivos en el area de entrada de la instalación como parte de un proceso rutinario. Cualquier basura encontrada a lo largo de la instalación, incluyendo la cerca, carreteras de acceso y el portón sera collectada diariamente en los dias que la instalación este abierta para operar. Cualquier derrame sera contenido en el edificio, analizado apropiadamente y manejado adecuadamente.

**SAN ANTONIO TRANSFER STATION
BEXAR COUNTY, TEXAS
TCEQ PERMIT NO. MSW-2420**

TYPE V TRANSFER STATION PERMIT APPLICATION

PARTS I/II

GENERAL APPLICATION REQUIREMENTS

Prepared for
Waste Connections Lone Star, Inc.

January 2024
Revised May 2024
Revised July 2024

Revised September 2024

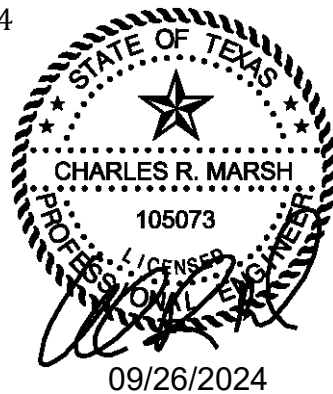

Prepared by
Weaver Consultants Group, LLC
TBPE Registration No. F-3727
6420 Southwest Boulevard, Suite 206
Fort Worth, Texas 76109
817-735-9770

WCG Project No. 0601-012-11-01

This document is issued for permitting purposes only.

CONTENTS

1	INTRODUCTION	I/II-1-1
2	SUPPLEMENTARY TECHNICAL REPORT	I/II-2-1
	2.1 Facility Description	I/II-2-1
	2.1.1 Waste Acceptance Plan	I/II-2-1
	2.1.2 Service Area and Population Equivalent	I/II-2-4
	2.1.3 Site Development Plan	I/II-2-5
	2.1.4 Site Operating Plan	I/II-2-5
	2.2 Texas Historical Commission Review	I/II-2-6
	2.3 Alamo Area Council of Governments	I/II-2-6
	2.4 Abandoned Oil and Water Wells	I/II-2-6
	2.4.1 Water Wells	I/II-2-6
	2.4.2 Oil and Gas Wells	I/II-2-6
	2.5 Internet Posting	I/II-2-7
	2.6 Other Permits/Authorizations	I/II-2-7
3	EXISTING CONDITIONS SUMMARY	I/II-3-1
4	MAPS	I/II-4-1
5	PROPERTY OWNERS LIST AND MAP	I/II-5-1
6	AERIAL PHOTOGRAPH	I/II-6-1
7	LAND USE	I/II-7-1
	7.1 Character of Surrounding Land and Land Use	I/II-7-1
	7.2 Location and Zoning	I/II-7-1
	7.3 Surrounding Land Use	I/II-7-1
	7.4 Growth Trends of the Nearest Community	I/II-7-1
	7.5 Proximity to Residences and Other Uses	I/II-7-2
	7.6 Land Use Conclusions	I/II-7-2
	7.7 Oil and Water Wells Within 500 Feet	I/II-7-2
8	TRANSPORTATION	I/II-8-1
	8.1 Traffic Information	I/II-8-1
	8.2 Airport Impact	I/II-8-1
9	GENERAL GEOLOGY AND SOILS STATEMENT	I/II-9-1
10	GROUNDWATER AND SURFACE WATER STATEMENT	I/II-10-1



CONTENTS (Continued)

10.1	Groundwater Statement	I/II-10-1
10.2	Surface Water Statement	I/II-10-1
11	FLOODPLAIN AND WETLANDS STATEMENT	I/II-11-1
11.1	Floodplain Statement	I/II-11-1
11.2	Wetlands Statement	I/II-11-1
	11.2.1 Regulatory Background	I/II-11-1
12	PROTECTION OF ENDANGERED SPECIES	I/II-12-1
13	LEGAL DESCRIPTION	I/II-13-1
14	PROPERTY OWNER AFFIDAVIT	I/II-14-1
15	LEGAL AUTHORITY	I/II-15-1
16	EVIDENCE OF COMPETENCY	I/II-16-1
16.1	Solid Waste Sites	I/II-16-1
16.2	San Antonio Transfer Station Key Personnel	I/II-16-1
16.3	Equipment	I/II-16-2
17	APPOINTMENTS	I/II-17-1
APPENDIX I/IIA DEMONSTRATION OF COORDINATION		
	<ul style="list-style-type: none">• Coordination with Texas Department of Transportation• Coordination with Texas Historical Commission• Coordination with Texas Parks and Wildlife Department• Coordination with Alamo Area Council of Governments	
APPENDIX I/IIB AREA WATER WELL INFORMATION		
APPENDIX I/IIC WETLANDS REPORT		
APPENDIX I/IID THREATENED AND ENDANGERED SPECIES REPORT		

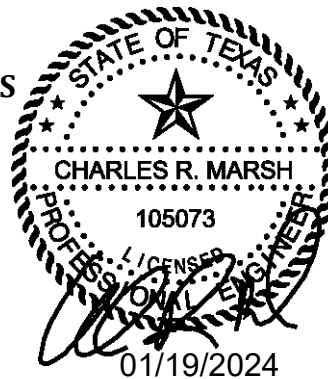

TABLES AND FIGURES

Tables	Page
2-1 Waste Acceptance Evaluation	I/II-2-5
5-1 Property Owners List	I/II-5-2
7-1 Growth Trends – Average Annual Growth Rate	I/II-7-2
12-1 Federally Protected Species Occurring in Dallas County, Texas	I/II-12-1
12-2 State Protected Species Occurring in Dallas County, Texas	I/II-12-2
16-1 Texas Solid Waste Management Facilities	I/II-16-3

Figures

I/II-3.1 Existing Conditions - Aerial
I/II-3.2 Existing Contour Map
I/II-4.1 Site Location Map
I/II-4.2 General Topographic Map
I/II-4.3 Structures and Inhabitable Buildings within 500 Feet
I/II-4.4 Facility Layout Map
I/II-5.1 Property Owners Map
I/II-6.1 Aerial Photograph
I/II-7.1 Land Use Map – Aerial
I/II-7.2 Land Use Map
I/II-7.3 Zoning Map – City of Dallas
I/II-7.4 Zoning Map – City of Balch Springs
I/II-7.5 Cities within 5 Miles – Aerial
I/II-8.1 Area Airports
I/II-11.1 FEMA Flood Insurance Rate Map (FIRM)



1 INTRODUCTION

The San Antonio Transfer Station (TS) is a proposed Type V municipal solid waste (MSW) processing facility to be located in Bexar County, Texas. The proposed facility address is 10244 FM 1346, Bexar County, Texas 78101. The San Antonio TS will be owned and operated by Waste Connections Lone Star, Inc, (WCLSI).

*Parts I/II
addresses
§330.59,
§330.61, and
§305.45.*

The San Antonio TS will provide an efficient means to transfer MSW that is generated in the City of San Antonio, Bexar County, and the surrounding areas to a Texas Commission on Environmental Quality (TCEQ) permitted landfill. The General Application Requirements section (Parts I and II) of this application for the San Antonio TS has been prepared consistent with the applicable TCEQ requirements set forth in Title 30 TAC §330.59 and §330.61. As it is allowed by Title 30 TAC §330.57(c)(2), Parts I and II of the application are combined under “General Application Requirements.” Section 2, Supplementary Technical Report, presents an overview of the project and a detailed facility description, as well as the types of waste that will be accepted at the facility. The remaining portions of the General Application Requirements section of the Permit application present information on specific existing conditions (i.e., land use, transportation, and various compliance requirements) related to the TS facility location and legal matters of the entities involved in the application process.

2 SUPPLEMENTARY TECHNICAL REPORT

2.1 Facility Description

The San Antonio TS is a proposed Type V MSW processing facility to be located in Bexar County at 10244 FM 1346, Bexar County, Texas 78101. The longitudinal and latitudinal geographic coordinates for the San Antonio TS are shown in Figure I/II-4.2.

The proposed San Antonio TS is located southeast of San Antonio in Bexar County, Texas. The proposed TS will provide WCLSI the ability to collect, process, load, and transport solid waste and recyclables more efficiently by allowing small solid waste collection vehicles to transfer the solid waste into larger transfer trailers before transport to a permitted MSW landfill.

The quantity and types of waste to be transferred at the San Antonio TS, as well as the site development and site operations, are discussed in the following subsections.

The TS area for waste collection vehicles will consist of a reinforced concrete tipping floor (where incoming waste will be deposited) that extends beneath the entire overhead roof structure. The tipping floor will be well-lit (via natural lighting and overhead lighting), and include an area where transfer trailers will park during loading from the tipping floor. Incoming loads will be directed to the tipping floor for transfer operations. Typically, MSW deposited on the tipping floor will be pushed by a front-end loader to a grapple loader (or similar materials handling equipment), which will load the MSW into a transfer trailer. The grapple loader may also be used to compact the waste or more evenly distribute the waste within the transfer trailer. The transfer trailer will haul the MSW to a permitted MSW landfill. Facility layout drawings are included in Part III, Appendix IIIA.

The transfer station includes a covered structure. Ventilation is provided in the structure by the two open (north and south) sides and ventilation openings on the east and west walls of the structure. No significant air pollution emissions are expected to result from the operation of the facility. Exterior walls and parking areas will be lit by down cast lighting fixtures to minimize impact on adjacent residential properties.

2.1.1 Waste Acceptance Plan

The classifications of municipal solid waste to be accepted at the San Antonio TS include household waste, yard waste, commercial waste, certain types of industrial

This appendix addresses § 305.45(a)(7), § 305.45(a)(8), § 330.57(i), § 330.59(b), § 330.61(b), § 330.61(l), § 330.61(o), and § 330.61(p).

waste (nonhazardous), special waste, and construction-demolition waste. Each classification of waste is defined in Title 30 TAC §330.3 and summarized below:

- **Household Waste:** Any municipal solid waste (including garbage, trash, and sanitary waste in septic tanks) derived from households (including single and multiple residences, hotels, motels, bunkhouses, ranger stations, crew quarters, campgrounds, picnic grounds, and day-use recreation areas); does not include brush as defined in Title 30 TAC §330.3 definition (64).
- **Yard Waste:** Leaves, grass clippings, yard and garden debris, and brush, including clean woody vegetative material not greater than six inches in diameter, that results from landscaping maintenance and land-clearing operations. The term does not include stumps, roots, or shrubs with intact root balls.
- **Commercial Solid Waste:** All types of municipal solid waste generated by stores, offices, restaurants, warehouses, and other nonmanufacturing activities, excluding residential and industrial wastes.
- **Industrial Waste (Nonhazardous):** Municipal solid waste resulting from or incidental to any process of industry or manufacturing, or mining or agricultural operations, classified as follows:
 - Class 2 Industrial Solid Waste – Any individual solid waste or combination of industrial solid wastes that are not described as Hazardous, Class 1, or Class 3, as defined in Title 30 TAC §335.506 (relating to Class 2 Waste Determination).
 - Class 3 Industrial Solid Waste – Inert and essentially insoluble industrial solid waste, usually including, but not limited to, materials such as rock, brick, glass, dirt, and certain plastics and rubber, etc., that are not readily decomposable as further defined in Title 30 TAC §335.507 (relating to Class 3 Waste Determination).
- **Construction-Demolition Waste:** Waste resulting from construction or demolition projects; includes all materials that are directly or indirectly the by-products of construction work or that result from demolition of buildings and other structures, including, but not limited to, paper, cartons, gypsum board, wood, excelsior, rubber, and plastics.
- **Special Waste:** Any solid waste or combination of solid wastes that because of its quantity, concentration, physical or chemical characteristics, or biological properties requires special handling and disposal to protect the human health or the environment. Special wastes that may be accepted at this facility include:
 - slaughterhouse waste;
 - dead animals that are incidental to routine collection of municipal solid waste and that can be systematically processed along with other municipal solid waste;

- drugs, contaminated foods, or contaminated beverages other than those contained in normal household waste on a case by case basis;
- empty containers which have been used for pesticides, herbicides, fungicides or rodenticides, provided the containers have been triple rinsed, crushed, or rendered unusable upon receipt at the gate;
- incidental amounts of non-regulated asbestos-containing materials (NRACM) (an incidental amount is defined as the maximum of 10 percent of the waste received on an annual basis by scale weight);
- waste from oil, gas, and geothermal activities subject to regulation by the Railroad Commission of Texas when those wastes are to be processed, treated, or disposed of at a municipal solid waste management facility;
- waste generated outside the boundaries of Texas that contains any industrial waste (excluding Class 1 nonhazardous industrial waste): any waste associated with oil, gas, and geothermal exploration, production, or development activities; or any material that is listed above; and
- other waste than as described above and approved for acceptance by the Executive Director.

The procedures in the Waste Acceptance Plan included in Appendix IVA will be followed for special waste acceptance.

- **Prohibited Waste:** Consistent with Title 30 TAC §330.15(e), the facility will not accept the following:
 - Regulated hazardous waste
 - PCBs
 - Liquid Wastes
 - Certain special wastes, including:
 - o hazardous waste from conditionally exempt small-quantity generators that may be exempt from full controls under Chapter 335, Subchapter N of this title (relating to Household Materials Which Could Be Classified as Hazardous Wastes);
 - o Class 1 industrial nonhazardous waste;
 - o untreated medical waste;
 - o municipal wastewater treatment plant sludges, other types of domestic sewage treatment plant sludges, and water-supply treatment plant sludges;
 - o septic tank pumpings;
 - o grease and grit trap wastes;

- wastes from commercial or industrial wastewater treatment plants, air pollution control facilities, and tanks, drums, or containers used for shipping or storing any material that has been listed as a hazardous constituent in 40 CFR, Part 261, Appendix VIII but has not been listed as a commercial chemical product in 40 CFR, Section 261.33(e) or (f);
- incinerator ash;
- soil contaminated by petroleum products, crude oils, or chemicals in concentrations of greater than 1,500 milligrams per kilogram total petroleum hydrocarbons; or contaminated by constituents of concern that exceed the concentrations listed in Table 1 of §335.521(a)(1);
- used oil;
- lead acid storage batteries; and
- used-oil filters from internal combustion engines.

2.1.2 Service Area and Population Equivalent

The proposed San Antonio TS will provide waste disposal services for the City of San Antonio, Bexar County, and the surrounding areas. As discussed in Part III – Site Development Plan, the facility will have a capacity of 2,500 tons per day of MSW.

Waste will be transferred on a daily basis to a TCEQ permitted MSW landfill. The estimated maximum annual waste acceptance rate for the facility for five years is shown in Table 2-2.

**Table 2-1
5-Year Waste Acceptance Evaluation**

Year	Waste Acceptance ¹ (tons/yr)	Daily Waste Acceptance (tons/day)
2023	845,000	2,500
2024	845,000	2,500
2025	845,000	2,500
2026	845,000	2,500
2027	845,000	2,500
2028	845,000	2,500

¹ Based on 6.5 days per week acceptance.

The TS has been designed to provide for the safe and efficient transfer of waste, with additional tipping floor provided for staging and storage of waste .

As shown below, the average population equivalent using the above projected waste acceptance rate is 1,000,000 persons. As the transfer station service area conditions

change, adjustments to the service area population may occur. The population equivalent of the areas that are served by the TS are calculated as follows (for 2023):

$$\frac{(2,500 \text{ tons/day})(2,000 \text{ lbs/ton})}{(5 \text{ lbs/persons/day})} = 1,000,000 \text{ persons}$$

The maximum amount of waste that will be stored at the facility is 2,500 tons. If market conditions change and the facility stores more than 2,500 tons of waste overnight, a TCEQ authorization will be obtained to meet the provisions of Title 30 TAC §330.991(a)(2)(B). The maximum length of time material will remain onsite is 48 hours, except holidays and weekends, as discussed in Section 8.10 of Part IV – Site Operating Plan (SOP). During holidays and/or weekends, waste may be temporarily stored at the facility not to exceed a time period of 72 hours.

2.1.3 Site Development Plan

The site plans included within this application set forth the overall design and operating characteristics of the proposed TS. Drawings showing the TS layout are presented in Appendix IIIA of Part III – Site Development Plan (SDP). A summary of the development is provided below.

- The TS facility will be a steel-framed structure with a metal roof and walls covering an open concrete floor. Ventilation openings will be located on the east and west walls. The north and south sides will be open for hauling vehicle access. Transfer trailers enter the facility from the north. The tipping floor will have an area of approximately 20,000 square feet (150 feet by 130 feet).
- The scales will be positioned next to a proposed scalehouse with windows to allow for communication and exchange of paperwork.
- A minimum 2,000-gallon contaminated water holding tank will be located on the south side of the TS structure. Contaminated water and wash water from the tipping floor will drain to the holding tank prior to being pumped out and transported to a permitted wastewater treatment facility.

2.1.4 Site Operating Plan

The SOP for the San Antonio TS is presented in Part IV of this application. The site will be operated by appropriately trained personnel. The SOP describes the equipment, personnel, and safety procedures required to operate the site in accordance with TCEQ regulations.

WCLSI, the general public, and other commercial waste transportation companies may utilize this facility for the receipt and processing of waste between the hours of

5:00 a.m. and 7:00 p.m., Monday through Friday, and between 7:00 a.m. and 12:00 p.m. on Saturday. Waste receipt hours for the public will be posted on the entrance sign and will be within the hours listed above.

In addition to the waste acceptance hours above, heavy equipment operation, transfer trailer loading, and transportation of materials off the site may occur between 5:00 a.m. and 7:00 p.m. Monday through Friday, and between 7:00 a.m. and 4:00 p.m. on Saturday. Other non-waste management activities, including administrative and maintenance activities, do not require specific approval and may occur 24 hours per day, 7 days per week.

2.2 Texas Historical Commission Review

A Texas Historical Commission coordination letter is included in Appendix I/IIA. The Historical Commission concluded that no historic properties will be affected by the proposed TS development.

2.3 Alamo Area Council of Governments

The proposed San Antonio TS is consistent with the Alamo Areas Council of Governments (AACOG) Regional Solid Waste Plan

Parts I/II of this application was submitted to the AACOG in February 2024. A letter documenting that Parts I/II was submitted to the AACOG is included in Appendix I/IIA. Also included is the April 23, 2024 email from the AACOG stating that, upon review, the AACOG found the proposed transfer station to be consistent with the goals of their Regional Solid Waste Management Plan.

2.4 Abandoned Oil and Water Wells

2.4.1 Water Wells

A water well search was conducted by ERIS, for an area that included the TS property boundary area and the area within 0.5 miles of the site. A copy of the ERIS report is included as Appendix I/IIB. As shown on Figure I/II-4.2, there are no water wells located within 500 feet of the property boundary. According to the ERIS search, the nearest water well is over 7,000 feet northeast of the site.

If in the future any water well is discovered, WCLSI will, within 30 days of discovery, provide written certification to the TCEQ that all such wells have been capped, plugged, and closed in accordance with all applicable rules and regulations of the Commission or other state agency.

2.4.2 Oil and Gas Wells

An oil and gas well search was conducted by ERIS for the area within 0.5 miles of the property boundary. The search revealed that there were no producing well

locations or plugged wells located within 500 feet of the property, and the nearest oil/gas well is located over 1,300 feet west of the site.

2.5 Internet Posting

In accordance with Title 30 TAC §330.57(i), a complete copy of this application will be posted to the Internet at the following publicly accessible website: <http://www.ftwweaverboos.com>. All future revisions or supplements to this application will also be posted at the same location. This internet posting is for informational purposes only. The TCEQ web site will also contain information of the filing of this application along with a link to the above-mentioned web address.

2.6 Other Permits/Authorizations

In accordance with Title 30 TAC §305.45(a)(7), the related permits and authorizations for the facility are summarized in the Part I Form (TCEQ-0650 Form).

3 EXISTING CONDITIONS SUMMARY

The existing conditions and the existing contours of the site are shown on Figure I/II-3.1. The Property is comprised of a rectangular-shaped parcel that encompasses approximately 7.51-acres, where 1.5-acres are currently used for residential and commercial purposes and 6-acres are generally undeveloped land. The surrounding area consists of residential, commercial, and undeveloped land. The Property is bounded to the north by FM 1346 and beyond that is undeveloped property, to the west by commercial property, to the south by range/native pasture, and to the east by residential and undeveloped properties.

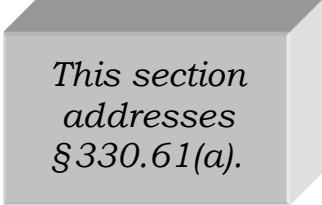

*This section
addresses
§330.61(a).*

4 MAPS

A site location map and general topographic map are presented on Figures I/II-4.1 and I/II-4.2. In accordance with Title 30 TAC §330.61(c)(3), structures and inhabitable buildings located within 500 feet, as well as the nearest residences, are shown on Figure I/II-4.3.

This section addresses § 330.59(c), § 330.61(c), § 330.61(e), § 305.45(a)(6)(A), and § 305.45(a)(6)(C).

Figure I/II-4.1 and Figure I/II-4.2 show surface water bodies in accordance with Title 30 TAC §330.59(c)(1) and §305.45(a)(6)(A). Gas wells within a mile of the permit boundary are shown on Figure I/II-4.2 in accordance with Title 30 TAC §330.59(c)(1) and §330.45(a)(6)(A). As noted on Figure I/II-4.2, no springs or water wells were found within 1 mile of the site.

Figure I/II-4.4 is a Facility Layout Map that includes the outline of the processing building, onsite roads, scalehouse and scales, and traffic patterns.

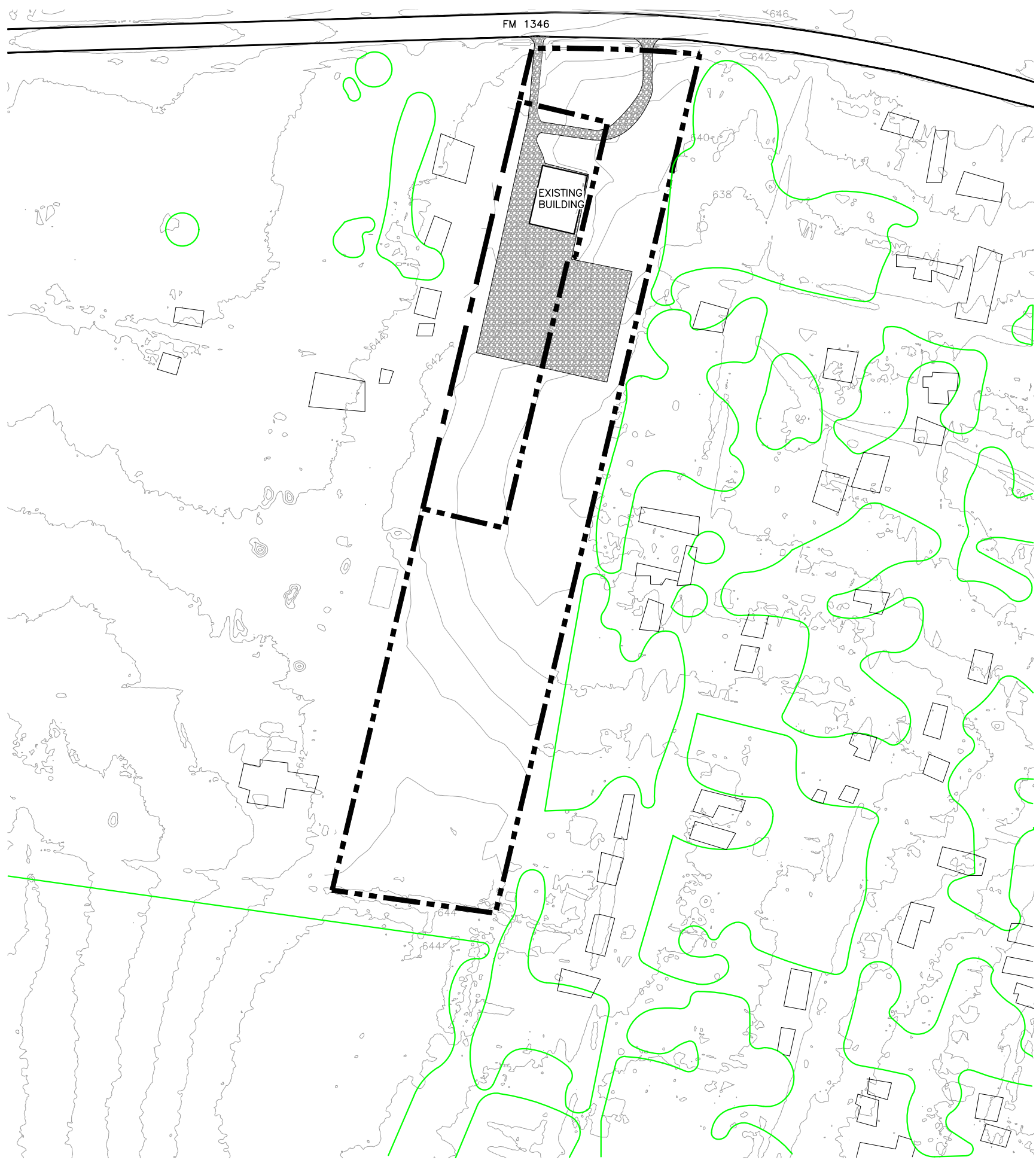

N

0 100 200
SCALE IN FEET

LEGEND

- PERMIT BOUNDARY (SEE NOTE 2)
- PROPERTY BOUNDARY
- EXISTING GRAVEL
- EXISTING TREES
- EXISTING BUILDING

- NOTES:
1. THE EXISTING CONTOURS PROVIDED BY TEXAS RESOURCE INFORMATION SYSTEM (TNRIS) BEXAR AND TRAVIS COUNTIES LIDAR, 2022.
 2. THE PERMIT BOUNDARY WAS PREPARED BY WEAVER CONSULTANTS GROUP, DATED JUNE 6, 2023.

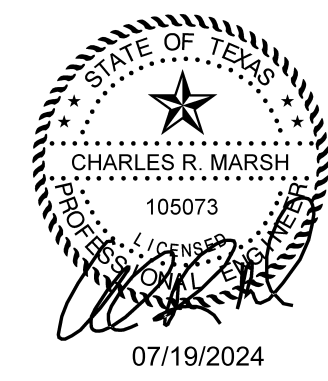

Tech. Complete App. - 042

<input type="checkbox"/> 90% REVIEW <input checked="" type="checkbox"/> FOR PERMITTING PURPOSES ONLY <input type="checkbox"/> ISSUED FOR CONSTRUCTION	PREPARED FOR WASTE CONNECTIONS LONE STAR, INC.	TYPE V PERMIT APPLICATION EXISTING SITE CONDITIONS SAN ANTONIO TRANSFER STATION BEXAR COUNTY, TEXAS									
DATE: 01/2024 FILE: 0601-012-11 CAD: FIG 3.1-EXISTING SITE CONDITIONS.DWG	DRAWN BY: RAA DESIGN BY: MB REVIEWED BY: CRM	<table border="1" style="width: 100%; border-collapse: collapse;"> <thead> <tr> <th colspan="3" style="text-align: center;">REVISIONS</th> </tr> <tr> <th style="width: 5%;">NO.</th> <th style="width: 10%;">DATE</th> <th style="width: 85%;">DESCRIPTION</th> </tr> </thead> <tbody> <tr> <td style="text-align: center;">1</td> <td style="text-align: center;">05/2024</td> <td style="text-align: center;">PERMIT MODIFICATION</td> </tr> </tbody> </table>	REVISIONS			NO.	DATE	DESCRIPTION	1	05/2024	PERMIT MODIFICATION
REVISIONS											
NO.	DATE	DESCRIPTION									
1	05/2024	PERMIT MODIFICATION									
Weaver Consultants Group TBPE REGISTRATION NO. F-3727		WWW.WCGRP.COM FIGURE 1/II-3.1									

O:\0601\12\TYPE V PERMIT APP\PARTS 1-III\CLEAN (07-2024)\FIG 3.1-EXISTING SITE CONDITIONS.dwg, rarrington, 1:2

0:\0601\12\TYPE V PERMIT APP\PARTS 1-II\CLEAN\FIG 4.1-SITE LOCATION MAP.dwg, mbahmani, 1:2

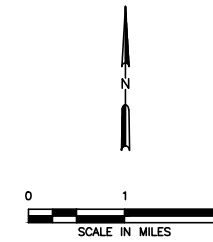

LEGEND

- PERMIT BOUNDARY
- PROPERTY BOUNDARY

- Unincorporated Community
- ⊙ County Seat
- ⊕ Border Crossing
- ⊕ Cemetery
- ⊕ Cemetery (Inside City)
- ⊕ Deep Draft Port
- ⊕ Shallow Draft Port
- Railroad
- Dam
- River or Stream
- TXDOT District
- Lakes
- Education
- Military
- Airport Runway
- Airport
- Prison
- Parks and Other Public Land

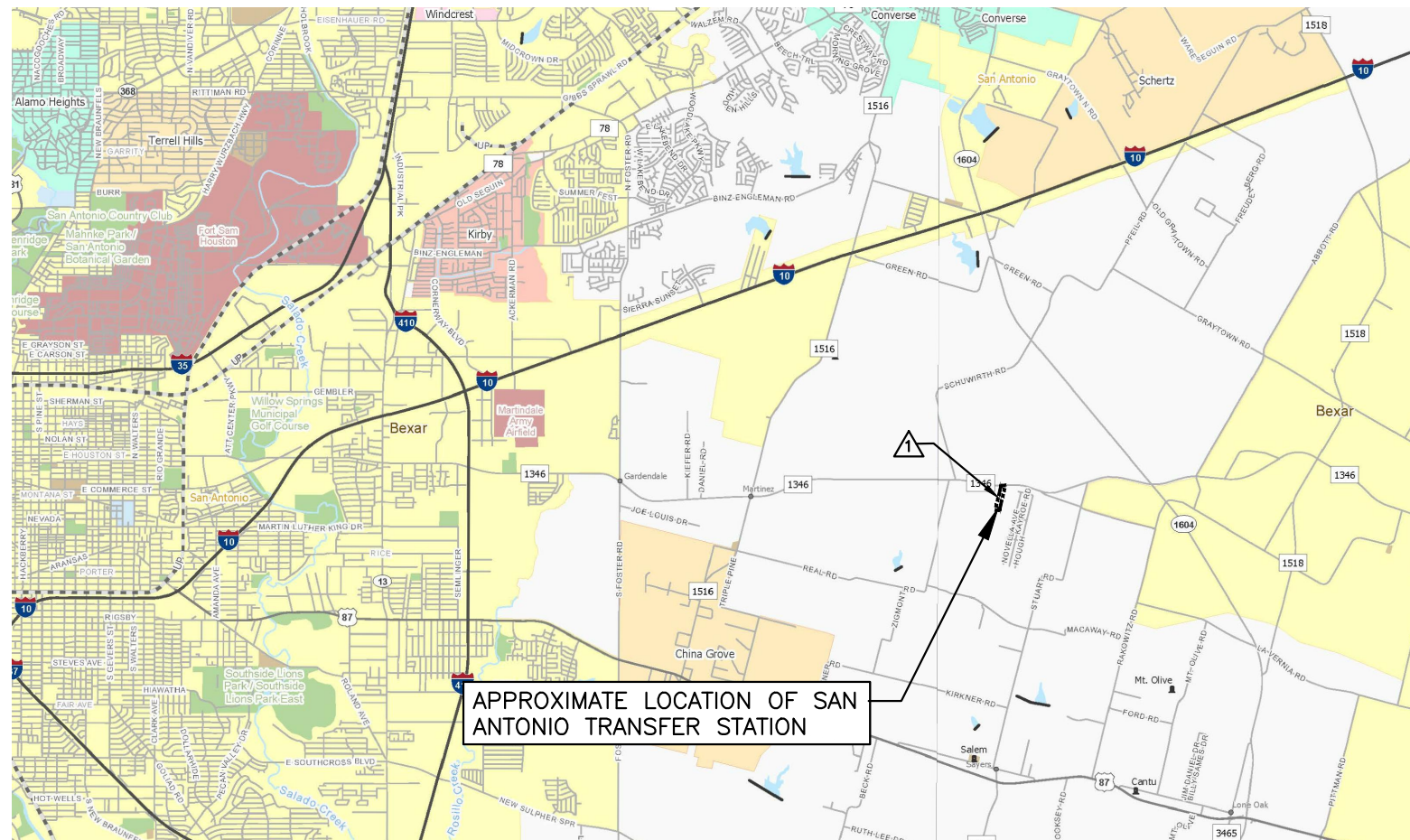

NOTES:

1. REPRODUCED FROM THE COUNTY MAPBOOK 2018 (TEXAS DEPARTMENT OF TRANSPORTATION, TRANSPORTATION PLANNING, AND PROGRAMMING DIVISION).

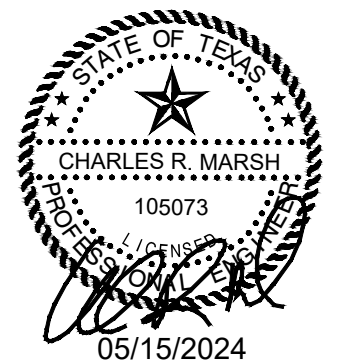

Tech. Complete App. - 043

<input type="checkbox"/> DRAFT <input checked="" type="checkbox"/> FOR PERMITTING PURPOSES ONLY <input type="checkbox"/> ISSUED FOR CONSTRUCTION	PREPARED FOR WASTE CONNECTIONS LONE STAR, INC.		TYPE V PERMIT APPLICATION SITE LOCATION MAP SAN ANTONIO TRANSFER STATION BEXAR COUNTY, TEXAS	
	DATE: 01/2024 FILE: 0601-012-11 CAD: FIG 4.1-SITE LOCATION MAP.DWG	DRAWN BY: RAA DESIGN BY: MB REVIEWED BY: CRM		
Weaver Consultants Group TBPE REGISTRATION NO. F-3727		NO. 1 DATE 05/2024 DESCRIPTION PERMIT MODIFICATION	WWW.WCGRP.COM	
				FIGURE I/II-4.1

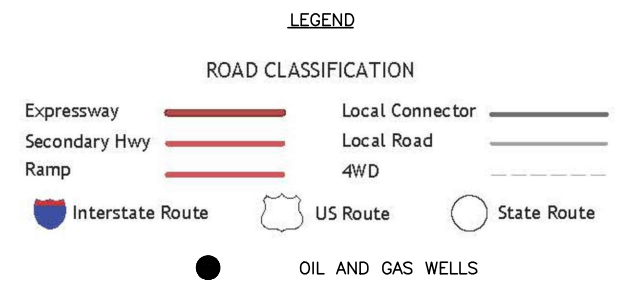
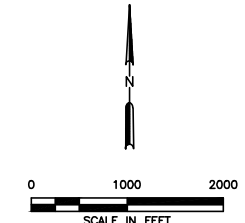
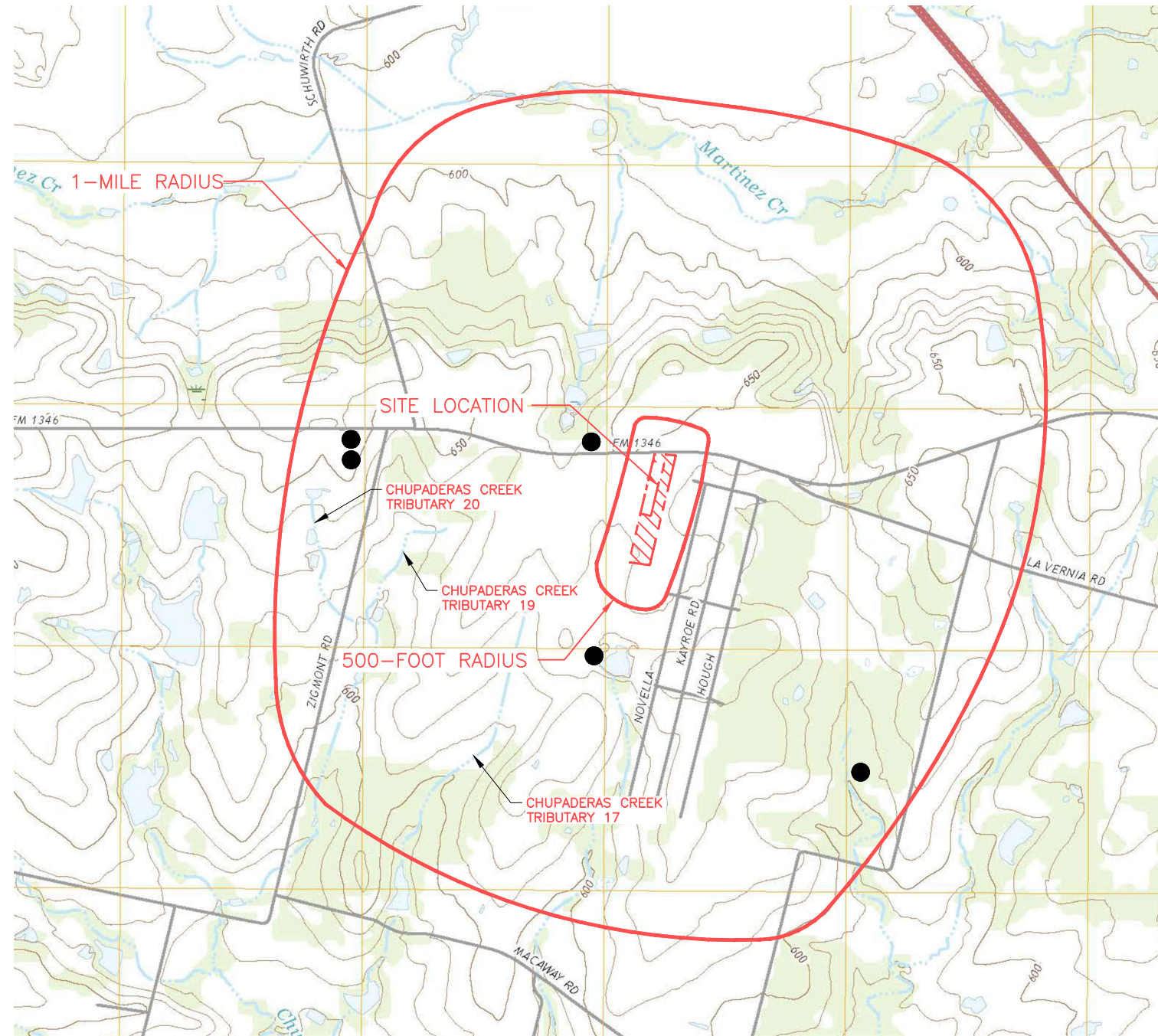

SITE LOCATION
 N 29° 25' 12"
 W 98° 17' 8"

Windrose Plot for [SSF] SAN ANTONIO/STINSON
 Obs Between: 05 Jan 1988 07:00 AM - 27 Feb 2023 06:53 AM America/Chicago

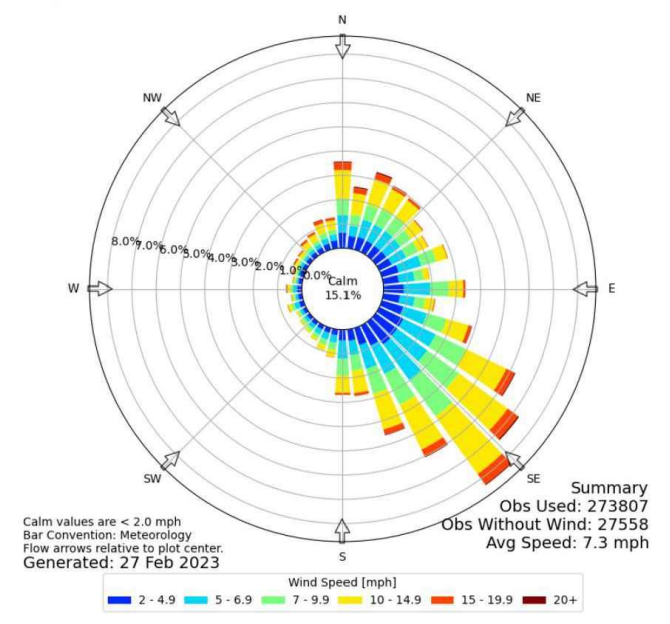

- NOTE:**
- ADAPTED FROM THE USGS 7.5 MINUTE QUADRANGLE TOPOGRAPHIC MAPS (MARTINEZ, TX 2022)
 - THERE ARE NO SPRINGS WITHIN 1 MILE OF THE SITE LOCATION.
 - OIL AND GAS LOCATIONS ARE PROVIDED BY ERIS DATABASE DATED FEBRUARY 7, 2023.
 - WINDROSE IS ADOPTED FROM IOWA STATE UNIVERSITY OF SCIENCE AND TECHNOLOGY, DEPARTMENT OF AGRONOMY.



Tech. Complete App. - 044

<input type="checkbox"/> DRAFT <input checked="" type="checkbox"/> FOR PERMITTING PURPOSES ONLY <input type="checkbox"/> ISSUED FOR CONSTRUCTION	PREPARED FOR WASTE CONNECTIONS LONE STAR, INC.	TYPE V PERMIT APPLICATION GENERAL TOPOGRAPHIC MAP SAN ANTONIO TRANSFER STATION BEXAR COUNTY, TEXAS						
	DATE: 01/2024 FILE: 0601-012-11 CAD: FIG 4.2-GENERAL TOPO MAP.DWG		DRAWN BY: RAA DESIGN BY: MB REVIEWED BY: CRM	REVISIONS <table border="1"> <thead> <tr> <th>NO.</th> <th>DATE</th> <th>DESCRIPTION</th> </tr> </thead> <tbody> <tr> <td>1</td> <td>05/2024</td> <td>PERMIT MODIFICATION</td> </tr> </tbody> </table>	NO.	DATE	DESCRIPTION	1
NO.	DATE	DESCRIPTION						
1	05/2024	PERMIT MODIFICATION						
Weaver Consultants Group TBPE REGISTRATION NO. F-3727		WWW.WCGRP.COM FIGURE 1/II-4.2						

0:\0601\12\TYPE V PERMIT APP\PARTS 1-II\CLEAN\FIG 4.3-AERIAL PHOTOGRAPH.dwg, mubahmani, 1:2

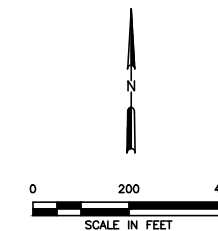

LEGEND

	PERMIT BOUNDARY
	PROPERTY BOUNDARY
	INHABITABLE STRUCTURES
	INDUSTRIAL/COMMERCIAL STRUCTURES
	RESIDENCE
	CHURCH

- NOTES:**
1. AERIAL PHOTOGRAPH PROVIDED BY GOOGLE EARTH DATED AUGUST 9, 2022.
 2. ALL STRUCTURES WITHIN 500 FEET OF THE PERMIT BOUNDARY ARE SHOWN ON THIS FIGURE.
 3. THE NEAREST RESIDENCE IS LOCATED APPROXIMATELY 48 FEET EAST OF THE PERMIT BOUNDARY.

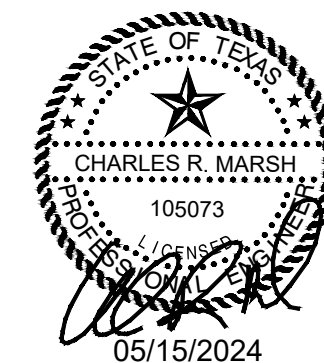

Tech. Complete App. - 045

<input type="checkbox"/> DRAFT <input checked="" type="checkbox"/> FOR PERMITTING PURPOSES ONLY <input type="checkbox"/> ISSUED FOR CONSTRUCTION	PREPARED FOR		WASTE CONNECTIONS LONE STAR, INC.	TYPE V PERMIT APPLICATION AERIAL PHOTOGRAPH					
	DATE: 01/2024 FILE: 0601-012-11 CAD: FIG 6.1-AERIAL PHOTOGRAPH.DWG				DRAWN BY: SRF DESIGN BY: MB REVIEWED BY: CRM				
WEAVER CONSULTANTS GROUP TBPE REGISTRATION NO. F-3727		REVISIONS		SAN ANTONIO TRANSFER STATION BEXAR COUNTY, TEXAS					
		<table border="1"> <thead> <tr> <th>NO.</th> <th>DATE</th> <th>DESCRIPTION</th> </tr> </thead> <tbody> <tr> <td>1</td> <td>05/2024</td> <td>PERMIT MODIFICATION</td> </tr> </tbody> </table>			NO.	DATE	DESCRIPTION	1	05/2024
NO.	DATE	DESCRIPTION							
1	05/2024	PERMIT MODIFICATION							
		WWW.WCGRP.COM		FIGURE 1/II-4.3					

0:\0601\12\TYPE V PERMIT APP\PARTS 1-II\CLEAN\FIG 4.4-PROPOSED SITE PLAN.dwg, mbahman1, 1:2

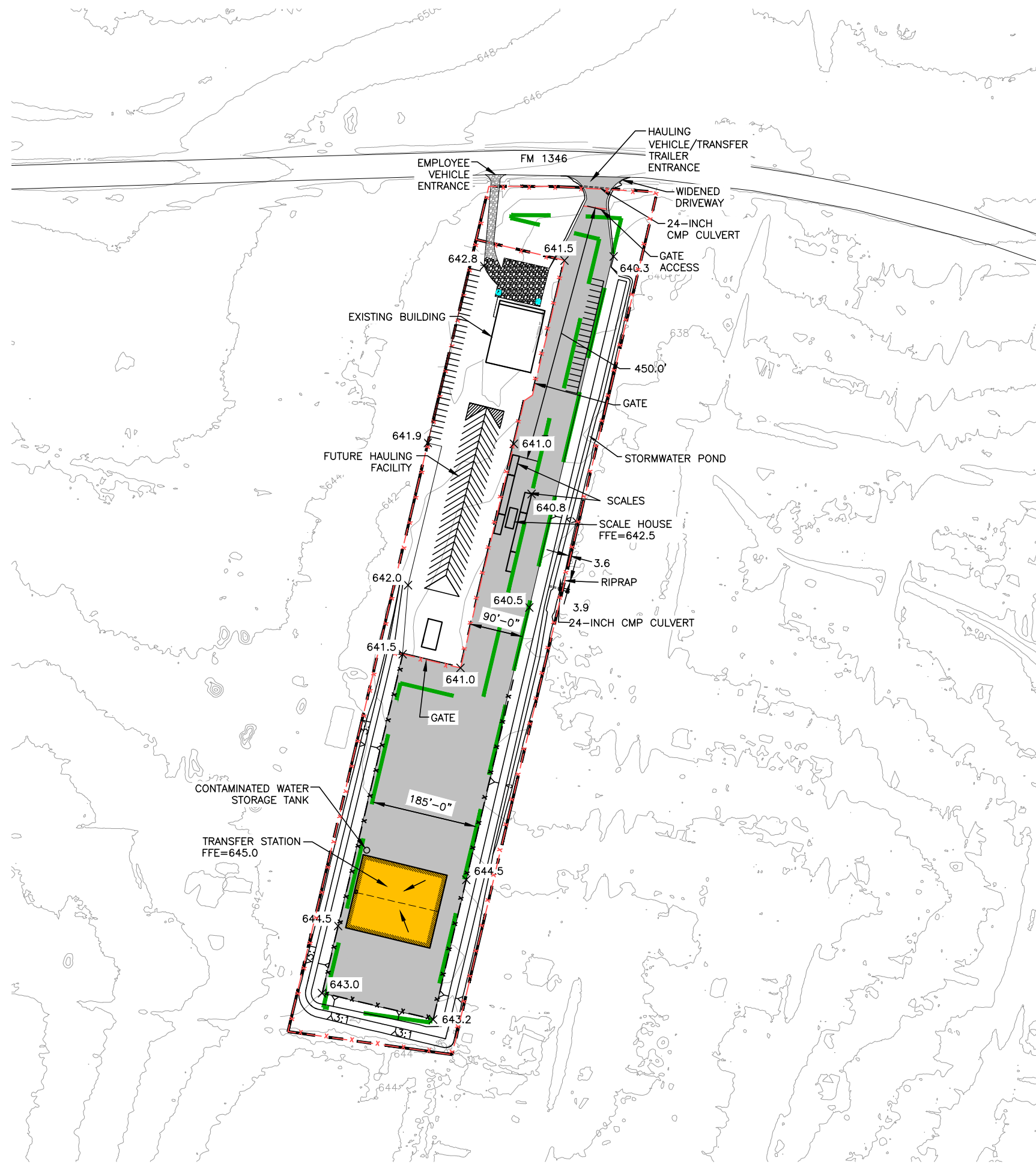

LEGEND

- PERMIT BOUNDARY
- PROPERTY BOUNDARY
- EXISTING CONTOUR
- PROPOSED BUILDING
- EXISTING GRAVEL PAVEMENT
- PROPOSED GRAVEL PAVEMENT
- 50-FOOT BUFFER ZONE
- ACCESS CONTROL FENCE (SEE NOTE 3)
- PROPOSED OPERATIONS AREA FENCE (SEE NOTE 2)
- PROPOSED CONCRETE OR ASPHALT PAVEMENT OR AGGREGATE SURFACE
- PROPOSED SPOT ELEVATION

- NOTES:**
1. THE EXISTING CONTOURS PROVIDED BY TEXAS RESOURCE INFORMATION SYSTEM (TNRIS) BEXAR AND TRAVIS COUNTIES LIDAR, 2022.
 2. THE TRANSFER STATION ACCESS WILL BE CONTROLLED BY A FENCE AROUND THE PROPERTY WITH GATES ON THE FACILITY ENTRANCE ROAD. AREAS WITH DENSE TREES PROVIDE A NATURAL BARRIER AROUND THE EAST SIDE OF THE FACILITY BOUNDARY.
 3. PERIMETER FENCE ACCESS POINTS MAY BE INSTALLED TO FACILITATE SITE MAINTENANCE AND OPERATIONS.

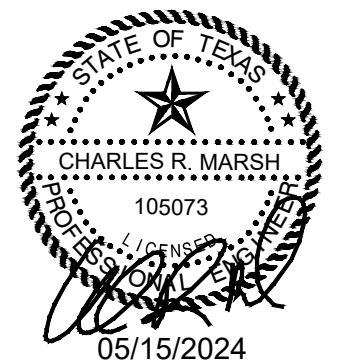

Tech. Complete App. - 046

<input type="checkbox"/> 90% REVIEW <input checked="" type="checkbox"/> FOR PERMITTING PURPOSES ONLY <input type="checkbox"/> ISSUED FOR CONSTRUCTION	PREPARED FOR WASTE CONNECTIONS LONE STAR, INC.	TYPE V PERMIT APPLICATION PROPOSED SITE PLAN SAN ANTONIO TRANSFER STATION BEXAR COUNTY, TEXAS									
DATE: 01/2024 FILE: 0601-012-11 CAD: FIG 4.4-PROPOSED SITE PLAN.DWG	DRAWN BY: RAA DESIGN BY: MB REVIEWED BY: CRM	<table border="1" style="width: 100%; border-collapse: collapse;"> <thead> <tr> <th colspan="3">REVISIONS</th> </tr> <tr> <th>NO.</th> <th>DATE</th> <th>DESCRIPTION</th> </tr> </thead> <tbody> <tr> <td style="text-align: center;">1</td> <td style="text-align: center;">05/2024</td> <td style="text-align: center;">PERMIT MODIFICATION</td> </tr> </tbody> </table>	REVISIONS			NO.	DATE	DESCRIPTION	1	05/2024	PERMIT MODIFICATION
REVISIONS											
NO.	DATE	DESCRIPTION									
1	05/2024	PERMIT MODIFICATION									
Weaver Consultants Group TBPE REGISTRATION NO. F-3727	WWW.WCGRP.COM	FIGURE 1/II-4.4									

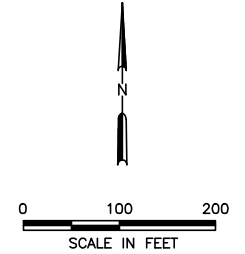

LEGEND

	PERMIT BOUNDARY
	PROPERTY BOUNDARY
	EXISTING CONTOUR
	PROPOSED BUILDING
	EXISTING GRAVEL PAVEMENT
	PROPOSED GRAVEL PAVEMENT
	50-FOOT BUFFER ZONE
	EXISTING EASEMENT
	PROPOSED CONCRETE OR ASPHALT PAVEMENT OR AGGREGATE SURFACE

- NOTES:**
1. THE EXISTING CONTOURS PROVIDED BY TEXAS RESOURCE INFORMATION SYSTEM (TNRIS) BEXAR AND TRAVIS COUNTIES LIDAR, 2022.
 2. THE TRANSFER STATION ACCESS WILL BE CONTROLLED BY A FENCE AROUND THE PROPERTY WITH GATES ON THE FACILITY ENTRANCE ROAD. AREAS WITH DENSE TREES PROVIDE A NATURAL BARRIER AROUND THE EAST SIDE OF THE FACILITY BOUNDARY.
 3. PERIMETER FENCE ACCESS POINTS MAY BE INSTALLED TO FACILITATE SITE MAINTENANCE AND OPERATIONS.

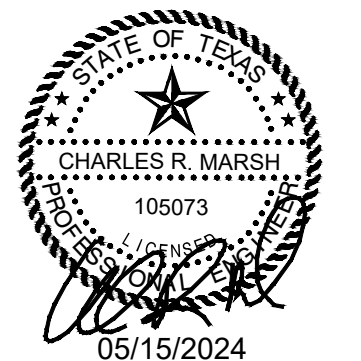

Tech. Complete App. - 047

<input type="checkbox"/> 90% REVIEW <input checked="" type="checkbox"/> FOR PERMITTING PURPOSES ONLY <input type="checkbox"/> ISSUED FOR CONSTRUCTION	PREPARED FOR WASTE CONNECTIONS LONE STAR, INC.		TYPE V PERMIT APPLICATION EASEMENT PLAN	
	DATE: 01/2024 FILE: 0601-012-11 CAD: FIG 4.5-EASEMENT PLAN.DWG	DRAWN BY: RAA DESIGN BY: MB REVIEWED BY: CRM	REVISIONS	
Weaver Consultants Group TBPE REGISTRATION NO. F-3727		NO. 1 DATE 05/2024 DESCRIPTION PERMIT MODIFICATION	WWW.WCGRP.COM FIGURE 1/II-4.5	

O:\0601\12\TYPE V PERMIT APP\PARTS 1-II\CLEAN\FIG 4.5-EASEMENT PLAN.dwg, mbahmani, 1:2

0:\0601\12\TYPE V PERMIT APP\PARTS 1-II\FIG 4.2-TOPO MAP.dwg, smurrcy, 1:2

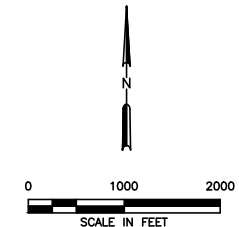
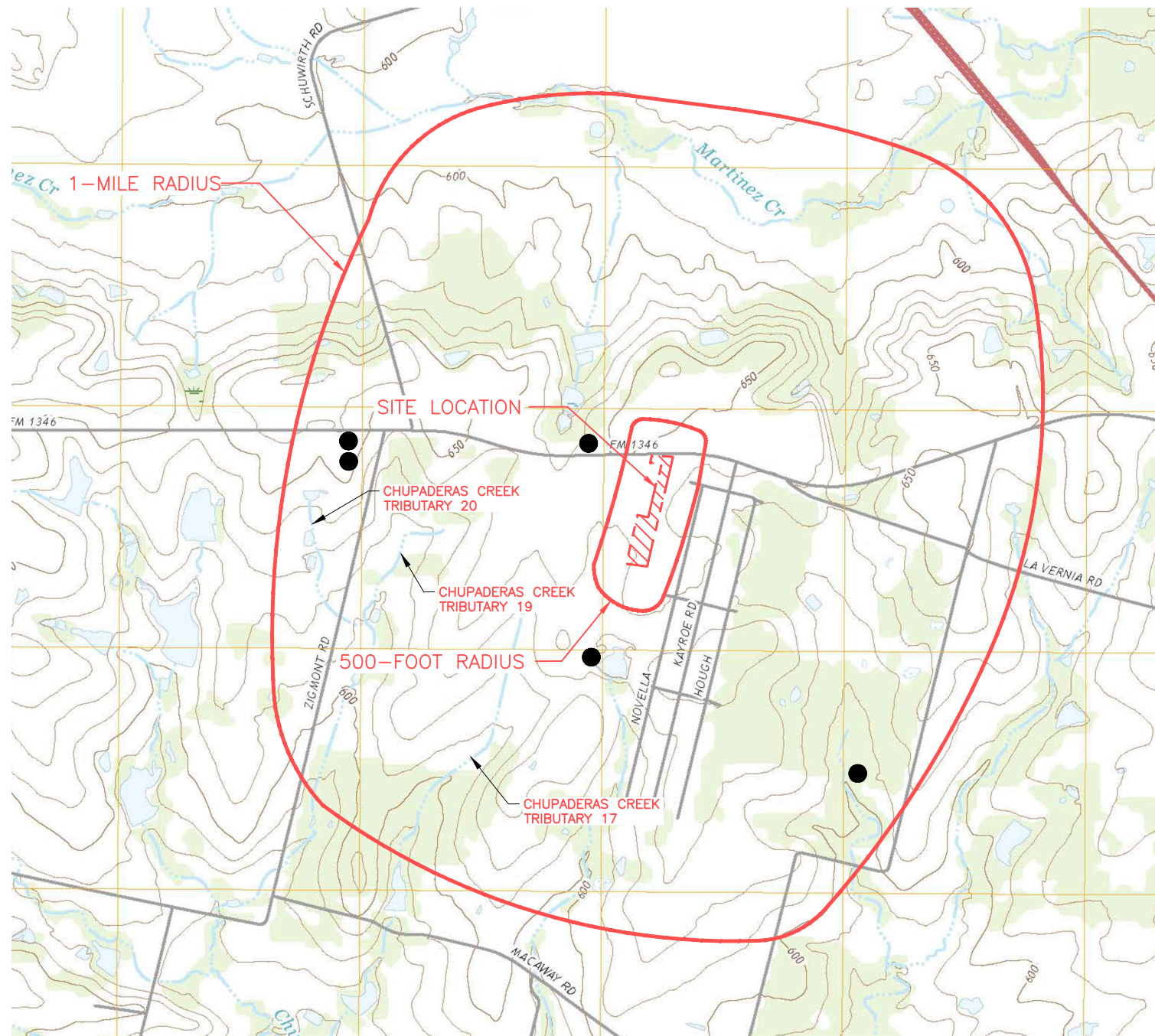

LEGEND

ROAD CLASSIFICATION

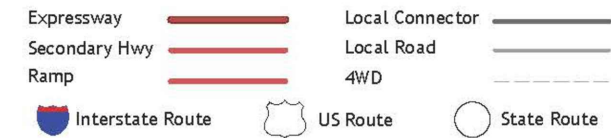

● OIL AND GAS WELLS

SITE LOCATION	
N	29° 25' 12"
W	98° 17' 8"

Windrose Plot for [SSF] SAN ANTONIO/STINSON
Obs Between: 05 Jan 1988 07:00 AM - 27 Feb 2023 06:53 AM America/Chicago

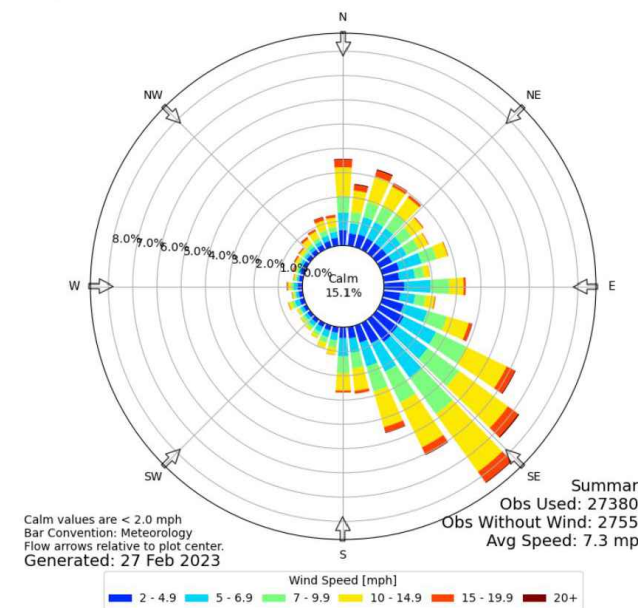

NOTE:

1. ADAPTED FROM THE USGS 7.5 MINUTE QUADRANGLE TOPOGRAPHIC MAPS (MARTINEZ, TX 2022)
2. THERE ARE NO SPRINGS WITHIN 1 MILE OF THE SITE LOCATION.
3. OIL AND GAS LOCATIONS ARE PROVIDED BY ERIS DATABASE DATED FEBRUARY 7, 2023.

Tech. Complete App. - 048

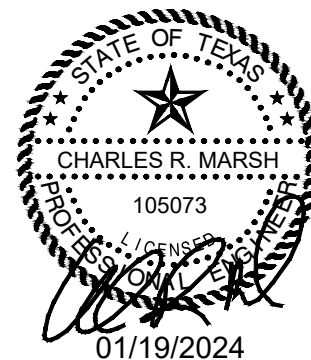

<input type="checkbox"/> DRAFT <input checked="" type="checkbox"/> FOR PERMITTING PURPOSES ONLY <input type="checkbox"/> ISSUED FOR CONSTRUCTION	PREPARED FOR	TYPE V PERMIT APPLICATION GENERAL TOPOGRAPHIC MAP								
	LEALCO, INC.		SAN ANTONIO TRANSFER STATION BEXAR COUNTY, TEXAS							
DATE: 01/2024 FILE: 0601-012-11 CAD: FIG 4.2-GENERAL TOPO MAP.DWG	DRAWN BY: RAA DESIGN BY: MB REVIEWED BY: CRM	WWW.WCGRP.COM FIGURE 1/II-4.2								
REVISIONS <table border="1"> <thead> <tr> <th>NO.</th> <th>DATE</th> <th>DESCRIPTION</th> </tr> </thead> <tbody> <tr> <td> </td> <td> </td> <td> </td> </tr> <tr> <td> </td> <td> </td> <td> </td> </tr> </tbody> </table>			NO.	DATE	DESCRIPTION					
NO.	DATE	DESCRIPTION								
Weaver Consultants Group TBPE REGISTRATION NO. F-3727										

5 PROPERTY OWNERS LIST AND MAP

The following list (Table 5-1) and figure (Figure I/II-5.1) provide the names, mailing addresses, and locations of the adjacent and potentially affected landowners around the facility. The list is based on the Bexar County Appraisal District records as of July 2023 and includes tracts within 1/4 mile of the property boundary. Refer to Figure I/II-5.1, Property Owners Map, for the location of the properties. The numbers on the landowners list correspond to the numbers listed on Figure I/II-5.1. No mineral interests are identified in the Bexar County Appraisal District records.

*This section
addresses
§ 330.59(c)(3) and
§ 305.45(a)(6)(D).*

0:\0601\12\TYPE V PERMIT APP\PARTS 1-II\CLEAN\FIG 5.1-LAND OWNER MAP.dwg, mbahmani, 1:2

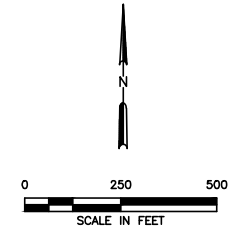

LEGEND

	PERMIT BOUNDARY
	PROPERTY BOUNDARY
	PROPERTY BOUNDARY LINES
	PROPERTY OWNER DESIGNATION

NOTES:

1. PROPERTY BOUNDARIES AND OWNER INFORMATION PROVIDED BY BEXAR COUNTY TAX APPRAISAL WEBSITE, AND APPRAISAL DISTRICT RECORDS AS OF JULY 2023.
2. REFERS TO PROPERTY OWNERS LISTED ON PROPERTY OWNERS LIST IN SECTION 5, PROPERTY OWNERS LIST AND MAP.

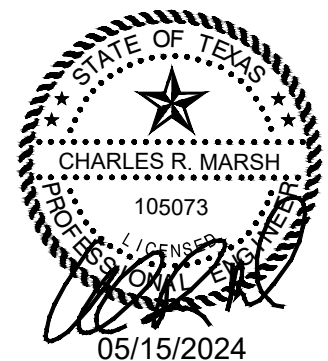

Tech. Complete App. - 050

<input type="checkbox"/> DRAFT <input checked="" type="checkbox"/> FOR PERMITTING PURPOSES ONLY <input type="checkbox"/> ISSUED FOR CONSTRUCTION	PREPARED FOR		WASTE CONNECTIONS LONE STAR, INC.	TYPE V PERMIT APPLICATION LAND OWNER'S MAP
	DATE: 01/2024 FILE: 0601-012-11 CAD: FIG 5.1-LAND OWNER'S MAP.DWG			
		REVISIONS		
		NO.	DATE	DESCRIPTION
		1	02/2024	REVISED PROPERTY OWNER DESIGNATION 139
		2	05/2024	PERMIT MODIFICATION
Weaver Consultants Group TBPE REGISTRATION NO. F-3727		WWW.WCGRP.COM		SAN ANTONIO TRANSFER STATION BEXAR COUNTY, TEXAS
				FIGURE I/II-5.1

Table 5-1 Property Owners List

- | | |
|--|--|
| 1. JASON E KNOWLES &
KAREN D KNOWLES
PO BOX 708
ADKINS TX 78101 | 11. ROSE M BOLDEN
622 NOVELLA AVENUE
ADKINS TX 78101-9708 |
| 2. GLORIA SOSA
10276 FM 1346
ADKINS TX 78101 | 12. SUSANA LINO SOTO
707 NOVELLA AVENUE
ADKINS TX 78101-9729 |
| 3. ERNES WASHINGTON &
CHERYL WASHINGTON
PO BOX 458
HOODSPORT WA 98548-0458 | 13. TAMIKA L PITTS
16039 GINO PARK
SAN ANTONIO TX 78247-6615 |
| 4. RICARDO TORRES-ALVARES &
DENISE TORRES
2439 NE LOOP
APT 1001
SAN ANTONIO TX 78217 | 14. JB BOLDEN & ROSE BOLDEN
622 NOVELLA AVENUE
ADKINS TX 78101-9708 |
| 5. SANDRA YOLANDA L PERKINS
5830 GOODYEAR DR
SAN ANTONIO TX 78228-3409 | 15. ALVARADO AMELIA
727 NOVELLA AVENUE
ADKINS TX 78101-9729 |
| 6. CLIFTON EUGENE RODGERS
467 LINCOLNSHIRE DR
SAN ANTONIO TX 78220-4248 | 16. ELOSIA ALVARADO
803 NOVELLA AVENUE
ADKINS TX 78101-3350 |
| 7. ROBERT MOORE & IRNE A MOORE
603 NOVELLA AVENUE
ADKINS TX 78101-9455 | 17. ROMELIA DAYIL A SANCHEZ
C/S % RAVL MARTINEZ
811 NOVELLA AVENUE
ADKINS TX 78101-3350 |
| 8. MEYBEL P VALLE SANCHEZ
619 NOVELLA AVENUE
ADKINS TX 78101 | 18. ALFRED S CASAS & PATRICIA J CASAS
435 E DREXEL AVENUE
SAN ANTONIO TX 78210-3004 |
| 9. MARIA N SHNTILLAN
18755 FONTLEE LN
BLOOMINGTON CA 92316-1564 | 19. PEDRO TORRES
1127 NOVELLA AVENUE
ADKINS TX 78101-9761 |
| 10. MARIA CASTRO LOPEZ
623 NOVELLA AVENUE
ADKINS TX 78101-9455 | 20. PRISCILLA ALFREDA &
GARY CHARLES PATTERSON
2330 RUBY OAKS
SAN ANTONIO TX 78232-5600 |

Table 5-1
Property Owners List (Continued)

- | | |
|---|--|
| 21. HRCHIE CLARK
HENRY ETAL
905 NOVELLA AVENUE
ADKINS TX 78101-3351 | 31. PEDRO TORRES
1127 NOVELLA AVENUE
ADKINS TX 78101-9761 |
| 22. BENNIE L MITCHELL
1525 W 125 TH STREET
LOS ANGELES CA 90047-5330 | 32. INOCENTE GONZALEZ
1007 NOVELLA AVENUE
ADKINS TX 78101-3352 |
| 23. PAUL DELGADO & NIKKO DELGADO
10090 FM 1346
ADKINS TX 78101-3330 | 33. LLOYD A JR MAJETTE ETAL
1015 NOVELLA AVENUE
ADKINS TX 78101-3352 |
| 24. RDZ PAVING LLC
10194 FM 1346
ADKINS TX 78101-3329 | 34. JENNIFER V KODKIGUEZ
C/S % DALIA STEVENSON
1109 NOVELLA AVENUE
ADKINS TX 78101-9761 |
| 25. STEVE WOODS ET AL
3515 LAKE FOUNTAIN
SAN ANTONIO TX 78217 | 35. PAUL ANTHONY RODRIGUEZ
1113 NOVELLA AVENUE
ADKINS TX 78101-9761 |
| 26. RAYMOND L GEYER
10116 FM 1346
ADKINS TX 78101-3329 | 36. JOSE F CORNEJO
1117 NOVELLA AVENUE
ADKINS TX 78101-9778 |
| 27. GERARDO JR MARTINEZ &
IRMA ROSA
10048 FM 1346 #1
ADKINS TX 78101-3330 | 37. PEDRO TORRES &
BLANCA E TORRES
1127 NOVELLA AVENUE
ADKINS TX 78101-9761 |
| 28. GERARDO F MARTINEZ &
GLORIA C MARIA
10048 FM 1346
ADKINS TX 78101-3330 | 38. TUNAS TRES RANCH LLC
20908 CACTUS LOOP
SAN ANTONIO TX 78258 |
| 29. LARRY W SMITH &
DEBRA A SMITH
9940 FM 1346
ADKINS TX 78101-9792 | 39. ANDY BLOODWORTH & TAMMY
BLOODWORTH & TUNAS TRES
RANCH LLC
10419 FM 1346
ADKINS TX 78101-3325 |
| 30. HELEN R ADAMS
903 NOVELLA AVENUE
ADKINS TX 78101-9792 | 40. THEODORE ELOISE DRZMALLA
PO BOX 279
ADKINS TX 78101-0279 |

**Table 5-1
Property Owners List (Continued)**

- | | |
|--|---|
| 41. THEODORE ELOISE DRZYMALLA
PO BOX 279
ADKINS TX 78101-5000 | 51. MC INTTRE ELROY
10318 FM 1346
ADKINS TX 78101-3331 |
| 42. EUSTAQUIO VARELA
3491 RAKOWITZ RD
ADKINS TX 78101-5000 | 52. HENRY FIELDS LEE ET AL
10318 FR 1346
ADKINS TX 78101-3331 |
| 43. CARL RAY DRZYMALLA &
LINDA DRZYMALLA
10115 FM 1346
ADKINS TX 78101-3317 | 53. JUANITA GONZALEZ
1007 NOVELLA AVENUE
ADKINS TX 78101-3352 |
| 44. AMANDA RAEANNE REAL
10115 FM 1346
ADKINS TX 78101-3317 | 54. WAUTERS ENGINEERING
12870 ADKINS SAINT HEDWIG RD
SAINT HEDWIG TX 78152 |
| 45. MARIO SALINAS
150 LANTANA RDG
SPRING BRANCH TX 78070 | 55. TRUE CHRISTIAN UNITY CHURCH
10311 LEE ROY LN
ADKINS TX 78101 |
| 46. CLAYTON CICHON & STEPHANIE
CHICHON & MONICA MAGSAM
9955 FM 1346
ADKINS TX 78101 | 56. RACHEL WASHINGTON EVETTE
10303 LEE ROY LN
ADKINS TX 78101 |
| 47. SAMUEL SOSA
10276 FM 1346
ADKINS TX 78101-9705 | 57. THOMAS JONES & SHELLY A JONES
6206 GORDON COOPER DR
SAN ANTONIO TX 78219-2043 |
| 48. YOLANDA RUIZ & FRANCISCO ORTIZ
10334 LEE ROY LN
ADKINS TX 78101 | 58. NICOLE M MITCHELL
607 KAYROE RD
ADKINS TX 78101-9799 |
| 49. ORLANDO NAVARRO MARTINEZ
710 HOUGH
ADKINS TX 78101 | 59. FRANK E DANIELS
622 KAYROE RD
ADKINS TX 78101-9793 |
| 50. ERNEST WASHINGTON
PO BOX 458
HOODSPORT WA 98548-0458 | 60. JANNIE B DEARMON ET AL
10302 LEE ROY LN
ADKINS TX 78101 |

Table 5-1
Property Owners List (Continued)

- | | |
|--|--|
| 61. GUADALUPE C CARREON &
VERONICA L C/S
6389 FOX RUN
SAN ANTONIO TX 78233-4710 | 71. MARY ELLEN & JESUS ACOSTA
726 NOVELLA AVENUE
ADKINS TX 78101 |
| 62. ROGELIO ZAMBRAND
102 VIKING OAK
SAN ANTONIO TX 78247-3305 | 72. ROSE MCGARITY
5918 PLEASANT LK
SAN ANTONIO TX 78222-3336 |
| 63. J B BOLDEN & ROSE BOLDEN
622 NOVELLA AVENUE
ADKINS TX 78101-9708 | 73. KEVIN HERMES
444 ATLANTA PARK DR
GEORGETOWN TX 78628 |
| 64. WILLIAM LLOYD EST OF
622 NOVELLA AVENUE
ADKINS TX 78101-9708 | 74. SYLVIA MICHELLE CORTEZ &
GIOVANNIE ADYN RAMON GAYTAN
152 W WILDWOOD
SAN ANTONIO TX 78212-1566 |
| 65. LLOYD WILLIAMS
C/O ROSE BOLDEN
622 NOVELLA AVENUE
ADKINS TX 78101-9708 | 75. HENRY LEE & TRILLIS FIELDS
822 NOVELLA AVENUE
ADKINS TX 78101-3349 |
| 66. BELLO MARY FRANCES V
706 NOVELLA AVENUE
ADKINS TX 78101-9797 | 76. ELIJAH SMITH
6915 MCCULLUM RD
MISSOURI CITY TX 77489 |
| 67. ERNESTO MARY F &
MIGUEL BELLO
706 NOVELLA AVENUE
ADKINS TX 78101-9797 | 77. SANDRA RUIZ
840 NOVELLA AVENUE
ADKINS TX 78101-3349 |
| 68. BENJAMIN & GRACIELA CAMPOS
710 NOVELLA AVENUE
ADKINS TX 78101-9797 | 78. JUAN CARLOS RUIZ
902 NOVELLA AVENUE
ADKINS TX 78101-9463 |
| 69. ROBERT WASHINGTON
811 W WW WHITE RD
SAN ANTONIO TX 78220-2526 | 79. RAYMOND J & FRANCIS MARTINEZ
914 NOVELLA AVENUE
ADKINS TX 78101-9758 |
| 70. SANDRA GARZA
722 NOVELLA AVENUE
ADKINS TX 78101 | 80. BERNABE CORNEJO & GLORIA SOTO
1014 NOVELLA AVENUE
ADKINS TX 78101-9758 |

**Table 5-1
Property Owners List (Continued)**

- | | |
|---|--|
| 81. GAVINO ELOY RUIZ
1018 NOVELLA AVENUE
ADKINS TX 78101-9758 | 91. RAYMOND JR & CARMEN P
WILLIAMSON
703 KAYROE RD
ADKINS TX 78101-9722 |
| 82. LORENA RUIZ
1102 NOVELLA AVENUE
ADKINS TX 78101-3365 | 92. JESSIE GUTIERREZ
PO BOX 201324
SAN ANTONIO TX 78220 |
| 83. LORENA RUIZ
1054 NOVELLA AVENUE
ADKINS TX 78101 | 93. TONY R ROMO
200 BRENNER ST
SAN ANTONIO TX 78237-2913 |
| 84. JASON & CARMEN RODRIGUEZ
1106 NOVELLA AVENUE
ADKINS TX 78101-3363 | 94. DIANA S CAMPOS & JEANNIE
CAMPOS MONTALVO
719 KAYROE RD
ADKINS TX 78101-9722 |
| 85. SANTIAGO & SYLVIA VILLASENOR
1134 NOVELLA AVENUE
ADKINS TX 78101-3353 | 95. DENISE CAMPOS SANCHEZ
719 KAYROE RD
ADKINS TX 78101-9722 |
| 86. PATRICIA & SYLVIA VILLASENOR
1134 NOVELLA AVENUE
ADKINS TX 78101-3365 | 96. MARSHALL SIDBERRY VENTURES INC
PO BOX 91231
SAN ANTONIO TX 78209-9098 |
| 87. JOSE MIGUEL & VICTOR
QUIROZ FIGUEROA
255 LANGFORD PL
SAN ANTONIO TX 75221-2443 | 97. EUGENE MORALES &
SANTIAGO VILLEGAS
791 KAYROE RD
ADKINS TX 78101 |
| 88. JOYCE MCGARY WINKFIELD
3103 LASSES BLVD
SAN ANTONIO TX 78223-4147 | 98. SANTIAGO S VILLEGAS
791 KAYROE RD
ADKINS TX 78101-9722 |
| 89. KEVIN YAIR GUEVARA &
MARIA DOLORES G TR RODRIGUEZ
106 HIGH OAK DR
UNIVERAL CITY TX 78148 | 99. ROBERT CAVIL COLEMAN
C/O ROSE MCGARITY
5918 PLEASANT LK
SAN ANTONIO TX 78222-3336 |
| 90. GUADALUPE ALANIS RODRIGUEZ
7650 CLAREWOOD DR
APT 4
HOUSTON TX 77036-4949 | 100. MARGARET COLEMAN
2130 S WW WHITE RD
APT 416
SAN ANTONIO TX 78222-1136 |

Table 5-1
Property Owners List (Continued)

- | | |
|--|--|
| 101. LEON A HERNANDEZ
830 KAYROE RD
ADKINS TX 78101-3344 | 111. DAVID RUIZ
1107 KAYROE RD
ADKINS TX 78101-9766 |
| 102. LEON JR & DORIS HERNANDEZ
831 KAYROE RD
ADKINS TX 78101-3345 | 112. GEORGE RUIZ
1119 KAYROE RD
ADKINS TX 78101-3348 |
| 103. RAY SOSA
903 KAYROE RD
ADKINS TX 78101-9453 | 113. HEBERTO TORREZ MOSQUEDA
1123 KAYROE RD
ADKINS TX 78101-3348 |
| 104. RUBEN M & LUCIO O SOSA
907 KAYROE RD
ADKINS TX 78101-9453 | 114. MARGARITA GUERRERO
1127 KAYROE RD
ADKINS TX 78101 |
| 105. YULMA Y AGUIRRE VALLES
17525 FARGOER WAY
MARION TX 78124-6606 | 115. NO OWNER LISTED |
| 106. KIA GRIFFIN
919 KAYROE RD
ADKINS TX 78101-9453 | 116. MRS EULA HOWARD
% JOEL REESE
PO BOX 202026
SAN ANTONIO TX 78220-9026 |
| 107. GEORGE S RUIS
16725 BLUE BREEZE
ELMENDORF TX 78112 | 117. JACK REESE
1106 KAYROE RD
ADKINS TX 78101 |
| 108. LUCIA ALVARADO
1011 KAYROE RD
ADKINS TX 78101-9766 | 118. JOEL REESE
5718 COLDSPRINGS DR
SAN ANTONIO TX 78244-1202 |
| 109. ELOY G RUIZ
1039 KAYROE RD
ADKINS TX 78101-9766 | 119. PATRICIA ALEGRIA
1102 KAYROE RD
ADKINS TX 78101-9706 |
| 110. ELOY RUIZ
1018 NOVELLA AVENUE
ADKINS TX 7801-9758 | 120. HEBERTO TORREZ
1123 KAYROE RD
ADKINS TX 78101-3348 |

Table 5-1
Property Owners List (Continued)

- | | |
|--|--|
| 121. FRANCISCO J NEGRETE TORRES
21771 CHERRY ST
NEW CANEY TX 77357-4221 | 131. LEON A & ERNESTINA HERNANDEZ
830 KAYROE RD
ADKINS TX 78101-3344 |
| 122. VINCENT & ANNA M MARTINEZ
1027 HOUGH
ADKINS TX 78101-9773 | 132. RAYMOND & JEANNIE C
MONTALVO
810 KAYROE RD
ADKINS TX 7811-3344 |
| 123. ESTATE OF EDWARD JONES
623 ROTARY
SAN ANTONIO TX 78202-2645 | 133. RAYMOND ET AL C/S
EDWARDS ROSS MONTALVO
810 KAYROE RD
ADKINS TX 78101-3344 |
| 124. LORENZO B III & DORA ESQUEDA
1014 KAYROE RD
ADKINS TX 78101 | 134. TANISHA JOHNSON
754 KAYROE RD
ADKINS TX 78101 |
| 125. TINA SPRAGUE & DONNA L
CHRISTY
1010 KAYROE RD
ADKINS TX 78101-3347 | 135. RION C & HANNA PEREZ
726 KAYROE RD
ADKINS TX 78101 |
| 126. DONNA L CHRISTY
1010 KAYROE RD
ADKINS TX 78101-3347 | 136. SHIRLEY MACKEY
714 KAYROE RD
ADKINS TX 78101-9796 |
| 127. MARIA C LOPEZ
1202 NOVELLA AVENUE
ADKINS TX 78101 | 137. MARIA CASTRO LOPEZ
623 NOVELLA AVENUE
ADKINS TX 78101-9455 |
| 128. CECILE BIGGAS
2126 N VILLERE ST
NEW ORLEANS LA 70116-1516 | 138. TERRY VIVIER & JOHNNA MERLA
704 KAYROE RD
ADKINS TX 78101 |
| 129. GILBERT GONZALEZ
906 KAYROE RD
ADKINS TX 78101-3346 | 139. FRANK E DANIELS
622 KAYROE RD
ADKINS TX 78101-9793 |
| 130. WEMICK HOLDINGS LLC
835 OTTAWA WAY ST
SAN ANTONIO TX 78260 | 140. OCTAVIO GARCIA
616 KAYROE RD
ADKINS TX 7811-9793 |

Table 5-1
Property Owners List (Continued)

- | | |
|---|--|
| 141. ESTATE OF LESLIE THOMAS ST
611 KAYROE RD
ADKINS TX 78011-9799 | 151. VICTOR FIGUEROA QUIROZ
667 HOUGH AVENUE
ADKINS TX 78101 |
| 142. RODNEY A & MONICA L
10318 LEE ROY LN
ADKINS TX 78101-9707 | 152. ARMANDO LARES
702 HOUGH AVENUE
ADKINS TX 78101-9811 |
| 143. JAMES FRANCICS
10315 LEE ROY LN
ADKINS TX 78101 | 153. GRACIELA B & FRANK MARTINEZ
711 HOUGH AVENUE
ADKINS TX 78101-9768 |
| 144. YOLANDA Y GARRISON
651 S MEL WAITERS WAY
APT 504
SAN ANTONIO TX 78203 | 154. ROSS DEE & CHERYL RENEE WEBB
2600 NE LOOP 410
APT 2307
SAN ANTONIO TX 78217-5623 |
| 145. ELEAZAR BARRIENTOS
10338 FM 1346
ADKINS TX 78101-3331 | 155. JESUS MARTINEZ
727 HOUGH AVENUE
ADKINS TX 78101 |
| 146. MARY L MENDOZA
10498 FM 1346
ADKINS TX 7811-3332 | 156. MARIA G AROCHA
1228 RIGSBY AVENUE
SAN ANTONIO TX 78210-3150 |
| 147. ANTONIO O CANALES
10338 FM 1346
ADKINS TX 78101-3331 | 157. JOSUE & DAMARIS NEGRETE AVINA
16240 SAN PEDRO #120
SAN ANTONIO TX 78232 |
| 148. SHELTON MACKAY
10334 FM 1346
LOT 2
ADKINS TX 78101-3388 | 158. BRENDA LOPEZ
819 HOUGH AVENUE
ADKINS TX 78101-9465 |
| 149. YOLANDA R & FRANCISCO ORTIZ
10334 LE ROY LN
ADKINS TX 78101-9707 | 159. JACKSON CRISPIN &
BRENDA L MALDONADO
819 HOUGH AVENUE
ADKINS TX 78101-9465 |
| 150. LEE A & VIRGIE M RICHARDSON
922 BURNET ST
SAN ANTONIO TX 78202-2301 | 160. WILLIAM B COOK
823 HOUGH VENUE
ADKINS TX 78101-9465 |

Table 5-1
Property Owners List (Continued)

- | | |
|--|--|
| 161. ISMAEL & LAURIE MORENO
& ANGELINA GONZALEZ
1227 WESTFALL AVENUE
SAN ANTONIO TX 78210 | 171. JUVENAL & CLAUDIA A GOMEZ
6102 CALLEY CLF
SAN ANTONIO TX 78250-5757 |
| 162. GWEN GARRETT &
FRANK BLANCO
903 HOUGH AVENUE
ADKINS TX 78101-9466 | 172. TERESA M JUAREZ
1107 HOUGH AVENUE
ADKINS TX 78101-9769 |
| 163. PEDRO TORRES
1127 NOVELLA AVENUE
ADKINS TX 78101 | 173. TIANA LORRAINE DELOYOLA
1109 HOUGH AVENUE
ADKINS TX 78101 |
| 164. MARINA CONDE
911 HOUGH AVENUE
ADKINS TX 78101-9466 | 174. MEGAN RAE & JAMES
BELL SAPENTER
919 H ST
SAN ANTONIO TX 78220-4217 |
| 165. HERIBERTO & BRINDY MALDONADO
923 HOUGH AVENUE
ADKINS TX 78101 | 175. BRUNO & ROSE MENDOZA
614 HOUGH AVENUE
ADKINS TX 78101-3316 |
| 166. DONNIE R & IRMA J
FRIESENHAHN
1003 HOUGH AVENUE
ADKINS TX 78101-9460 | 176. JOE III & CLARA ALVARADO
618 HOUGH AVENUE
ADKINS TX 78101-3316 |
| 167. BILLIE RUTH WILLIAMS
4273 MCCLUNG DR
LOS ANGELES CA 90008-4441 | 177. ORLANDO & JOCELYN NAVARRO
710 HOUGH AVENUE
ADKINS TX 78101-9710 |
| 168. ARMANDO RIVAS LARES
702 HOUGH AVENUE
ADKINS TX 78110 | 178. PEDRO TORRES
1127 NOVELLA AVENUE
ADKINS TX 78101-9761 |
| 169. CAROLINA M CONTRERAS
1019 HOUGH AVENUE
ADKINS TX 78101-9773 | 179. ESTATE OF GREGORIO PAZ
722 HOUGH AVENUE
ADKINS TX 78101-9710 |
| 170. VINCENTE & ANNA MARTINEZ
319 HARDING PL
SAN ANTONIO TX 78203-1811 | 180. HENRY A BAREFIELD
5405 DARLINGTON LN
AUSTIN TX 78723-4708 |

Table 5-1
Property Owners List (Continued)

- | | |
|--|---|
| 181. DANYKA T SRYGAR
7708 TRIPLE ACRES DR
CHINA GROVE TX 78263 | 191. MARY E & FRANCISCO VELA
9303 WEICHOLD RD
CONVERSE TX 78109-4291 |
| 182. SHELBY LEIGH VESELKA
6122 PLEASANT MEADOW
SAN ANTONIO TX 78222-3439 | 192. ERNESTO V BELLO
1030 HOUGH AVENUE
ADKINS TX 78101-3318 |
| 183. NORMA ALICIA RUIZ VELIZ
7918 FM 1346
SAN ANTONIO TX 78263 | 193. ROBT REV MILLER
135 MAGENDIE ST
SAN ANTONIO TX 78210-2545 |
| 184. CATALINA A AMAYA
92 VISTA RD
SAN ANTONIO TX 78210-3219 | 194. MERLIN E SUNDE
PO BOX 39621
SAN ANTONIO TX 78218-6621 |
| 185. JERRY K CROSS
906 HOUGH AVENUE
ADKINS TX 78101-3367 | 195. MARLA DEL RODLO SALINASDESORLA
13034 GEYSER PEAK
SAN ANTONIO TX 78253-6361 |
| 186. MEDINA PORFIRIO
11319 E LOOP 1604 S
SAN ANTONIO TX 78263-9689 | |
| 187. RICHARD D & CHERI A JESTER
10430 FM 1346
ADKINS TX 78101-3332 | |
| 188. JUAN MONTALVO
1006 HOUGH AVENUE
ADKINS TX 78101-3318 | |
| 189. ADRIANA R FREEMAN
12518 KAVA KNL
SAN ANTONIO TX 78253-5261 | |
| 190. MELISSA JEAN MEDELLIN &
MARGARET C LAQUE
7433 S LOOP 1604 W
VON ORMY TX 78073-4291 | |

INSERT CD WITH MAILING LABELS

6 AERIAL PHOTOGRAPH

An aerial photograph of the proposed TS site and surrounding area (minimum of 1-mile radius from the site) is presented on Figure I/II-6.1.

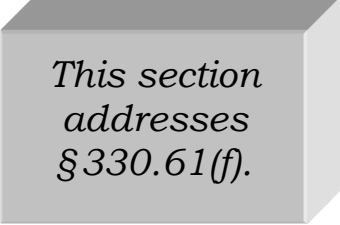

*This section
addresses
§330.61(f).*

0:\0601\12\TYPE V PERMIT APP\PARTS 1-II\CLEAN\FIG 6.1-AERIAL PHOTOGRAPH.dwg, mbahmani, 1:2

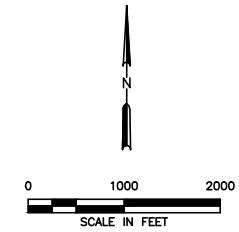

LEGEND

	1-MILE RADIUS
	PERMIT BOUNDARY
	PROPERTY BOUNDARY

NOTES:
 1. AERIAL PHOTOGRAPH PROVIDED BY GOOGLE EARTH DATED AUGUST 09, 2022.

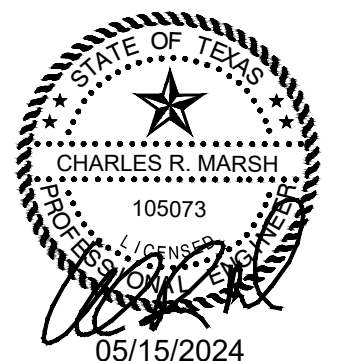

Tech. Complete App. - 063

<input type="checkbox"/> DRAFT <input checked="" type="checkbox"/> FOR PERMITTING PURPOSES ONLY <input type="checkbox"/> ISSUED FOR CONSTRUCTION	PREPARED FOR WASTE CONNECTIONS LONE STAR, INC.	TYPE V PERMIT APPLICATION AERIAL PHOTOGRAPH SAN ANTONIO TRANSFER STATION BEXAR COUNTY, TEXAS					
	DATE: 01/2024 FILE: 0601-012-11 CAD: FIG 6.1-AERIAL PHOTOGRAPH.DWG		DRAWN BY: RAA DESIGN BY: MB REVIEWED BY: CRM				
REVISIONS		WWW.WCGRP.COM					
<table border="1"> <thead> <tr> <th>NO.</th> <th>DATE</th> <th>DESCRIPTION</th> </tr> </thead> <tbody> <tr> <td>1</td> <td>05/2024</td> <td>PERMIT MODIFICATION</td> </tr> </tbody> </table>			NO.	DATE	DESCRIPTION	1	05/2024
NO.	DATE	DESCRIPTION					
1	05/2024	PERMIT MODIFICATION					
Weaver Consultants Group TBPE REGISTRATION NO. F-3727		FIGURE 1/II-6.1					

7 LAND USE

7.1 Character of Surrounding Land and Land Use

A land use evaluation was performed for the area within 1 mile of the San Antonio TS permit boundary. Land use information is summarized on the following maps.

This section addresses § 330.61(g), § 330.61(h), and § 305.45(a)(6)(B).

- Figure I/II-7.1 (Land Use Map – Aerial). This map highlights land use within a one-mile radius of the site on an aerial photograph.
- Figure I/II-7.2 (Cities within 5 Miles – Aerial). This map is used to show area cities within 5 miles and to summarize growth trends.

7.2 Location and Zoning

The San Antonio TS is located outside of the city limits of San Antonio, Texas. The facility's physical address is 10244 Farm to Market 1346, Bexar County, Texas 78101. The permit boundary is designated as OCL (Outside City Limits) in San Antonio's Zoning Map. Bexar County does not have zoning designations, so there is no zoning associated with the TS property. The nearest zoned property is located approximately 2.5 miles north of the TS site.

7.3 Surrounding Land Use

Land use within a 1-mile radius of the permit boundary is predominantly single family residential, agricultural, and transportation corridor. There are several residential neighborhoods scattered to the north, east, and west sides of the facility. The property located to the immediate west is commercial/industrial, to the east and north is single family residential, and to the south is undeveloped.

7.4 Growth Trends of the Nearest Community

The facility property is located outside of the city limit of San Antonio in the unincorporated area of Bexar County.

The growth trends for the Bexar County were assessed and are presented in Table 7-1. The population projections were taken from the Texas Water Development Board (TWDB) 2021 Regional Water Plan.

Table 7-1
Growth Trends
Average Annual Growth Rate

Community	2020-2030	2031-2040	2041-2050
Bexar County	1.30%	1.06%	0.92%

7.5 Proximity to Residences and Other Uses

The nearest residence is found approximately 48 feet northeast of the Permit boundary and approximately 180 feet from the TS structure. The nearest business (RDZ Paving) is located approximately 130 feet south of the TS boundary.

There are no known hospitals, lakes, or sites with exceptional aesthetic qualities located within a one-mile radius.

7.6 Land Use Conclusions

The use of this land as a transfer station represents a compatible land use for the following reasons.

- The site is designed to have minimal impact on the surrounding area.
- The roadways provide adequate access.
- The existing commercial/industrial use of the land is similar to that of the proposed transfer station.

7.7 Oil and Water Wells Within 500 Feet

According to a June 2023 review of the ERIS database, there are no oil or gas wells located within 500 feet of the TS site, and the nearest oil/gas is located over 1,300 feet west of the site.

A ½-mile water well search, which includes a review of records from the Texas Water Development Board (TWDB), Water Utility Database (WUD), Select Submitted Drillers Report Database Wells (SSDRD), United States Geological Survey (USGS) National Water Information System (NWIS), and TCEQ water wells, was conducted for the site by ERIS. The results of this search are contained in Appendix

I/II.B. According to the searched records, there are no water wells located within 500 feet of the property boundary, and the nearest water well is over 7,000 feet northeast of the site. A map indicating the identified well locations is provided as Figure I/II-4.2 in Section 4.

0:\0601\12\TYPE V PERMIT APP\PARTS 1-II\CLEAN\FIG 7.1-1 LAND USE MAP.dwg, mbahmani, 1:2

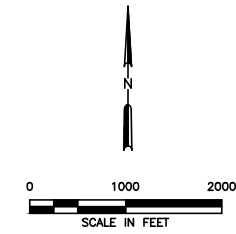

LEGEND

	PERMIT BOUNDARY
	PROPERTY BOUNDARY
	1-MILE RADIUS
R	RESIDENTIAL
IC	INDUSTRIAL/COMMERCIAL
AG	AGRICULTURAL/OPEN SPACE
	EXISTING STREAM

NOTES:

1. AERIAL PHOTOGRAPH PROVIDED BY GOOGLE EARTH DATED AUGUST 09, 2022.
2. LAND USE IS SHOWN ONLY WITHIN THE 1-MILE BOUNDARY.
3. SITE ACCESS ROADS WITHIN 1 MILE OF THE SITE INCLUDE FM 1346.
4. EXCEPT AS OTHERWISE SHOWN, LAND USE IS PREDOMINANTLY AGRICULTURAL, INDUSTRIAL/COMMERCIAL, AND RESIDENTIAL.
5. REFER TO FIGURE I/II-4.3 FOR INFORMATION REGARDING STRUCTURES AND INHABITABLE BUILDINGS WITHIN 500 FEET OF THE PERMIT BOUNDARY.
6. THERE ARE NO LAKES, AND SEVERAL SMALL PONDS WITHIN THE 1-MILE RADIUS.
7. ALL PAVED ROADS TO BE USED NORMALLY BY TRLC TO ACCESS THE FACILITY WITHIN THE 1-MILE RADIUS ARE EITHER ASPHALT OR CONCRETE.

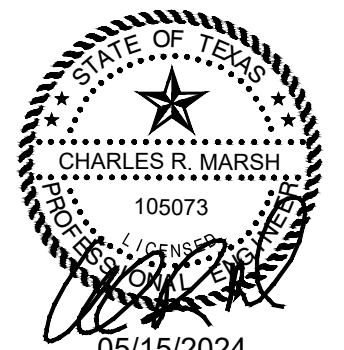

Tech. Complete App. - 067

<input type="checkbox"/> DRAFT <input checked="" type="checkbox"/> FOR PERMITTING PURPOSES ONLY <input type="checkbox"/> ISSUED FOR CONSTRUCTION	PREPARED FOR WASTE CONNECTIONS LONE STAR, INC.		TYPE V PERMIT APPLICATION LAND USE MAP SAN ANTONIO TRANSFER STATION BEXAR COUNTY, TEXAS					
	DATE: 01/2024 FILE: 0601-012-11 CAD: FIG 7.1-LAND USE MAP.DWG	DRAWN BY: RAA DESIGN BY: MB REVIEWED BY: CRM		REVISIONS <table border="1"> <thead> <tr> <th>NO.</th> <th>DATE</th> <th>DESCRIPTION</th> </tr> </thead> <tbody> <tr> <td>1</td> <td>05/2024</td> <td>PERMIT MODIFICATION</td> </tr> </tbody> </table>	NO.	DATE	DESCRIPTION	1
NO.	DATE	DESCRIPTION						
1	05/2024	PERMIT MODIFICATION						
Weaver Consultants Group TBPE REGISTRATION NO. F-3727			WWW.WCGRP.COM FIGURE I/II-7.1					

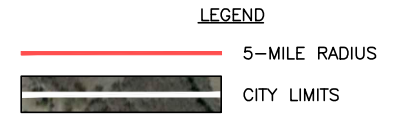
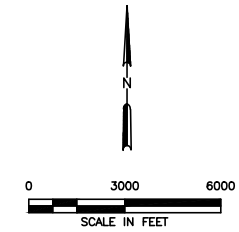
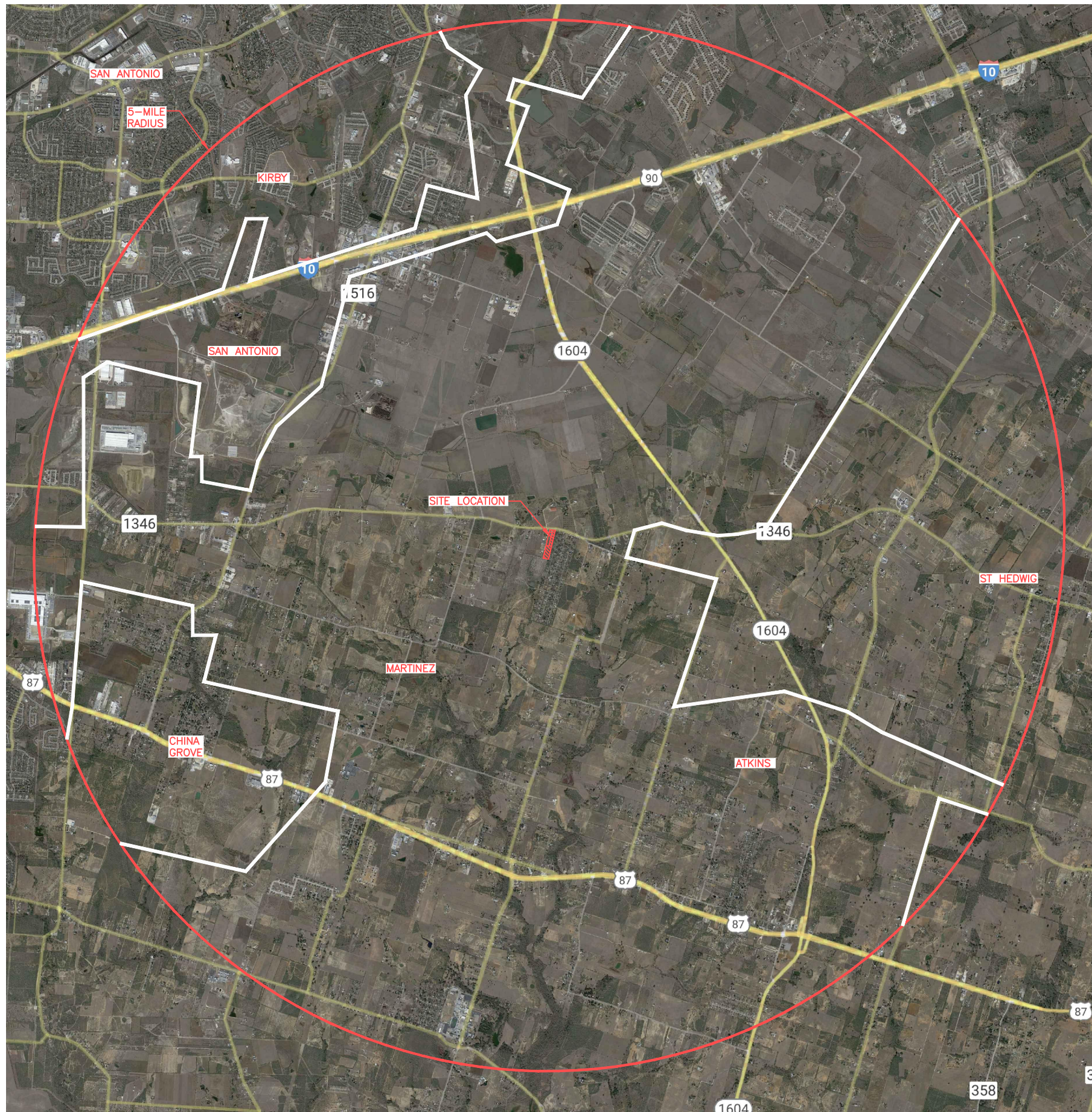

NOTES:

1. AERIAL PHOTOGRAPH PROVIDED BY GOOGLE EARTH DATED DECEMBER 16, 2020.
2. MARTINEZ AND ATKINS ARE UNINCORPORATED COMMUNITIES IN BEXAR COUNTY.



Tech. Complete App. - 068

<input type="checkbox"/> DRAFT <input checked="" type="checkbox"/> FOR PERMITTING PURPOSES ONLY <input type="checkbox"/> ISSUED FOR CONSTRUCTION	PREPARED FOR WASTE CONNECTIONS LONE STAR, INC.	TYPE V PERMIT APPLICATION CITIES WITHIN 5-MILE RADIUS SAN ANTONIO TRANSFER STATION BEXAR COUNTY, TEXAS									
DATE: 01/2024 FILE: 0601-012-11 CAD: FIG 7.2-CITIES WITHIN 5-MILES.DWG	DRAWN BY: RAA DESIGN BY: MB REVIEWED BY: CRM	<table border="1" style="width: 100%; border-collapse: collapse;"> <thead> <tr> <th colspan="3">REVISIONS</th> </tr> <tr> <th>NO.</th> <th>DATE</th> <th>DESCRIPTION</th> </tr> </thead> <tbody> <tr> <td style="text-align: center;">1</td> <td style="text-align: center;">05/2024</td> <td style="text-align: center;">PERMIT MODIFICATION</td> </tr> </tbody> </table>	REVISIONS			NO.	DATE	DESCRIPTION	1	05/2024	PERMIT MODIFICATION
REVISIONS											
NO.	DATE	DESCRIPTION									
1	05/2024	PERMIT MODIFICATION									
Weaver Consultants Group TBPE REGISTRATION NO. F-3727		WWW.WCGRP.COM FIGURE 1/II-7.2									

8 TRANSPORTATION

8.1 Traffic Information

The proposed San Antonio TS will be located on the south side of FM 1346, in Bexar County, Texas. The entrance to the proposed TS connects directly to FM 1346 Road. Vehicles bound for the San Antonio TS will access the site using FM 1346. Waste collection vehicles will enter the site by travelling 3.7 miles south of the intersection of Interstate 10 and FM 1604 and then 1.5 miles west of the intersection of FM 1604 and FM 1346. Other roads may be periodically used by collection vehicles to serve residences and businesses located along or near these roadways; however, these roads are not main access roads that collection vehicles will routinely use to access the site.

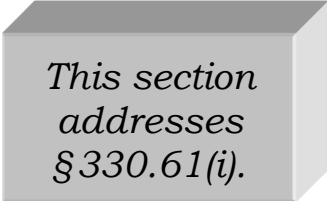

*This section
addresses
§ 330.61(i).*

The San Antonio Transfer Station has two existing driveways connecting directly to FM 1346. The east driveway is proposed to be widened and used as the main facility entrance. The west driveway will be utilized by employees and visitors only. FM 1346 is suitable to handle the projected traffic load associated with the TS. FM 1346 is a two-lane, two-way asphalt road with a speed limit of 55 miles per hour.

Consistent with Title 30 TAC §330.61(i)(3), a traffic study for the TS was completed and submitted to TxDOT on August 18, 2023. The traffic study concluded that the existing roads and intersections will provide adequate access to the site. Per the recommendations of TxDOT FM 1346 will be widened to include auxiliary lanes to access the transfer station. TxDOT coordination is included in Appendix I/IIA (refer to the TxDOT tab).

8.2 Airport Impact

No public-use airports exist within six miles of the San Antonio TS. The closest public-use airport to the facility is the Stinson – Mission Municipal Airport, which is located approximately 12 miles southwest of the site, as shown on Figure I/II-8.1. San Antonio International Airport is also located 13 miles northwest of the facility as shown in Figure I/II-8.1. Randolph Air Force base is located approximately 6 miles from the facility. In accordance with Title 30 TAC §330.61(i)(5), an airport impact evaluation of the facility is required only for landfill units and landfill mining operations and thus is not required for a transfer station.

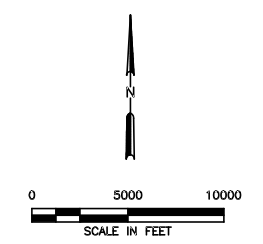
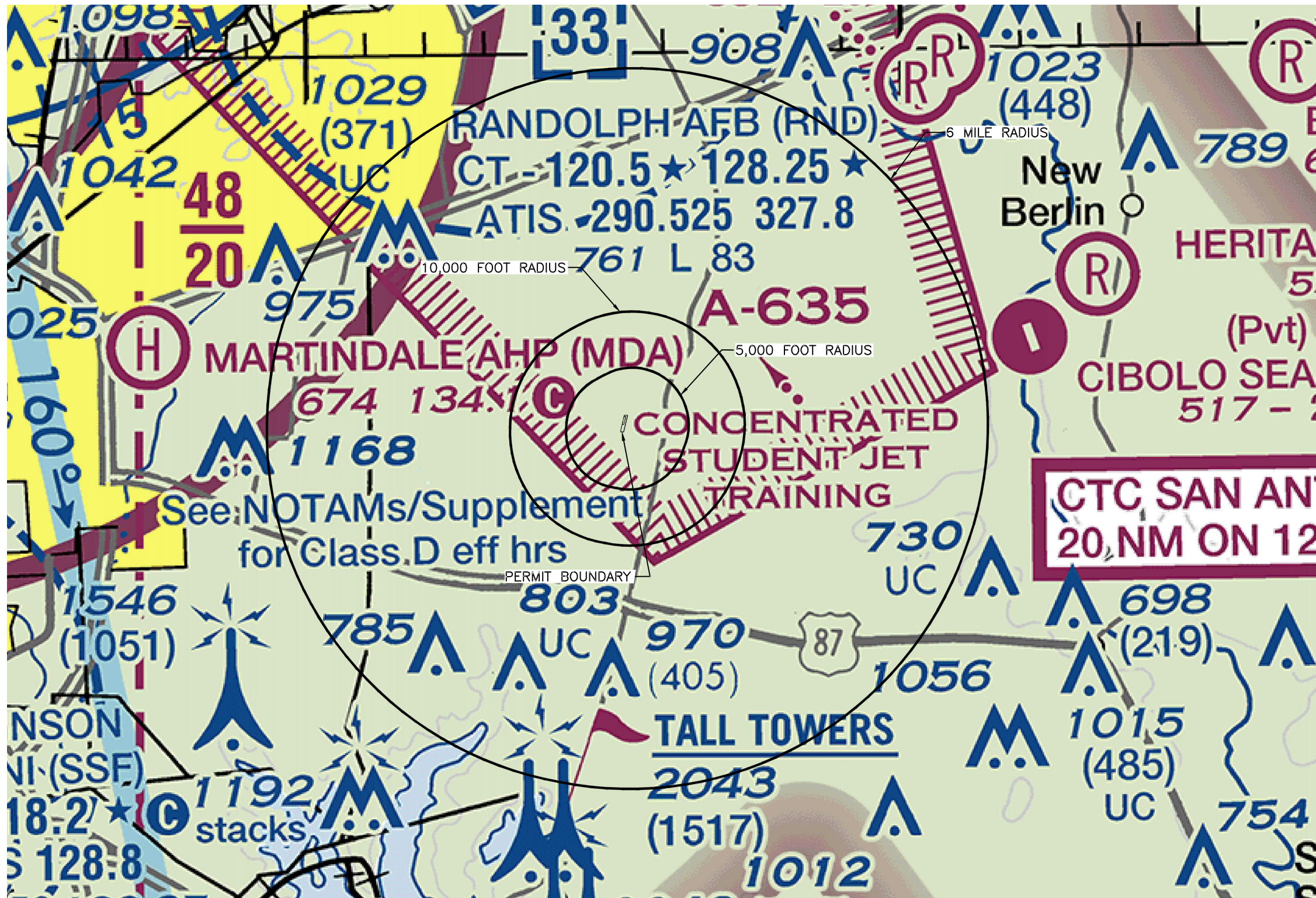

LEGEND

AIRPORTS

- Other than hard-surfaced runways
- Hard-surfaced runways 1500 ft. to 8069 ft. in length
- Hard-surfaced runways greater than 8069 ft. or some multiple runways less than 8069 ft.
- Open dot within hard-surfaced runway configuration indicates approximate VOR, VOR-DME, DME or VORTAC location.
- All recognizable hard-surfaced runways, including those closed, are shown for visual identification. Airports may be public or private.

ADDITIONAL AIRPORT INFORMATION

- Private "(Pvt)" - Non-public use having landmark value
- Military - Other than hard-surfaced; all military airports are identified by abbreviations AFB, NAS, AAF, etc.
- Heliport Selected
- Unverified
- Abandoned - paved having landmark value, 3000 ft. or greater
- Ultralight Flight Park Selected

Fuel availability indicated by use of flick marks around basic airport symbol. Consult Supplement for details and availability at airports with hard-surfaced runways greater than 8069 ft.

★ Rotating airport beacon in operation Sunset to Sunrise

OBJECTIONABLE - Airport may adversely affect airspace use.

***Alert Area and Military Operations Area (MOA)**
(may be lit or unlit)

OBSTRUCTIONS
(may be lit or unlit)

- 1000 ft and higher AGL
- Above 200 ft & below 1000 ft AGL (above 299 ft AGL in urban area)
- Obstruction with high-intensity lights; may operate part-time
- Wind Turbine Farm
- Group Obstruction
- Wind Turbine Farm
- Elevation of the top above mean sea level
- Height above ground
- Under construction or reported position and elevation unverified
- NOTICE: Guy wires may extend outward from structures.

TOPOGRAPHIC INFORMATION

- Power Transmission Line
- Aerial Cable
- Lookout Tower
- Mountain Pass
- Pass symbol does not indicate a recommended route or direction of flight and pass elevation does not indicate a recommended clearance altitude. Hazardous flight conditions may exist within and near mountain passes.

- NOTES:**
- THIS MAP REPRODUCED FROM THE FAA SAN ANTONIO SECTIONAL AERONAUTICAL CHART EDITION DATED JUNE 15, 2023.
 - THE NEAREST AIRPORTS TO THE PERMIT BOUNDARY ARE STINSON-MISSION MUNICIPAL AIRPORT LOCATED 12 MILES SOUTHWEST, AND SAN ANTONIO INTERNATIONAL LOCATED 13 MILES NORTHWEST.

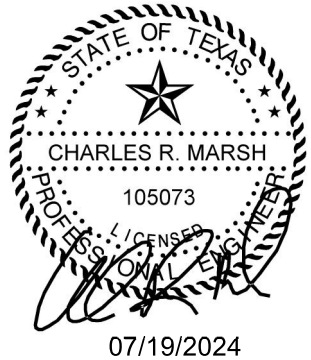

<input type="checkbox"/> DRAFT <input checked="" type="checkbox"/> FOR INFORMATION PURPOSES ONLY <input type="checkbox"/> ISSUED FOR CONSTRUCTION	PREPARED FOR WASTE CONNECTIONS LONE STAR, INC.		TYPE V PERMIT APPLICATION AREA AIRPORTS SAN ANTONIO TRANSFER STATION BEJAR COUNTY, TEXAS					
	DATE: 01/2024 FILE: 0601-012-11 CAD: FIG 1/II-8.1-AREA AIRPORTS.DWG			REVISIONS <table border="1"> <thead> <tr> <th>NO.</th> <th>DATE</th> <th>DESCRIPTION</th> </tr> </thead> <tbody> <tr> <td>1</td> <td>05/2024</td> <td>PERMIT MODIFICATION</td> </tr> </tbody> </table>	NO.	DATE	DESCRIPTION	1
NO.	DATE	DESCRIPTION						
1	05/2024	PERMIT MODIFICATION						
Weaver Consultants Group TBPE REGISTRATION NO. F-3727			WWW.WCGRP.COM FIGURE 1/II-8.1					

Tech. Complete App. - 070

C:\0601\12\TYPE V PERMIT APP\PARTS 1-IN\CLEAN (07-2024)\FIG 8.1-AIRPORT MAP.dwg - Farrington, L2

9 GENERAL GEOLOGY AND SOILS STATEMENT

The U.S. Department of Agriculture's Web Soil Survey dated June 2023 for San Antonio County, Texas indicates the soils beneath the proposed TS consist of two different units; Laparita Clay Loam and San Antonio Clay Loam.

*This section
addresses
§330.61(j).*

The Laparita Clay Loam makes up approximately 17% of the Property's soil. The Laparita Clay Loam is well drained with 1 to 3 percent slopes. The unit has moderately high runoff potential when thoroughly wet, since water transmission through the soil is somewhat restricted. The typical soil profile is clay loam, sand clay, and clay from 0 to 60 inches. These soils are clayey residuum derived from weathered shale.

San Antonio Clay Loam makes up approximately 83% of the Property's soils. The San Antonio Clay Loam is well drained with 1 to 3 percent slopes. The unit has moderately high runoff potential when thoroughly wet, since water transmission through the soil is somewhat restricted. The typical soil profile is clay loam, clay, and clay loam from 0 to 60 inches. These soils are derived from loamy alluvium of Quaternary age.

According to the Bureau of Economic Geology (BEG) Geologic Atlas of Texas San Antonio Sheet (1983), the site is located on the outcrop of the Eocene-age Wilcox Group. The Wilcox Group is of littoral and deltaic deposition and composed primarily of sand, interbedded with clay, silt, and lignite beds (Sellards, 1990). The maximum regional thickness of the Wilcox Group is about 1,000 feet in Bexar county (Manford, 1959). The Wilcox Group can be divided into three component formations which include, from youngest to oldest, the Calvert Bluff Formation, the Simsboro Formation, and the Hooper Formation (BEG, 1983). The Wilcox Group contains the uppermost aquifer beneath the facility.

REFERENCES

Bureau of Economic Geology (BEG), 1983, Geologic Atlas of Texas, San Antonio Sheet, University of Texas at Austin, Scale 1:250,000 (Text by V.E. Barnes).

Sellards, E. H., Adkins, W. S., and Plummer, F. B., 1990, The Geology of Texas, Volume 1: Stratigraphy, Bureau of Economic Geology, The University of Texas at Austin, Bulletin 3232.

Durwood Manford, Dixon R. M., Dent O. F., 1959, Groundwater Geology of Bexar County, Texas, Texas Board of Water Engineers, Bulletin 5911.

10 GROUNDWATER AND SURFACE WATER STATEMENT

10.1 Groundwater Statement

According to Texas Water Development Board (TWDB) the uppermost aquifer located beneath the site is the Carrizo-Wilcox Aquifer. The Carrizo-Wilcox Aquifer is a major aquifer of Texas extending from Louisiana to the border of Mexico in a wide band adjacent to and northwest of the Gulf Coast (TWDB). The Carrizo-Wilcox Aquifer consists of the Wilcox Group and the overlying Carrizo Formation. The Carrizo Formation is absent beneath the facility. According to the TWDB groundwater availability model (GAM) for the Central Portion of the Carrizo-Wilcox, Queen City, and Sparta Aquifers (TWDB, 2018), and regional water well data groundwater is observed about 100-feet or greater below ground surface in the facility area and flows to the South-Southeast in the direction of formational dip. According to the searched records, there is no water wells located within 500 feet of the property boundary and the nearest water well is over 1,800 feet southwest of the site.

*This section
addresses
§ 330.61(k).*

10.2 Surface Water Statement

The proposed TS is situated within the San Antonio Basin, characterized by its relatively modest size and average annual watershed yield. Adjacent to the facility, there are several creeks. Notably, Martinez Creek can be found 0.7 miles north of the facility, flowing in an eastward direction from its western source. In the southeastern and southern vicinity of the facility, Chupaderas Creek meanders, nourished by several tributaries, and it flows from the northeast towards the south. Predominately, the property's terrain directs its drainage eastwards. Ultimately, all surface runoff in the area converges in a southerly direction through the tributaries of Chupaderas Creek, culminating in its arrival at Calaveras Lake

The TS has been designed to achieve the following goals:

1. Prevent the discharge of solid waste or pollutants adjacent to or into waters in the state of Texas.
2. Prevent a discharge of pollutants into waters of the United States.
3. Prevent a discharge of nonpoint source pollution to waters of the United States.

The TS will consist of a steel structure with a reinforced concrete slab. Drainage from the facility property is designed to prevent erosion over areas associated with the registration boundary and avoid the offsite discharge of waste. Surface water drainage in and around the facility will be controlled to prevent surface water running onto, into, and from the TS structure.

The TS will operate in such a manner as to prevent discharge of pollutants into waters of the state of United States as defined by the Texas Water Code and the Federal Clean Water Act. The site is subject to the TCEQ's stormwater permit requirements and will operate under the TPDES General Permit for Stormwater Discharges, under Standard Industrial Code (SIC) 4212 (Transportation and Warehousing).

Once the site has obtained the TCEQ approval, the site will obtain a TPDES authorization, maintain compliance with the TPDES requirements, and will operate in accordance with a site-specific Storm Water Pollution Prevention Plan (SWPPP) for the operation.

REFERENCES

Texas Water Development Board (TWDB), 2024, Submitted Driller Report Database, online at: <https://www.twdb.texas.gov/groundwater/data/drillersdb.asp>

Young, S., Jigmond, M., Jones, T., and Ewing T., 2018, Groundwater availability model for the Central Portion of the Sparta, Queen City, and Carrizo-Wilcox Aquifers, Final Report, Texas Water Development Board.

11 FLOODPLAIN AND WETLANDS STATEMENT

11.1 Floodplain Statement

As shown on Figure I/II-11.1, the TS permit boundary is not located within the 100-year floodplain. The nearest FEMA defined floodplain is located 1,929 feet north of the TS permit boundary.

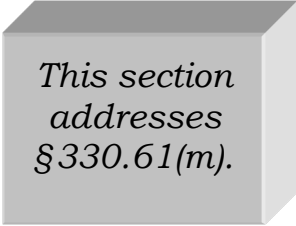

*This section
addresses
§ 330.61(m).*

11.2 Wetlands Statement

11.2.1 Regulatory Background

WCG performed a general determination of “Waters of the US” (including wetlands for the TS). The jurisdictional determination consisted of a pre-field literature review and a site assessment. A copy of the WCG report is included in Appendix I/IIC. Based on the information included in WCG’s report, no waters of the US, including wetlands, are located on the TS site.

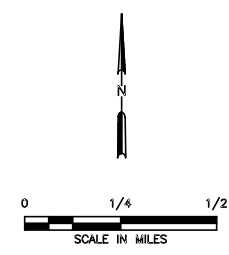

LEGEND

<p>----- PERMIT BOUNDARY</p> <p>----- PROPERTY BOUNDARY</p>	
SPECIAL FLOOD HAZARD AREAS	<p>Without Base Flood Elevation (BFE) Zone A, U, AB, B</p>
	<p>With BFE or Depth Zone AE, AO, AH, VE, AR</p>
	<p>Regulatory Floodway</p>
OTHER AREAS OF FLOOD HAZARD	<p>0.2% Annual Chance Flood Hazard, Areas of 1% annual chance flood with average depth less than one foot or with drainage areas of less than one square mile Zone X</p>
	<p>Future Conditions 1% Annual Chance Flood Hazard Zone X</p>
	<p>Area with Reduced Flood Risk due to Levee See Notes Zone X</p>
	<p>Area with Flood Risk due to Levee Zone D</p>
OTHER AREAS	<p>NO SCREEN Area of Minimal Flood Hazard Zone X</p>
	<p>Effective LOMRs</p>
	<p>Area of Undetermined Flood Hazard Zone D</p>
GENERAL STRUCTURES	<p>Channel, Culvert, or Storm Sewer</p>
	<p>Levee, Dike, or Floodwall</p>
OTHER FEATURES	<p>20.2 Cross Sections with 1% Annual Chance</p>
	<p>17.5 Water Surface Elevation</p>
	<p>Coastal Transect</p>
	<p>Coastal Transect Baseline</p>
	<p>Profile Baseline</p>
	<p>Hydrographic Feature</p>
	<p>Base Flood Elevation Line (BFE)</p>
	<p>Limit of Study</p>
	<p>Jurisdiction Boundary</p>

NOTES:

- FLOODPLAIN INFORMATION PROVIDED BY FEMA FIRM PANEL 48029C0445G FOR BEXAR COUNTY, TEXAS AND INCORPORATED AREAS DATED SEPTEMBER 29, 2010.



07/19/2024
Tech. Complete App. - 077

<input type="checkbox"/> DRAFT <input checked="" type="checkbox"/> FOR PERMITTING PURPOSES ONLY <input type="checkbox"/> ISSUED FOR CONSTRUCTION		PREPARED FOR WASTE CONNECTIONS LONE STAR, INC.		TYPE V PERMIT APPLICATION FLOOD INSURANCE RATE MAP							
DATE: 01/2024 FILE: 0601-012-11 CAD: FIG 11.1-FIRM.DWG		DRAWN BY: RAA DESIGN BY: MB REVIEWED BY: CRM		REVISIONS							
		<table border="1"> <thead> <tr> <th>NO.</th> <th>DATE</th> <th>DESCRIPTION</th> </tr> </thead> <tbody> <tr> <td>1</td> <td>05/2024</td> <td>PERMIT MODIFICATION</td> </tr> </tbody> </table>		NO.	DATE	DESCRIPTION	1	05/2024	PERMIT MODIFICATION	SAN ANTONIO TRANSFER STATION BEXAR COUNTY, TEXAS	
NO.	DATE	DESCRIPTION									
1	05/2024	PERMIT MODIFICATION									
Weaver Consultants Group TBPE REGISTRATION NO. F-3727		WWW.WCGRP.COM		FIGURE 1/II-11.1							

12 PROTECTION OF ENDANGERED SPECIES

WCG conducted a threatened and endangered survey for the TS project property to determine whether the project would have an adverse effect on threatened and endangered species and/or their habitat. Based on the information included in the WCG report, the proposed construction of the TS will not likely have an adverse effect on federal or state listed threatened or endangered species. Therefore, this facility will be in compliance with all applicable federal, state and local laws regarding threatened and endangered species. A copy of the WCG report is included in Appendix I/IID.

13 LEGAL DESCRIPTION

A legal description of the 7.51-acre permit boundary is included on the following pages. The current ownership record for the property may be found in Document 20230032599 of the Official Public Records of Bexar County, Texas.

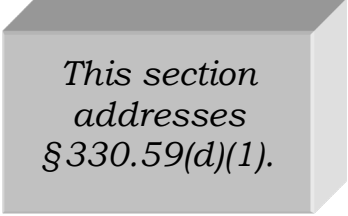

*This section
addresses
§330.59(d)(1).*

EXHIBIT "A"
REGISTRATION BOUNDARY LEGAL DESCRIPTION
327,291 SQUARE FEET (7.513 ACRES) TRACT OUT OF THE
DEMACI DE LAS REYES SURVEY NO. 26, ABSTRACT NO. 618
& THE O.H. PETERS SURVEY NO. 138, ABSTRACT NO. 596,
BEXAR COUNTY, TEXAS

BEING A 327,291 SQUARE FOOT (7.513 ACRE) TRACT OF LAND SITUATED IN THE DEMACI DE LAS REYES SURVEY NO. 26, ABSTRACT NO. 618, AND THE O.H. PETERS SURVEY NO. 138, ASBTRACT NO. 596, BEXAR COUNTY, TEXAS, AND BEING A PORTION OF A CALLED 10.017 ACRE TRACT OF LAND DESCRIBED IN A GENERAL WARRANTY DEED TO WASTE CONNECTIONS LONE STAR, INC., RECORDED IN DOCUMENT NO. 20230032599, OFFICIAL PUBLIC RECORDS, BEXAR COUNTY, TEXAS (O.P.R.B.C.T.), AND BEING MORE PARTICULARLY DESCRIBED AS FOLLOWS:

BEGINNING AT A 1 INCH PIPE FOUND IN THE WEST LINE OF BLOCK 3, EASTVIEW TERRACE, AN ADDITION TO BEXAR COUNTY, TEXAS, ACCORDING TO THE PLAT RECORDED IN VOL. 3850, PG. 224, PLAT RECORDS, BEXAR COUNTY, TEXAS (P.R.B.C.T.), FOR THE NORTHEAST CORNER OF A CALLED 18.742 ACRE TRACT OF LAND DESCRIBED IN A WARRANTY DEED WITH VENDOR'S LIEN TO BENNIE L. MITCHELL, RECORDED IN VOL. 1741, PG. 514, O.P.R.B.C.T., FOR THE SOUTHEAST CORNER OF SAID 10.017 ACRE TRACT AND SAID 7.513 ACRE TRACT, AND HAVING SURFACE COORDINATES OF NORTHING: 13,701,462.92, EASTING: 2,196,110.94 RELATIVE TO THE TEXAS COORDINATE SYSTEM OF 1983, SOUTH CENTRAL ZONE, NAD83(2011) EPOCH 2010.00, SAID SURFACE COORDINATES HAVING BEEN DERIVED BY DIVIDING BY THE COMBINED PROJECT SCALE FACTOR OF 0.999870016 FROM AN ORIGIN OF 0,0;

THENCE NORTH 81°59'04" WEST (CALLED NORTH 81°46'27" WEST), ALONG THE NORTH LINE OF SAID 18.742 ACRE TRACT AND THE SOUTH LINE OF SAID 10.017 ACRE TRACT, A DISTANCE OF 287.18 FEET (CALLED 287.17 FEET) TO A 1/2 INCH IRON ROD FOUND FOR THE SOUTHWEST CORNER OF SAID 10.017 ACRE TRACT AND SAID 7.513 ACRE TRACT AND FOR THE SOUTHEAST CORNER OF LOT 6, BLOCK 1, EAST CENTRAL ACRES SUBDIVISION, AN ADDITION TO BEXAR COUNTY, TEXAS ACCORDING TO THE PLAT RECORDED IN VOL. 9541, PG. 82, P.R.B.C.T., AND A CALLED 5.7450 ACRE TRACT OF LAND RECORDED IN A WARRANTY DEED WITH VENDOR'S LIEN TO JASON E AND KAREN D KNOWLES, RECORDED IN VOL. 9354, PG. 1910, O.P.R.B.C.T.;

THENCE NORTH 13°21'43" EAST (CALLED NORTH 13°34'20" EAST) ALONG THE EAST LINE OF SAID 5.7450 ACRE TRACT AND SAID LOT 6, BLOCK 1 AND THE WEST LINE OF SAID 10.017 ACRE TRACT, A DISTANCE OF 682.85 FEET TO A 1/2 INCH IRON ROD WITH YELLOW CAP STAMPED "WCG" SET FOR THE SOUTHERLY NORTHWEST CORNER OF SAID 7.513 ACRE TRACT;

THENCE OVER AND ACROSS SAID 10.017 ACRE TRACT THE FOLLOWING COURSES AND DISTANCES:

SOUTH 76°37'07" EAST, A DISTANCE OF 145.40 FEET TO A 1/2" IRON ROD WITH YELLOW CAP STAMPED "WCG" SET FOR AN INTERIOR CORNER OF SAID 7.513 ACRE TRACT;

NORTH 13°22'53" EAST, A DISTANCE OF 476.41 FEET TO A 1/2" IRON ROD WITH YELLOW CAP STAMPED "WCG" SET FOR AN INTERIOR CORNER OF SAID 7.513 ACRE TRACT;

NORTH 56°32'21" EAST, A DISTANCE OF 17.52 FEET TO A 1/2" IRON ROD WITH YELLOW CAP STAMPED "WCG" SET FOR AN INTERIOR CORNER OF SAID 7.513 ACRE TRACT;

NORTH 13°21'43" EAST, A DISTANCE OF 240.00 FEET TO A 1/2" IRON ROD WITH YELLOW CAP STAMPED "WCG" SET FOR AN INTERIOR CORNER OF SAID 7.513 ACRE TRACT;

NORTH 76°38'16" WEST, A DISTANCE OF 157.55 FEET TO A 1/2" IRON ROD WITH YELLOW CAP STAMPED "WCG" SET IN THE EAST LINE OF SAID 5.7450 ACRE TRACT AND SAID LOT 6, BLOCK 1, AND THE WEST LINE OF SAID 10.017 ACRE TRACT FOR THE NORTHERLY SOUTHWEST CORNER OF SAID 7.513 ACRE TRACT;

THENCE NORTH 13°21'43" EAST (CALLED NORTH 13°34'20" EAST), ALONG THE EAST LINE OF SAID 5.7450 ACRE TRACT AND SAID LOT 6, BLOCK 1 AND THE WEST LINE OF SAID 10.017 ACRE TRACT, A DISTANCE OF 94.55 FEET TO A 1/2 INCH IRON ROD FOUND IN THE SOUTH RIGHT-OF-WAY LINE OF FM 1346 (80 FOOT RIGHT-OF-WAY ALSO KNOWN AS ST. HEDWIG ROAD), FOR THE NORTHEAST CORNER OF SAID EAST CENTRAL ACRES SUBDIVISION, FOR THE NORTHWEST CORNER OF SAID 10.017 ACRE TRACT AND SAID 7.513 ACRE TRACT, FOR THE BEGINNING OF A NON-TANGENT CURVE TO THE RIGHT, AND HAVING SURFACE COORDINATES OF NORTHING: 13,702,968.60, EASTING: 2,196,175.14, RELATIVE TO THE TEXAS COORDINATE SYSTEM OF 1983, SOUTH CENTRAL ZONE, NAD83(2011) EPOCH 2010.00, SAID SURFACE COORDINATES HAVING BEEN DERIVED BY DIVIDING BY THE COMBINED PROJECT SCALE FACTOR OF 0.999870016 FROM AN ORIGIN OF 0,0;

THENCE EASTERLY, ALONG THE SOUTH RIGHT-OF-WAY LINE OF SAID FM 1346, THE NORTH LINE OF SAID 10.017 ACRE TRACT, AND ALONG SAID NON-TANGENT CURVE TO THE RIGHT, HAVING A RADIUS OF 2,824.93 FEET, A DELTA ANGLE OF 5°55'48", WITH A CHORD THAT BEARS SOUTH 88°04'07" EAST (CALLED SOUTH 87°51'32" WEST) A CHORD DISTANCE OF 292.25 FEET, FOR AN ARC DISTANCE OF 292.38 FEET TO A 1/2" IRON ROD WITH YELLOW CAP STAMPED "WCG" SET FOR THE NORTHEAST CORNER OF SAID 10.017 ACRE TRACT AND SAID 7.513 ACRE TRACT AND FOR THE NORTHWEST CORNER OF LOT 1, BLOCK 1, OF SAID EASTVIEW TERRACE;

THENCE SOUTH 13°22'53" WEST (CALLED SOUTH 13°35'30" WEST), ALONG THE EAST LINE SAID 10.017 ACRE TRACT AND THE WEST LINE OF SAID EASTVIEW TERRACE, A DISTANCE OF 1537.70 FEET TO THE **POINT OF BEGINNING** AND CONTAINING **327,291 SQUARE FEET (7.513 ACRES)**, MORE OR LESS.

SURVEY NOTES:

1. BASIS OF BEARINGS: GRID NORTH, RELATIVE TO THE TEXAS COORDINATE SYSTEM OF 1983, NORTH AMERICAN DATUM OF 1983(2011) [EPOCH 2010.00], SOUTH CENTRAL ZONE, BASED ON REAL TIME KINEMATIC OBSERVATIONS UTILIZING ALLTERRA'S RTKNET VRS NETWORK. COORDINATES AND DISTANCES SHOWN HEREON HAVE BEEN SCALED TO SURFACE. TO CONVERT TO GRID, MULTIPLY BY THE COMBINED PROJECT SCALE FACTOR OF 0.999870016 FROM AN ORIGIN OF 0,0. ALL UNITS ARE IN U.S. SURVEY FEET.
2. THIS SURVEY IS BASED ON FIELD OBSERVATIONS COMPLETED DECEMBER 30, 2022, AND JUNE 19, 2023. FOUND AND SET MONUMENTS SHOWN HEREON WERE IN PLACE AT THE TIME OF THE FIELD SURVEY.
3. THIS SURVEY WAS PREPARED FOR PERMITTING PURPOSES ONLY AND NO IMPROVEMENTS ARE SHOWN. THIS SURVEY HAS BEEN PREPARED WITH THE BENEFIT OF A TITLE COMMITMENT PROVIDED BY CHICAGO TITLE INSURANCE COMPANY GF NO. SCT-48-4300112207145 WITH AN EFFECTIVE DATE OF JANUARY 18, 2023, ISSUED JANUARY 24, 2023.
4. A SURVEY MAP OF EVEN DATE ACCOMPANIES THIS DESCRIPTION.

Weaver Consultants Group
6420 Southwest Blvd | Suite 206
Fort Worth, TX 76109
817-735-9770
TBPLS REG# No. 10095400
TBPE REG# F- 3727

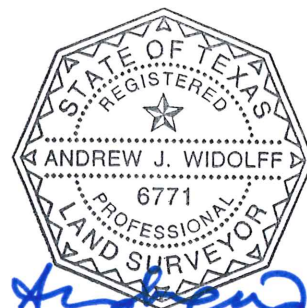

Andrew J. Widolff
9.28.23
Andrew J. Widolff RPLS No. 6771

SOURCE BENCHMARK

NGS BENCHMARK P.I.D. G832, ABOUT 1.6 MILES NORTH ALONG STUART ROAD FROM THE CROSS ROADS (U.S. 87 AND STUART ROAD) AT SAYERS, BEXAR COUNTY, TO AN OLD RAILROAD GRADE AND CROSS ROADS (MACAWAY AND STUART). BENCH MARK IS 98 FEET WEST OF THE CENTERLINE OF STUART ROAD, 29 FEET NORTH OF THE CENTERLINE OF MACAWAY ROAD, AND 31 FEET SOUTH OF THE CENTERLINE OF THE OLD RAILROAD GRADE. A STANDARD DISK STAMPED "G832 1934."

G832 ELEVATION (NAVD88)=602.4'

Site Control Table				
Point #	Northing	Easting	Elevation	Description
100	13702909.33	2196336.013	641.80	1/2" IRON ROD W/ RED CAP "WCG CONTROL"
101	13702920.46	2196162.338	643.43	1/2" IRON ROD W/ RED CAP "WCG CONTROL"
102	13702354.48	2196183.029	639.37	1/2" IRON ROD W/ RED CAP "WCG CONTROL"
103	13702542.19	2196058.117	642.29	1/2" IRON ROD W/ RED CAP "WCG CONTROL"

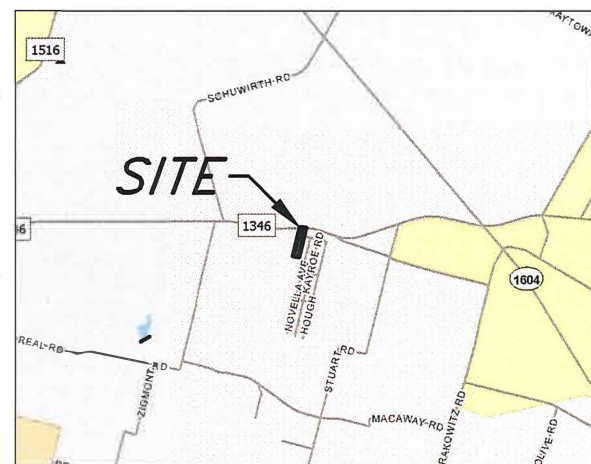

VICINITY MAP NOT TO SCALE

KELLY CHARLES MCBEE & ERIN MCBEE
CALLED 15.241 ACRES
DOC. NO. 20100098412
D.R.B.C.T.

EUSTAQUIO VARELA
CALLED 90.31 ACRES
DOC. NO. 20140140625
D.R.B.C.T.

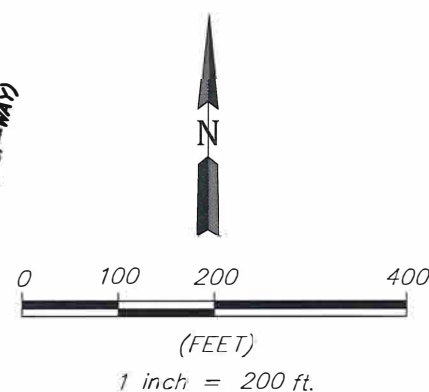
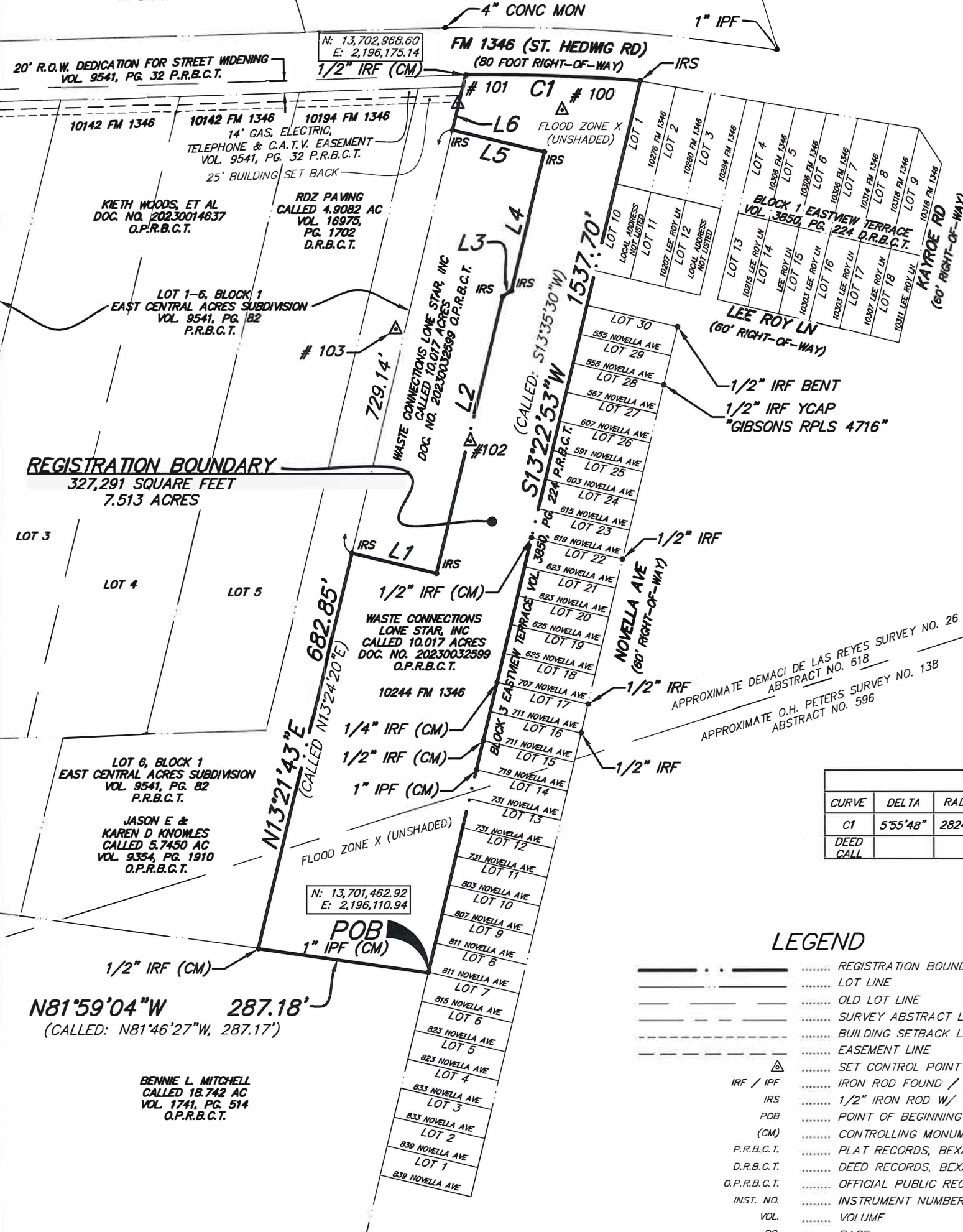

LINE TABLE		
LINE	BEARING	LENGTH
L1	S76°37'07"E	145.40'
L2	N13°22'53"E	476.41'
L3	N56°32'21"E	17.52'
L4	N13°21'43"E	240.00'
L5	N76°38'16"W	157.55'
L6	N13°21'43"E	94.55'
L6	(CALLED N13°24'20"E)	

CURVE TABLE					
CURVE	DELTA	RADIUS	LENGTH	CH. BRG.	CHORD
C1	5°55'48"	2824.93'	292.38'	S88°04'07"E	292.25'
DEED CALL				S87°51'32"W	

LEGEND

- REGISTRATION BOUNDARY LINE (BY THIS SURVEY)
- LOT LINE
- OLD LOT LINE
- SURVEY ABSTRACT LINE
- BUILDING SETBACK LINE
- EASEMENT LINE
- SET CONTROL POINT
- IRF / IPF IRON ROD FOUND / IRON PIPE FOUND
- IRS 1/2" IRON ROD W/ YELLOW CAP STAMPED "WCG" SET
- POB POINT OF BEGINNING
- (CM) CONTROLLING MONUMENT
- P.R.B.C.T. PLAT RECORDS, BEXAR COUNTY, TX
- D.R.B.C.T. DEED RECORDS, BEXAR COUNTY, TX
- O.P.R.B.C.T. OFFICIAL PUBLIC RECORDS, BEXAR COUNTY, TX
- INST. NO. INSTRUMENT NUMBER
- VOL. VOLUME
- PG. PAGE

SURVEY NOTES

- BASIS OF BEARINGS: GRID NORTH, RELATIVE TO THE TEXAS COORDINATE SYSTEM OF 1983, NORTH AMERICAN DATUM OF 1983(2011)[EPOCH 2010.00] SOUTH CENTRAL ZONE, BASED ON REAL TIME KINEMATIC OBSERVATIONS UTILIZING ALLTERRA'S RTKNET VRS NETWORK. COORDINATES AND DISTANCES SHOWN HEREON HAVE BEEN SCALED TO SURFACE. TO CONVERT TO GRID, MULTIPLY BY THE COMBINED PROJECT SCALE FACTOR OF 0.999870016 FROM AN ORIGIN OF 0,0. ALL UNITS ARE IN U.S. SURVEY FEET.
- ELEVATIONS SHOWN HEREON ARE RELATIVE TO THE NORTH AMERICAN VERTICAL DATUM OF 1988 (NAVD88) AS ADJUSTED TO THE SOURCE BENCHMARK DESCRIBED HEREON.
- THIS SURVEY IS BASED ON FIELD OBSERVATIONS COMPLETED DECEMBER 30, 2022 AND JUNE 19, 2023. FOUND AND SET MONUMENTS SHOWN HEREON WERE IN PLACE AT THE TIME OF THE FIELD SURVEY.
- THIS SURVEY WAS PREPARED FOR PERMITTING PURPOSES ONLY AND NO IMPROVEMENTS ARE SHOWN. THIS SURVEY HAS BEEN PREPARED WITH THE BENEFIT OF A TITLE COMMITMENT PROVIDED BY CHICAGO TITLE INSURANCE COMPANY OF NO. SCT-48-4300112207145 WITH AN EFFECTIVE DATE OF JANUARY 18, 2023, ISSUED JANUARY 24, 2023.
- THE SUBJECT TRACT IS DEPICTED WITHIN UNSHADED ZONE X AS SHOWN ON FLOOD INSURANCE RATE MAP NUMBER 48029C0445G, DATED SEPTEMBER 29, 2010 AND DEFINED THEREON TO BE "AREAS DETERMINED TO BE OUTSIDE THE 0.2% ANNUAL CHANCE FLOODPLAIN."
- A DESCRIPTION OF EVEN DATE ACCOMPANIES THIS SURVEY.

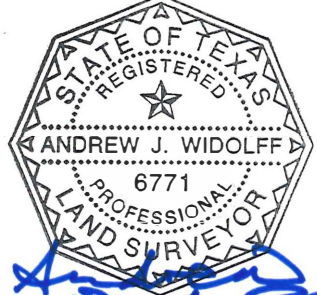

9.26.23
ANDREW J. WIDLOFF RPLS NO. 6771
FIRM NAME: WEAVER CONSULTANTS GROUP, LLC
6420 SOUTHWEST BLVD STE #206
FORT WORTH, TX 76103 (817) 735-9770
FIRM NO. 10095400

Weaver Consultants Group

11/13-5

SHEET 4 OF 4

No.	DATE	REVISION DESCRIPTION

REGISTRATION BOUNDARY
327,291 SQUARE FEET (7.513 ACRES) OUT OF THE DEMACI DE LAS REYES
SURVEY NO. 26 ABSTRACT NO. 618 & THE O.H. PETERS SURVEY NO. 138, ABSTRACT NO. 596
10244 FM 1346 ADKINS, BEXAR COUNTY, TEXAS

PREPARED FOR:
Waste Connections Inc.
Caring with the Future™

14 PROPERTY OWNER AFFIDAVIT

The property owner affidavit is included on the following page.

*This section
addresses
§330.59(d)(2).*

PROPERTY OWNER AFFIDAVIT

STATE OF TEXAS §
 §
COUNTY OF BEXAR §

On this day, Brett O'Connor, on behalf of Waste Connections Lone Star, Inc., appeared before me, the undersigned notary public, and after I administered an oath to him, upon his oath he said:

“My name is Brett O'Connor. I am more than 21 years of age and capable of making this affidavit.”

Waste Connections Lone Star, Inc. hereafter referred to as the property owner, acknowledges that:

- Lealco, Inc. is filing an application with the Texas Commission on Environmental Quality to operate a Type V municipal solid waste transfer station on real property owned by Waste Connections Lone Star, Inc. and located in Bexar County, Texas, being more particularly described in Parts I/II – Section 13 of the application (the Site).
- Waste Connections Lone Star, Inc. acknowledges that the State of Texas may hold the property owner of record, either jointly or severally responsible for the operation, maintenance, and closure and closure care of the facility.
- Waste Connections Lone Star, Inc. acknowledges that the owner or operator of the site and the State of Texas shall have access to the Site during the active life and closure period, and if required, after closure for the purpose of inspection and maintenance.

Brett O'Connor
Region Engineering Manager



Signature

1/17/24

Date

15 LEGAL AUTHORITY

The certificates provided on the following pages document the legal status of the applicant.

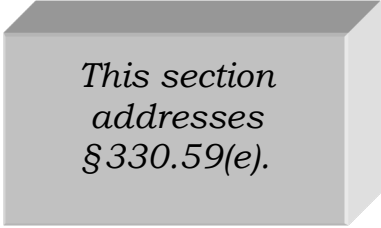

*This section
addresses
§330.59(e).*



Office of the Secretary of State

**CERTIFICATE OF FILING
OF**

**Waste Connections Lone Star, Inc.
131598000**

[formerly: Progressive Waste Solutions of TX, Inc.]

The undersigned, as Secretary of State of Texas, hereby certifies that a Certificate of Amendment for the above named entity has been received in this office and has been found to conform to the applicable provisions of law.

ACCORDINGLY, the undersigned, as Secretary of State, and by virtue of the authority vested in the secretary by law, hereby issues this certificate evidencing filing effective on the date shown below.

Dated: 06/18/2018

Effective: 06/18/2018



A handwritten signature in black ink, appearing to read "R. Pablos".

Rolando B. Pablos
Secretary of State

I/II-15-2

Come visit us on the internet at <http://www.sos.state.tx.us/>

Form 424
(Revised 05/11)

Submit in duplicate to:
Secretary of State
P.O. Box 13697
Austin, TX 78711-3697
512 463-5555
FAX: 512/463-5709
Filing Fee: See instructions



Certificate of Amendment

This space reserved for office use.
FILED
In the Office of the
Secretary of State of Texas
JUN 18 2018
Corporations Section

Entity Information

The name of the filing entity is:

Progressive Waste Solutions of TX, Inc.

State the name of the entity as currently shown in the records of the secretary of state. If the amendment changes the name of the entity, state the old name and not the new name.

The filing entity is a: (Select the appropriate entity type below.)

- | | |
|--|---|
| <input checked="" type="checkbox"/> For-profit Corporation | <input type="checkbox"/> Professional Corporation |
| <input type="checkbox"/> Nonprofit Corporation | <input type="checkbox"/> Professional Limited Liability Company |
| <input type="checkbox"/> Cooperative Association | <input type="checkbox"/> Professional Association |
| <input type="checkbox"/> Limited Liability Company | <input type="checkbox"/> Limited Partnership |

The file number issued to the filing entity by the secretary of state is: 131598000

The date of formation of the entity is: 06/17/1994

Amendments

1. Amended Name

(If the purpose of the certificate of amendment is to change the name of the entity, use the following statement)

The amendment changes the certificate of formation to change the article or provision that names the filing entity. The article or provision is amended to read as follows:

The name of the filing entity is: (state the new name of the entity below)

Waste Connections Lone Star, Inc.

The name of the entity must contain an organizational designation or accepted abbreviation of such term, as applicable.

2. Amended Registered Agent/Registered Office

The amendment changes the certificate of formation to change the article or provision stating the name of the registered agent and the registered office address of the filing entity. The article or provision is amended to read as follows:

Effectiveness of Filing (Select either A, B, or C.)

- A. This document becomes effective when the document is filed by the secretary of state.
- B. This document becomes effective at a later date, which is not more than ninety (90) days from the date of signing. The delayed effective date is: _____
- C. This document takes effect upon the occurrence of a future event or fact, other than the passage of time. The 90th day after the date of signing is: _____

The following event or fact will cause the document to take effect in the manner described below:

Execution

The undersigned signs this document subject to the penalties imposed by law for the submission of a materially false or fraudulent instrument and certifies under penalty of perjury that the undersigned is authorized under the provisions of law governing the entity to execute the filing instrument.

Date: June 1, 2018

By: _____

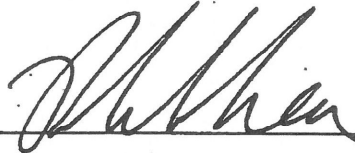

Signature of authorized person

Patrick J. Shea, Senior VP, Gen. Counsel & Secretary

Printed or typed name of authorized person (see instructions)

16 EVIDENCE OF COMPETENCY

16.1 Solid Waste Sites

The San Antonio TS is owned and operated by Waste Connections Lone Star, Inc. (WCLSI). WCLSI is a wholly-owned subsidiary of Waste Connections US Holdings, Inc. Over the past 15 years, Waste Connections US Holdings, Inc. and Lealco, Inc. have owned, operated, and/or controlled the Texas solid waste sites identified in Table 16-1.

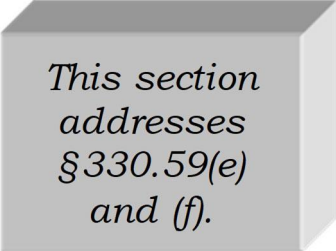

This section addresses §330.59(e) and (f).

WCLSI is generally noted that other wholly-owned subsidiaries of Waste Connections US Holdings, Inc have a financial interest in solid waste operations located in 40 states and the District of Columbia; and Waste Connections US Holdings, Inc. is affiliated with Waste Connections of Canada, Inc., whose subsidiaries have a financial interest in solid waste operations located in five Canadian provinces. The ultimate parent corporation for the foregoing companies is Waste Connections (WCI), a publicly-traded company listed on the Toronto Stock Exchange (TSX) and the New York Stock Exchange (NYSE), which is one of the largest solid waste services companies in North America. Additional information regarding WC's locations and operations throughout the United States and Canada is available at www.wasteconnections.com/locations.

16.2 San Antonio Transfer Station Key Personnel

The key personnel that will be involved in the management and operations of the proposed San Antonio TS are listed below:

Brett O'Connor, Region Engineering Manager

Mr. O'Connor serves as the Region Engineering Manager for over 25 landfills, hauling, and transfer operations in the Southern Region. Mr. O'Connor has management and oversight responsibilities for environmental compliance issues for WCLSI's solid waste disposal processing and transfer facilities in the Southern Region. Mr. O'Connor has over 14 years of experience designing, constructing, and operating municipal solid waste facilities.

Gary Bartels, Southern Region Engineer

Mr. Bartels serve as the Southern Region Engineer, and assists the Southern Region Engineering Manager with all aspects of management and environmental compliance for Texas landfills, hauling and transfer operations in the Southern Region area. Mr. Bartels has over 22 years of experience, constructing, and operating municipal solid waste facilities.

Dillon Hoppe, Southern Region Engineer

16.3 Equipment

The equipment listed in Part IV, Site Operating Plan is used to operate this site. Additional or different units of equipment may be provided as necessary to enhance operational efficiency. Other equivalent types of equipment may be substituted for this equipment on an as-needed basis.

**Table 16-1
Texas Solid Waste Management Facilities
(as of April 2024)**

Site Name	Type	Registration/ Permit Number	County	Dates of Operation
Archer City Transfer Station	V	40008	Archer	8/99 to 12/99
Bastrop Transfer Station	V	40291	Bastrop	5/2023 to present
Blanco County Transfer Station	V	40007	Blanco	5/97 to 12/03
Blanco County Transfer Station	V	2300	Blanco	12/03 to present
Blossom Prairie Landfill, Inc.	I	2358	Lamar	6/19 to present
Bowie Transfer Station	V	40101	Montague	7/99 to 12/03
Bowie Transfer Station	V	40171	Montague	10/01 to 3/03
Bowie Transfer Station	V	2295	Montague	9/02 to present
Buffalo Creek Landfill	IV	1571A	Wichita	7/99 to present
Brazoria County Transfer Station	V	2235	Brazoria	1992 to present
City of Canton Transfer Station	V	40266	Van Zandt	6/19 to present
City of Vernon Transfer Station	V	40059	Wilbarger	8/99 to present
Crockett Transfer Station (Closed)	V	40033	Houston	3/11 to 3/24/21 - Voluntary Revocation of Registration Issued by TCEQ
East Texas Regional Landfill	I	1249B	Rusk	8/99 to present
Fannon County Transfer Station	V	40290	Fannin	6/19 to present
Fort Worth C&D Landfill	IV	1983C	Tarrant	7/97 to present
Granbury Transfer Station	V	1592A	Hood	8/05 to 12/09
Hardin County Landfill	I	2214A	Hardin	10/02 to 9/17
Hardy Road Transfer Station	V	1578	Harris	1984 to present
Iowa Park Transfer Station	V	40135	Wichita	7/99 to 7/03
Jacksboro Landfill	I	2332	Jack	2/2024 to present
Lake Country/Mingus Transfer Station	V	40104	Palo Pinto	6/97 to present
Lake Country/Mingus Transfer Station	V	40201	Palo Pinto	1/04 to present
Lost Pines Transfer Station		40291	Bastrop	2017 to present
Minnis Drive Transfer Station	V	40159	Tarrant	9/00 to 11/05
Minnis Drive Transfer Station	V	2306	Tarrant	5/05 to present
Palestine Transfer Station	V	40040	Anderson	3/11 to 6/17
Palestine Transfer Station	V	2389	Anderson	6/17 to present
Pittsburg Transfer Station Facility	V	40174	Camp	6/19 to present

Table 16-1 (Continued)
Texas Solid Waste Management Facilities
(as of April 2024)

Site Name	Type	Registration/ Permit Number	County	Dates of Operation
Post Oak Landfill	I	2378	Guadalupe	12/21 to present
Pro Star Transfer Station	V	40277	Polk	2015 to present
Seabreeze Environmental Landfill	I	1539A	Brazoria	2009 to present
Somervell County Transfer Station	V	40181	Somervell	5/03 to 10/15
Travis County Landfill	IV	1841A	Travis	6/00 to present
Turkey Creek Landfill	I	1417D	Tarrant	5/09 to present
Weatherford Landfill	I	47A	Parker	7/03 to present
Weatherford Transfer Station	V	10301	Parker	1/22 to present
Wichita County C&D Landfill (Closed)	IV	1827B	Wichita	7/99 to closure
Williamson Transfer Station	V	2398	Williamson	2024 (anticipated)

17 APPOINTMENTS

The appointment prepared for this application meets the requirements of Title 30 TAC §330.59(g) and §305.44. The Notice of Appointment is provided on the following page.

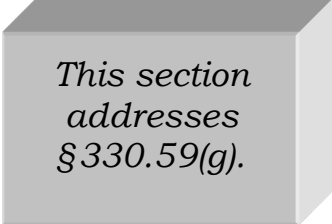

*This section
addresses
§330.59(g).*

**WRITTEN CONSENT OF
THE SOLE DIRECTOR OF
WASTE CONNECTIONS LONE STAR, INC.**

The undersigned, being the sole director of Waste Connections Lone Star, Inc., a Texas corporation (the "Company"), hereby consents to the following actions and adopts the following resolutions:

BE IT RESOLVED, that Brett O'Connor, Environmental Engineer of the Company, is hereby authorized to execute by and on behalf of the Company any and all documents required in connection with regulatory reports, filings, and other documentation relating to and necessary for the day-to-day operations of the Company with the Texas Commission on Environmental Quality.

IN WITNESS WHEREOF, the undersigned sole director of the Company has duly executed this Written Consent in The Woodlands, Texas on the date set forth below.

Dated: August 28, 2018



Ronald J. Mittelstaedt, Director

APPENDIX I/IIA

DEMONSTRATION OF COORDINATION

- Coordination with Texas Department of Transportation
- Coordination with Texas Historical Commission
- Coordination with Texas Parks and Wildlife Department
- Coordination with Alamo Area Council of Governments

COORDINATION WITH TEXAS DEPARTMENT OF TRANSPORTATION

CONTENTS

- February 22, 2024 TxDOT approval email.
- December 3, 2023 TxDOT Traffic Study submitted to TxDOT.

FEBRUARY 22, 2024 TXDOT APPROVAL EMAIL

From: [Jason Lambert](#)
To: [Marsh, Chuck](#)
Subject: Re: San Antonio - TCEQ application coordination
Date: Thursday, February 22, 2024 8:24:47 AM
Attachments: [image959390.png](#)
[image965812.png](#)
[image373593.png](#)

CAUTION: This email originated from outside your organization. Exercise caution when opening attachments or clicking links, especially from unknown senders.

Good morning Chuck,

I was able to dig into this review yesterday, and the increase in trips was a concern for us. We do not have an objection to development of the site, however, based on that large of a PHT increase and being on a high-speed facility TxDOT would require roadway widening to separate turn movements from thru traffic. I anticipate having our formal response letter with more details ready to go by end of week.

Thanks,

Jason J. Lambert, P.E.

Transportation Engineer Supervisor

Texas Department of Transportation | San Antonio District

O: (210) 615-6005 | C: (210) 287-8988 | Jason.Lambert@TxDOT.gov

From: Marsh, Chuck <cmarsh@wcgrp.com>
Sent: Thursday, February 22, 2024 7:32 AM
To: Jason Lambert <Jason.Lambert@txdot.gov>
Subject: RE: San Antonio - TCEQ application coordination

This email originated from outside of the organization. Do not click links or open attachments unless you recognize the sender and know the content is safe.

Good morning Jason,

Any news on our submittal for the San Antonio Transfer Station?

Thanks,

Charles Marsh, PE

Project Director

 Weaver Consultants Group

6420 Southwest Blvd. | Suite 206

Fort Worth, TX 76109

O: 817-735-9770 | F: 817-735-9775

cmarsh@wcgrp.com | www.wcgrp.com 

**DECEMBER 3, 2023 ENGINEERING STUDY
SUBMITTED TO TXDOT**



Project No. 0601-012-11-01
December 12, 2023

Mr. Jason Lambert
District Traffic Engineer
Texas Department of Transportation, San Antonio District
4615 NW Loop 410
San Antonio, Texas 78229

Re: Engineering Study
San Antonio Transfer Station
Bexar County, Texas

Dear Mr. Lambert:

The purpose of this letter, submitted on behalf of Texas Regional Landfill Company, LP (TRLIC), is to demonstrate coordination with the Texas Department of Transportation (TxDOT), consistent with Title 30 TAC §330.61(i)(4). This regulation requires that an applicant for a municipal solid waste (MSW) facility coordinate with TxDOT regarding any potential traffic or location restrictions. Weaver Consultants Group, LLC (WCG) submitted an engineering study for a Type V Registration Application on August 18, 2023. Due to changes in the proposed waste acceptance rate for the proposed San Antonio Transfer Station (TS), WCG is developing a Type V Permit application for this same facility. The proposed Type V Permit application does not change the property boundaries, the property owner, or the facility layout in any way and is intended to replace the August 18, 2023 Registration Application.

The proposed San Antonio TS located at 10244 FM 1346, Adkins, TX 78101, east of San Antonio, Bexar County, Texas will provide waste disposal services for the City of San Antonio, its residents, businesses, and the surrounding areas. The proposed TS will provide TRLIC the ability to collect, process, load, and transport solid waste more efficiently by allowing solid waste collection vehicles to transfer the solid waste into large transfer trailers before shipment to a permitted MSW landfill.

To assist you in your review, a project summary and site location maps have been provided as an overview of the TS. The attached engineering study demonstrates that the site access road, FM 1346, will provide adequate access to the site now and in the foreseeable future. It is expected that the traffic patterns will remain consistent with the current traffic patterns. The main change to the traffic patterns will be the addition of transfer trailers that will transport waste from the TS to regional permitted solid waste landfills.

To verify compliance with Title 30 TAC §330.61(i)(4), we are required by TCEQ to include a letter from TxDOT in the TS application regarding the adequacy of the site access roads and any traffic or location restrictions at or near the site.

Please call if you have any questions or need additional information.

Sincerely,

Weaver Consultants Group, LLC



Charles R. Marsh, P.E.
Project Director

Attachment: San Antonio Transfer Station Engineering Study

cc: Gary Bartels, Waste Connections, Inc.
Dillon Hoppe, Waste Connections, Inc.

**SAN ANTONIO TRANSFER STATION
BEXAR COUNTY, TEXAS
ENGINEERING STUDY**

Prepared for
Texas Regional Landfill Company, LP
November 2023

Prepared by
Weaver Consultants Group, LLC
TBPE Registration No. F-3727
6420 Southwest Boulevard, Suite 206
Fort Worth, Texas 76109
817-735-9770

WCG Project No. 0601-012-11-01

CONTENTS

1	INTRODUCTION	1
	1.1 Purpose	1
	1.2 Summary of Proposed Transfer Station	2
2	TRAFFIC INFORMATION	3
	2.1 Availability and Adequacy of Roads	3
	2.2 Volume of Vehicular Traffic	3
	2.3 Queuing	4
3	SUMMARY	7

APPENDIX A

Project Summary and Site Location Maps

1 INTRODUCTION

1.1 Purpose

Texas Regional Landfill Company, LP (TRLC) is in the process of preparing a Type V Municipal Solid Waste (MSW) Transfer Station (TS) Permit Application for a new MSW TS in Bexar County. The proposed San Antonio TS will provide waste transportation services for Bexar County, its residents, businesses and the surrounding areas. The proposed TS will provide TRLC with the ability to collect, load, and transport solid waste more efficiently by allowing the MSW collection vehicles to transfer MSW into large transfer trailers before shipment to permitted MSW landfills.

The purpose of the permit application to the Texas Commission on Environmental Quality (TCEQ) is to construct and operate the San Antonio TS facility which will process up to a maximum daily rate of 2,500 tons per day (tpd) of MSW. The facility's registration application will undergo a thorough technical review by the TCEQ before obtaining authorization to operate.

The purpose of this study is to show that the existing roadways will provide excellent access and the proposed TS will not adversely impact the existing and future traffic patterns of the facility access roads. This study is completed consistent with the requirements listed in 30 TAC §330.61(i), which requires the following information.

- Provide data on the availability and adequacy of roads that the owner or operator will use to access the site;
- Provide data on the volume of vehicular traffic on access roads within one mile of the proposed facility, both existing and expected, during the expected life of the proposed facility;
- Project the volume of traffic expected to be generated by the facility on the access roads within one mile of the proposed facility; and
- Submit documentation of coordination of all designs of proposed public roadway improvements such as turning lanes, storage lanes, etc., associated with site entrances with the agency exercising maintenance responsibility of the public roadway involved. In addition, the owner or operator shall submit documentation of coordination with the Texas Department of Transportation for traffic and location restrictions.

1.2 Summary of Proposed Transfer Station

The transfer station building will be a steel-framed structure with a metal roof and a total area of approximately 20,000 square feet. All transfer station vehicles (i.e., transfer trailers, collection vehicles, and self-haul vehicles) will enter the site by an existing driveway from FM 1346.

Incoming loads will be weighed and directed to the waste unloading area for transfer operations. The waste collection vehicle unloading area will consist of a well-lighted (overhead lighting) tipping floor where waste is unloaded onto the floor. Waste transfer operations will occur completely within the building. Waste deposited on the tipping floor within the building will be loaded into transfer trailers and hauled to an area landfill.

The facility will accept MSW and Class 2 and 3 industrial waste as permitted by the TCEQ. Properly trained personnel will operate the transfer station. A detailed site operating plan will be included in the transfer station registration application. The plan will detail the required equipment, personnel, and safety procedures required to operate the site in accordance with TCEQ regulations. A project summary and site location maps are provided in Appendix A.

2 TRAFFIC INFORMATION

2.1 Availability and Adequacy of Roads

As shown on Figure 2-1, the main access road within one mile of the site is FM 1346. Other roads within one mile of the site are shown on Figure 2-1. These roads may be periodically used by collection vehicles to serve residences and businesses located along or near these roadways; however, these roads are not main access roads that collection vehicles will use to access the site.

The San Antonio Transfer Station has two existing driveways connecting directly to FM 1346. The east driveway is proposed to be widened and used as the main facility entrance. The west driveway will be utilized by employees and visitors only. FM 1346 is suitable to handle the projected traffic load associated with the TS. FM 1346 is a two-lane, two-way asphalt road with a speed limit of 55 miles per hour.

Figure 2-2 shows the existing entrances to the facility. As shown on Figure 2-2, the east site entrance driveway is proposed to be a 30-foot-wide, 206-foot-long, concrete-paved driveway. The 206 feet of queuing space allows for at least 5 waste hauling vehicles to queue inside the facility gate, providing sufficient queuing area for waste vehicles, as noted in Section 2.4. The west driveway is 15 feet wide and provides access to the existing office building and parking areas.

2.2 Volume of Vehicular Traffic

The volume of vehicle traffic for FM 1346 is summarized on Table 2.1. As noted on Table 2.1, traffic counts for FM 1346 were taken from the TxDOT Traffic Count Database System (TCDS). The TxDOT traffic counts were adjusted to account for the additional traffic created by area growth from 2021 to 2023. Existing traffic volumes were projected to the year 2043 to evaluate the future performance of the site access road.

Traffic counts associated with the transfer station are estimated as shown on Table 2.1. The proposed maximum transfer capacity of the facility is 2,500 tons/day. Therefore, traffic projections were developed for traffic patterns that will occur at the proposed transfer station capacity of 2,500 tons/day.

The traffic volume impact assessment is summarized in Table 2.2. As shown, there is a minimal impact on FM 1346 throughout the projected life of the TS facility. The level of service (LOS) for FM 1346 was calculated using road characteristics, road capacities, and formulas obtained from the Highway Capacity Manual, 2016. As shown on Table 2.2, FM 1346 has an LOS of B. With the projected traffic counts to 2043, the LOS will remain the same. The TS only utilizes a small percentage of the capacity of FM 1346 (less than 4 percent in all cases) for the current and future projections.

2.3 Queuing

As shown on Figure 2-2, approximately 450 feet of queuing space within the facility gate provides for approximately ten waste hauling vehicles between the scale and FM 1346. An additional 174 feet (two lanes) of queueing space is available between the scale and the TS building. The available queuing area is sufficient to avoid disturbance on FM 1346.

**Table 2-1
2-Way Traffic Volumes**

Facility Capacity (Tons/Day)	Road	2-Way Traffic Volumes		Existing Traffic Volume 2023						Projected Traffic Volume ² 2043					
		Daily	Peak Hour ³	Daily			Peak Hour ³			Daily			Peak Hour ³		
				TS Trips ⁴	Non-TS Trips	Total ¹	TS Trips	Non-TS Trips	Total	TS Trips	Non-TS Trips	Total	TS Trips	Non-TS Trips	Total
2,500	FM 1346	3,028	303	1,540	2,258	3,798	154	226	380	1,540	2,794	4,334	154	279	433

Notes:

- ¹ Traffic count data was obtained from Texas Department of Transportation 2021 Traffic Count Database for FM 1346.
- ² The projected traffic volumes were obtained using projected growth rates for the surrounding area growth rate (non-Transfer Station vehicles). The growth rates were obtained from the Texas Water Development Board, 2021 Regional Water Plan. The annual population increase for 2021-2030 is 1.23%, for 2031-2040 is 1.01%, for 2041-2043 is 0.89%.
- ³ Peak hour volumes are assumed to be ten percent of total daily traffic.
- ⁴ One-way transfer station trips are estimated in the table below, then doubled to account for incoming and outgoing traffic.

24-Hour One-Way Transfer Station Vehicle Estimates⁵

Facility Capacity (Tons/Day)	Vehicle Type						Totals
	Rear Loader	Front Loader	Roll-Off	Low-Volume Vehicles	Facility Personal/Misc. Vehicles	Transfer Trailers	
2500	195	102	94	125	149	105	770

- ⁵ The number of vehicles per day was calculated based on truck capacity, density, and tonnage then doubled to account for all trucks entering and leaving the transfer station.

**Table 2-2
Traffic Impact Assessment¹**

Facility Capacity (Tons/Day)	Road	Roadway Capacity ⁴ (Vehicles/Day)	2023 Traffic Conditions ^{2,3} (No TS)			2023 Traffic Conditions ^{2,3} (With TS)				Projected 2043 Traffic Conditions ^{2,3}					
			Total Traffic (vpd)	% of Roadway Capacity Used	Level of Service	Transfer Station Traffic (vpd)	Total Traffic (vpd)	% of Roadway Capacity Used	Level of Service	% of Roadway Capacity Used by Transfer Station Vehicles	Transfer Station Traffic (vpd)	Total Traffic (vpd)	% of Roadway Capacity Used	Level of Service	% of Roadway Capacity Used by Transfer Station Vehicles
2,500	FM 1346	43,200	2,258	5.2%	B	1,440	3,798	8.8%	B	3.3%	1,440	4,334	10.0%	B	3.3%

Notes:

- ¹. Traffic volumes listed in this table include two-way traffic volumes.
- ². Traffic Count Data was obtained for Texas Department of Transportation 2021 Traffic Count Database for FM 1346.
- ³. The projected traffic volumes were obtained using projected growth rates for the surrounding area growth rate (non-Transfer Station vehicles). The growth rates were obtained from the Texas Water Development Board 2021 Regional Water Plan. The annual population increase for 2021-2030 is 1.23%, for 2031-2040 is 1.01%, for 2041-2043 is 0.89%.
- ⁴. Capacities were obtained or estimated using the Highway Capacity Manual, 2016.

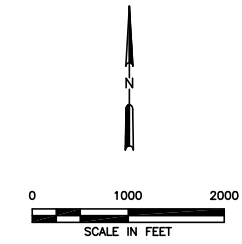

LEGEND
 - - - - - PERMIT BOUNDARY

NOTES:

1. AERIAL PHOTOGRAPHY PROVIDED BY GOOGLE EARTH FROM PHOTOGRAPH TAKEN 08-09-2022.

Tech. Complete App. - 112

<input type="checkbox"/> DRAFT <input checked="" type="checkbox"/> FOR PERMITTING PURPOSES ONLY <input type="checkbox"/> ISSUED FOR CONSTRUCTION	PREPARED FOR		PUBLIC ROADS WITHIN 1-MILE RADIUS
	TEXAS REGIONAL LANDFILL COMPANY, LP		
DATE: 10/2023 FILE: 0601-012-11 CAD: FIG 2.1-PUBLIC ROADS.DWG	DRAWN BY: RAA DESIGN BY: MB REVIEWED BY: CRM	SAN ANTONIO TRANSFER STATION BEXAR COUNTY, TEXAS	
Weaver Consultants Group TBPE REGISTRATION NO. F-3727		WWW.WCGRP.COM	
		FIGURE 2-1	

3 SUMMARY

In summary, the current 2023 area roadway system providing access to the San Antonio Transfer Station provides adequate access to the facility. Additionally, the current and projected 2043 traffic conditions would be minimally impacted by the proposed transfer station traffic. Therefore, the existing access roads within one mile of the site (FM 1346) will not be significantly impacted due to the proposed development of a transfer station.

APPENDIX A
PROJECT SUMMARY AND SITE LOCATION MAPS

Project Summary

San Antonio Transfer Station Texas Regional Landfill Company LP Bexar County, Texas

Introduction

Weaver Consultants Group, LLC is in the process of developing a Type V municipal solid waste (MSW) transfer station permit application for the proposed San Antonio Transfer Station (TS) on behalf of Texas Regional Landfill Company, LP (TRLCL).

The proposed San Antonio TS will provide waste disposal services for the City of San Antonio, its residents, businesses and the surrounding areas. The proposed TS will provide TRLCL with the ability to collect, load, and transport solid waste more efficiently by allowing the MSW collection vehicles to transfer MSW into large transfer trailers before shipment to other permitted MSW landfills.

The purpose of this application is to permit the development of the San Antonio TS which will process up to a permitted daily rate of 2,500 ton per day of MSW from the City of San Antonio, Bexar County, its residents, businesses and surrounding areas, and transfer this waste to a TCEQ-permitted MSW landfill. The facility's application will undergo a thorough technical review by the TCEQ before obtaining authorization to operate.

The proposed TS structure will consist of a 130-foot by 150-foot tipping floor (where incoming waste will be unloaded and transferred to waste transfer trailers). The facility is proposed to have a permitted rate of waste acceptance of 2,500 tpd of MSW. This summary provides an overview of the proposed TS. The following subsections detail information regarding the owner and operator of the site, general site information, and a summary of the proposed site design.

Owner/Operator Information

The San Antonio TS will be owned and operated by TRCL, a subsidiary of Waste Connections Inc., (WC). WC is one of the leading providers of solid waste services in North America. WC is an integrated solid waste services company that acquires, operates, and provides non-hazardous waste collection, transfer, recycling, and disposal services to residential, municipal, and commercial customers across the continental United States and southern Canada.

Site Information

The following drawings are attached to this summary.

- Site Location Map (Figure 1). This figure shows the site location on a standard Texas Department of Transportation Bexar County highway map.
- General Topographic Map (Figure 2). This figure shows the site location on a United States Geological Survey (USGS) map.
- Aerial Photograph (Figure 3). This figure shows the existing conditions of the site on an aerial photograph.
- Proposed Site Plan (Figure 4). This figure shows the proposed site plan for the TS.

The San Antonio TS will be located within the city limits on the east side of San Antonio in Bexar County, Texas. The site will be accessed from FM 1346, which is approximately 3.7 miles south of the intersection of Interstate 10 and FM 1604 and then 1.5 miles west of intersection of FM 1604 and FM 1346. The service area will include the City of San Antonio residents, businesses and surrounding rural areas.

Design Summary

The following information presents a summary of the design and operations for the San Antonio TS.

- The TS will be open on two sides and will consist of a steel-framed structure with a metal roof and partial siding on two sides. The proposed transfer capacity of the facility is 2,500 tpd of MSW. Incoming loads will be directed to the tipping floor for transfer operations. The TS area will consist of a well-lit tipping floor (via natural lighting and overhead lighting) where transfer operations from collection vehicles to transfer trailers will occur. MSW transfer operations will occur completely underneath the structure. MSW unloaded on the tipping floor within the TS will typically be pushed by front-end loaders to a grapple loader (or similar materials handling equipment), which will load the MSW into a transfer trailer. The grapple loader may also be used to compact the waste or more evenly distribute the waste within the transfer trailer. The transfer trailer will haul the MSW to a properly permitted Type I MSW landfill.
- Upon issuance of the required TCEQ authorization, the TS will accept MSW, construction and demolition wastes, special wastes, wood waste, green waste, recyclables and non-hazardous industrial waste as allowed by the TCEQ regulations.
- Once approved by the TCEQ, the facility will be operated in accordance with the TCEQ-approved site operating plan. This plan includes procedures that govern day-to-day operations of the facility as well as routine inspections and housekeeping to ensure compliance with the TCEQ regulations. As part of the

operations, litter, dust, and odor control measures and procedures will be implemented.

- Access to the TS will be provided via the existing driveways located on the south side of FM 1346 Road. Employees and visitors will use the west driveway. Vehicles bound for the tipping floor will use the expanded east driveway. All vehicles bound for the TS will be directed to access the site using the FM 1346 Road route. From FM 1604 Road, vehicles will travel west on FM 1346 Road for approximately 1.6 miles to the site entrance. The existing roads are suitable to handle the projected traffic load associated with the TS.
- Properly trained personnel will operate the TS, and TRLC will staff the facility in the future based on the personnel needs to effectively serve the community. A detailed site operating plan will be included in the transfer station application. The plan will provide details on the required equipment, personnel, and safety procedures necessary to operate the facility in accordance with TCEQ regulations. The San Antonio TS will be inspected by the TCEQ on a regular basis to ensure the site is in compliance with state regulations.

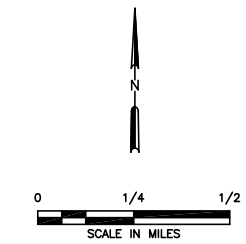
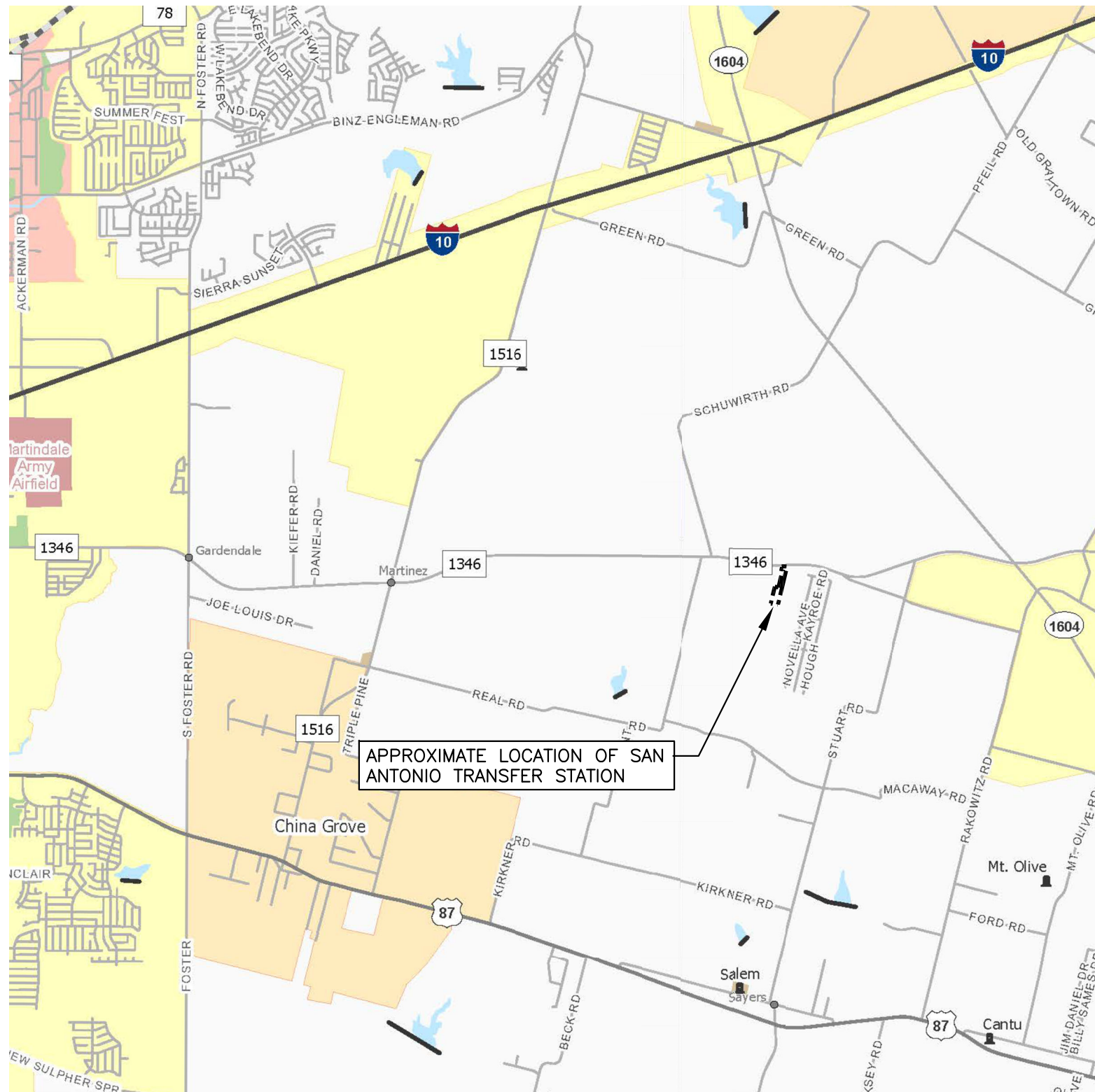

- LEGEND**
- PERMIT BOUNDARY
 - Unincorporated Community
 - ⊛ County Seat
 - ⊕ Border Crossing
 - ⊠ Cemetery
 - Cemetery (Inside City)
 - ⊕ Deep Draft Port
 - ⊕ Shallow Draft Port
 - Railroad
 - Dam
 - River or Stream
 - TXDOT District
 - Lakes
 - Education
 - Military
 - Airport Runway
 - Airport
 - Prison
 - Parks and Other Public Land

NOTES:

- REPRODUCED FROM THE COUNTY MAPBOOK 2018 (TEXAS DEPARTMENT OF TRANSPORTATION, TRANSPORTATION PLANNING, AND PROGRAMMING DIVISION).

Tech. Complete App. - 119

<input type="checkbox"/> DRAFT <input checked="" type="checkbox"/> FOR INFORMATION PURPOSES ONLY <input type="checkbox"/> ISSUED FOR CONSTRUCTION		PREPARED FOR TEXAS REGIONAL LANDFILL COMPANY, LP		TYPE V PERMIT APPLICATION SITE LOCATION MAP SAN ANTONIO TRANSFER STATION BEXAR COUNTY, TEXAS	
DATE: 10/2023 FILE: 0601-012-11 CAD: FIG 1-SITE LOCATION MAP.DWG		DRAWN BY: RAA DESIGN BY: MB REVIEWED BY: CRM			
		REVISIONS			
		NO.	DATE	DESCRIPTION	
Weaver Consultants Group TBPE REGISTRATION NO. F-3727				WWW.WCGRP.COM	FIGURE 1

O:\0601\12\TYPE V PERMIT APP\PROJECT SUMMARY\FIG 1-SITE LOCATION MAP.dwg, catweaver, 1:2

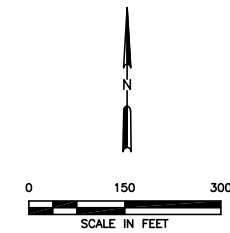

LEGEND
 - - - - - PERMIT BOUNDARY

NOTE:
 1. AERIAL PHOTOGRAPH PROVIDED BY GOOGLE EARTH DATED AUGUST 09, 2022.

Tech. Complete App. - 121

<input type="checkbox"/> DRAFT <input checked="" type="checkbox"/> FOR INFORMATION PURPOSES ONLY <input type="checkbox"/> ISSUED FOR CONSTRUCTION	PREPARED FOR TEXAS REGIONAL LANDFILL COMPANY, LP		TYPE V PERMIT APPLICATION AERIAL PHOTOGRAPH SAN ANTONIO TRANSFER STATION BEXAR COUNTY, TEXAS	
	DATE: 10/2023 FILE: 0601-012-11 CAD: FIG 3-AERIAL PHOTOGRAPH.DWG	DRAWN BY: RAA DESIGN BY: MB REVIEWED BY: CRM		
Weaver Consultants Group TBPE REGISTRATION NO. F-3727		NO.	DATE	DESCRIPTION
WWW.WCGRP.COM		FIGURE 3		

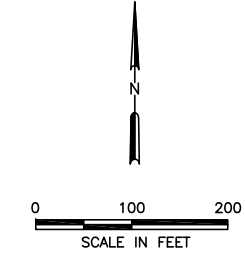
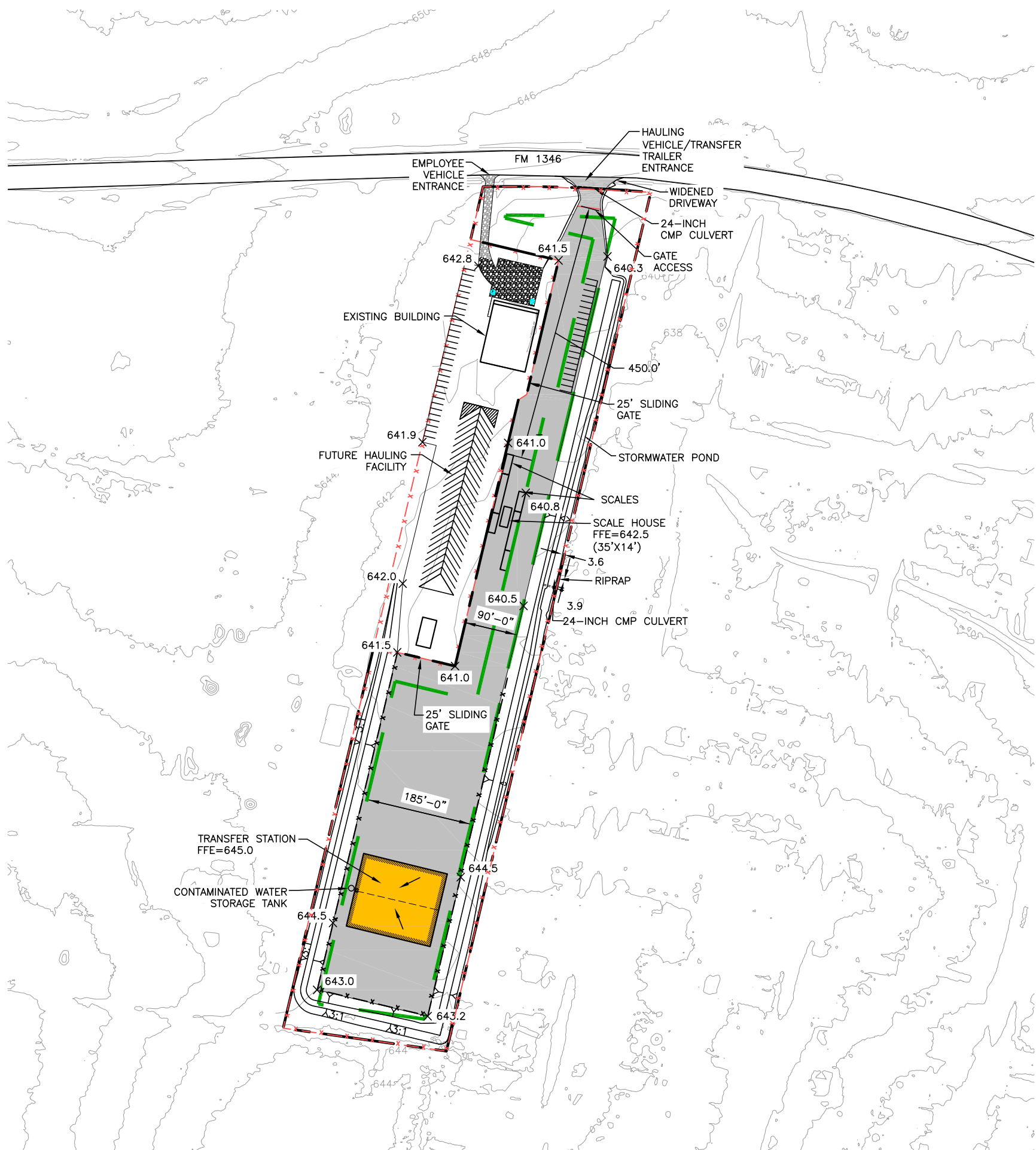

LEGEND

	PERMIT BOUNDARY
	EXISTING CONTOUR
	PROPOSED BUILDING
	EXISTING GRAVEL PAVEMENT
	PROPOSED GRAVEL PAVEMENT
	50-FOOT BUFFER ZONE
	ACCESS CONTROL FENCE (SEE NOTE 3)
	PROPOSED OPERATIONS AREA FENCE (SEE NOTE 2)
	PROPOSED CONCRETE OR ASPHALT PAVEMENT
	PROPOSED SPOT ELEVATION

NOTES:
 1. THE EXISTING CONTOURS PROVIDED BY TEXAS RESOURCE INFORMATION SYSTEM (TNRIS) BEXAR AND TRAVIS COUNTIES LIDAR, 2022.

Tech. Complete App. - 122

<input type="checkbox"/> 90% REVIEW <input checked="" type="checkbox"/> FOR INFORMATION PURPOSES ONLY <input type="checkbox"/> ISSUED FOR CONSTRUCTION	PREPARED FOR TEXAS REGIONAL LANDFILL COMPANY, LP		TYPE V PERMIT APPLICATION PROPOSED SITE PLAN SAN ANTONIO TRANSFER STATION BEXAR COUNTY, TEXAS			
	DATE: 10/2023 FILE: 0601-012-11 CAD: FIG 4-PROPOSED SITE PLAN.DWG	DRAWN BY: RAA DESIGN BY: MB REVIEWED BY: CRM			REVISIONS	
Weaver Consultants Group TBPE REGISTRATION NO. F-3727		NO.	DATE	DESCRIPTION	WWW.WCGRP.COM	FIGURE 4

O:\0601\12\TYPE V PERMIT APP\PROJECT SUMMARY\FIG 4-PROPOSED SITE PLAN.dwg - caweaver - 1:2

COORDINATION WITH TEXAS HISTORICAL COMMISSION

CONTENTS

- THC Conclusion that No Historic Properties Are Affected by the Transfer Station.
- August 18, 2023 THC Conformance Review Request

**THC CONCLUSION THAT NO HISTORIC PROPERTIES
ARE AFFECTED BY THE TRAFER STATION**

This Correspondence sent to cmarsh@wcgrp.com on 09-14-2023



Re: THC Courtesy Project Review

THC Tracking #202312621

Date: 09/14/2023

San Antonio Transfer Station

10244 FM 1346

San Antonio, TX

Description: Project includes construction of a solid waste transfer station and infrastructure. The goal of this review is to demonstrate compliance with 30TAC Â§330.61(o)

Dear Charles Marsh:

Thank you for your submittal regarding the above-referenced project. This response represents the comments of the Executive Director of the Texas Historical Commission (THC), as a courtesy review only and does not suffice for review under Section 106 of the National Historic Preservation Act or the Antiquities Code of Texas.

The review staff, led by Caitlin Brashear and Emily Dylla, has completed its review and has made the following determinations based on the information submitted for review:

Above-Ground Resources

- No further review of potential effects to above-ground historic resources is required under the Antiquities Code of Texas. However, should this project ultimately include any federal involvement, additional consultation with THC/SHPO under Section 106 of the National Historic Preservation Act will be required.

Archeology Comments

- No historic properties affected. However, if cultural materials are encountered during construction or disturbance activities, work should cease in the immediate area; work can continue where no cultural materials are present. Please contact the THC's Archeology Division at 512-463-6096 to consult on further actions that may be necessary to protect the cultural remains.

We look forward to further consultation with your office and hope to maintain a partnership that will foster effective historic preservation. Thank you for your cooperation in this review process, and for your efforts to preserve the irreplaceable heritage of Texas. If the project changes, or if new historic properties are found, please contact the review staff. If you have any questions concerning our review or if we can be of further assistance, please email the following reviewers: caitlin.brashear@thc.texas.gov, emily.dylla@thc.texas.gov.

This response has been sent through the electronic THC review and compliance system (eTRAC). Submitting your project via eTRAC eliminates mailing delays and allows you to check the status of the review, receive an electronic response, and generate reports on your submissions. For more information, visit <http://thc.texas.gov/etrac-system>.

Sincerely,

Caitlin Brashear

for Mark Wolfe, State Historic Preservation Officer
Executive Director, Texas Historical Commission

Please do not respond to this email.

AUGUST 18, 2023 THC CONFORMANCE REVIEW REQUEST

Ms. Donna McCarver
Texas Historical Commission
Archeology Division
P.O. Box 12276
Austin, Texas 78711-2276

Re: Historical and Cultural Resources Evaluation
San Antonio Transfer Station
Bexar County, Texas

Dear Ms. McCarver:

The purpose of this letter and Drawing, submitted on behalf of Texas Regional Landfill Company, LP (TRLIC), is to demonstrate coordination with the Texas Historical Commission (THC), consistent with Title 30 Texas Administrative Code (TAC) §330.61(o). This Texas Commission on Environmental Quality (TCEQ) regulation requires that an applicant for a municipal solid waste (MSW) facility coordinate with the THC regarding the potential impact of the project to the cultural resources of the State of Texas and compliance with the Texas Antiquities Code (Code). Weaver Consultants Group, LLC submitted a Historical and Cultural Resources Evaluation request on August 18, 2023, that was received on September 14, 2023 for a Type V registration application for the proposed San Antonio Transfer Station (TS) located at 10244 FM 1346, Adkins, Tx 78101, east of San Antonio, Bexar County, Texas. Due to changes in the proposed waste acceptance rate for the proposed San Antonio TS, WCG is developing a Type V Permit application for this same facility. The proposed Type V Permit application does not change the property boundaries, the property owner, or the facility layout in any way and is intended to replace the August 18, 2023 Registration Application.

A review of the THC Atlas website, which contains over 100,000 sites recorded at the Texas Archeological Research Laboratory in Austin, was performed. Based on information included on the THC website, the majority of recorded historic sites in Bexar County, Texas appears to be located west of the site within the City of San Antonio. The THC Atlas search results indicated no archeological site is located within one mile of the proposed transfer station tract. The San Antonio Transfer Station is located approximately 3 miles away from the closest historical site as shown on Figure 1.

To verify compliance with Title 30 TAC §330.61(o), we will need to include a letter from the THC within the TCEQ application. A determination of the potential impact of the project to the historical and cultural resources of the state of Texas, in compliance with the Code, is respectfully requested.

Ms. Donna McCarver

November 3, 2023

Your assistance with this matter is sincerely appreciated. Please call if you have any questions or need additional information.

Sincerely,

Weaver Consultants Group, LLC



Charles R. Marsh, P.E.
Project Director

Attachment 1: Figure 1 – THC ATLAS Location Map

Attachment 2: Project Summary and Site Location Maps

cc: Gary Bartels, Waste Connections, Inc.
Dillon Hoppe, Waste Connections, Inc.

ATTACHMENT 1

FIGURE 1 – THC ATLAS LOCATION MAP

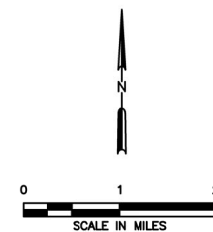

LEGEND

- Museum
- Historical Marker
- ★ National Register Properties
- Cemeteries

NOTES:

1. ATLAS AERIAL PROVIDED BY TEXAS HISTORICAL COMMISSION DATED AUGUST 14, 20S3.



Tech. Complete App. - 131

<input type="checkbox"/> DRAFT <input checked="" type="checkbox"/> FOR PERMITTING PURPOSES ONLY <input type="checkbox"/> ISSUED FOR CONSTRUCTION	PREPARED FOR TEXAS REGIONAL LANDFILL COMPANY, LP	TYPE V PERMIT APPLICATION THC ATLAS LOCATION MAP		
DATE: 06/2023 FILE: 0601-012-11 CAD: FIG 1-THC ATLAS LOCATION.DWG	DRAWN BY: RAA DESIGN BY: MB REVIEWED BY: CRM	REVISIONS		
		NO.	DATE	DESCRIPTION
Weaver Consultants Group TBPE REGISTRATION NO. F-3727		SAN ANTONIO TRANSFER STATION BEXAR COUNTY, TEXAS		
		WWW.WCGRP.COM		
		FIGURE 1		

O:\0601\12\TYPE V PERMIT APP\THC ATLAS\1-THC ATLAS LOCATION.DWG - caweaver - 1:2

ATTACHMENT 2

PROJECT SUMMARY AND SITE LOCATION MAPS

Project Summary

San Antonio Transfer Station Texas Regional Landfill Company LP Bexar County, Texas

Introduction

Weaver Consultants Group, LLC is in the process of developing a Type V municipal solid waste (MSW) transfer station permit application for the proposed San Antonio Transfer Station (TS) on behalf of Texas Regional Landfill Company, LP (TRLCL).

The proposed San Antonio TS will provide waste disposal services for the City of San Antonio, its residents, businesses and the surrounding areas. The proposed TS will provide TRLCL with the ability to collect, load, and transport solid waste more efficiently by allowing the MSW collection vehicles to transfer MSW into large transfer trailers before shipment to other permitted MSW landfills.

The purpose of this application is to permit the development of the San Antonio TS which will process up to a permitted daily rate of 2,500 ton per day of MSW from the City of San Antonio, Bexar County, its residents, businesses and surrounding areas, and transfer this waste to a TCEQ-permitted MSW landfill. The facility's application will undergo a thorough technical review by the TCEQ before obtaining authorization to operate.

The proposed TS structure will consist of a 130-foot by 150-foot tipping floor (where incoming waste will be unloaded and transferred to waste transfer trailers). The facility is proposed to have a permitted rate of waste acceptance of 2,500 tpd of MSW. This summary provides an overview of the proposed TS. The following subsections detail information regarding the owner and operator of the site, general site information, and a summary of the proposed site design.

Owner/Operator Information

The San Antonio TS will be owned and operated by TRCL, a subsidiary of Waste Connections Inc., (WC). WC is one of the leading providers of solid waste services in North America. WC is an integrated solid waste services company that acquires, operates, and provides non-hazardous waste collection, transfer, recycling, and disposal services to residential, municipal, and commercial customers across the continental United States and southern Canada.

Site Information

The following drawings are attached to this summary.

- Site Location Map (Figure 1). This figure shows the site location on a standard Texas Department of Transportation Bexar County highway map.
- General Topographic Map (Figure 2). This figure shows the site location on a United States Geological Survey (USGS) map.
- Aerial Photograph (Figure 3). This figure shows the existing conditions of the site on an aerial photograph.
- Proposed Site Plan (Figure 4). This figure shows the proposed site plan for the TS.

The San Antonio TS will be located within the city limits on the east side of San Antonio in Bexar County, Texas. The site will be accessed from FM 1346, which is approximately 3.7 miles south of the intersection of Interstate 10 and FM 1604 and then 1.5 miles west of intersection of FM 1604 and FM 1346. The service area will include the City of San Antonio residents, businesses and surrounding rural areas.

Design Summary

The following information presents a summary of the design and operations for the San Antonio TS.

- The TS will be open on two sides and will consist of a steel-framed structure with a metal roof and partial siding on two sides. The proposed transfer capacity of the facility is 2,500 tpd of MSW. Incoming loads will be directed to the tipping floor for transfer operations. The TS area will consist of a well-lit tipping floor (via natural lighting and overhead lighting) where transfer operations from collection vehicles to transfer trailers will occur. MSW transfer operations will occur completely underneath the structure. MSW unloaded on the tipping floor within the TS will typically be pushed by front-end loaders to a grapple loader (or similar materials handling equipment), which will load the MSW into a transfer trailer. The grapple loader may also be used to compact the waste or more evenly distribute the waste within the transfer trailer. The transfer trailer will haul the MSW to a properly permitted Type I MSW landfill.
- Upon issuance of the required TCEQ authorization, the TS will accept MSW, construction and demolition wastes, special wastes, wood waste, green waste, recyclables and non-hazardous industrial waste as allowed by the TCEQ regulations.
- Once approved by the TCEQ, the facility will be operated in accordance with the TCEQ-approved site operating plan. This plan includes procedures that govern day-to-day operations of the facility as well as routine inspections and housekeeping to ensure compliance with the TCEQ regulations. As part of the

operations, litter, dust, and odor control measures and procedures will be implemented.

- Access to the TS will be provided via the existing driveways located on the south side of FM 1346 Road. Employees and visitors will use the west driveway. Vehicles bound for the tipping floor will use the expanded east driveway. All vehicles bound for the TS will be directed to access the site using the FM 1346 Road route. From FM 1604 Road, vehicles will travel west on FM 1346 Road for approximately 1.6 miles to the site entrance. The existing roads are suitable to handle the projected traffic load associated with the TS.
- Properly trained personnel will operate the TS, and TRLC will staff the facility in the future based on the personnel needs to effectively serve the community. A detailed site operating plan will be included in the transfer station application. The plan will provide details on the required equipment, personnel, and safety procedures necessary to operate the facility in accordance with TCEQ regulations. The San Antonio TS will be inspected by the TCEQ on a regular basis to ensure the site is in compliance with state regulations.

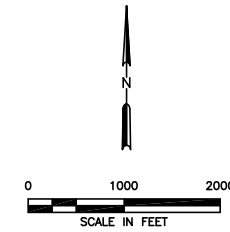
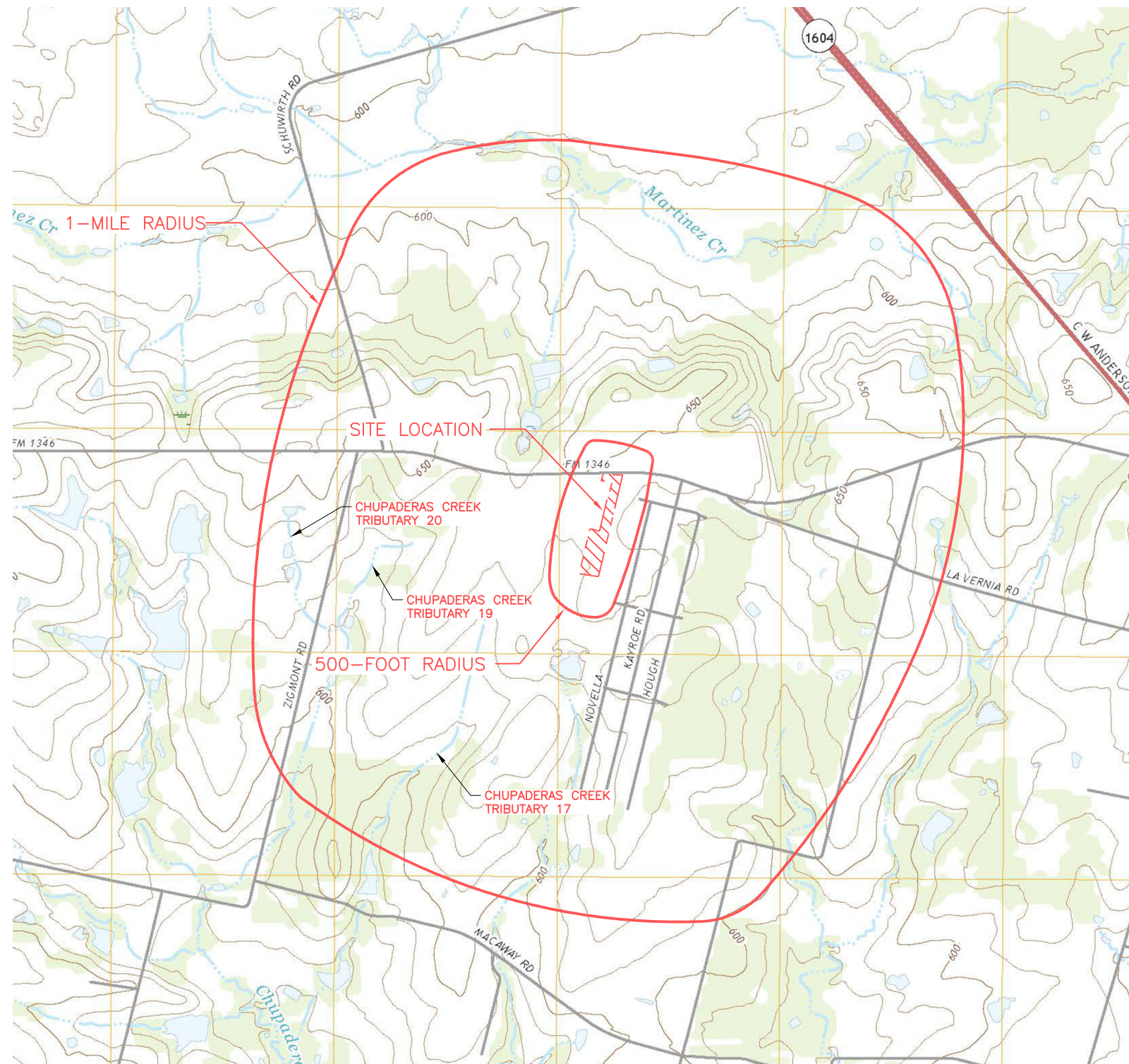

LEGEND

ROAD CLASSIFICATION

Expressway		Local Connector	
Secondary Hwy		Local Road	
Ramp		4WD	
	Interstate Route		US Route
	State Route		

NOTE:
 1. ADAPTED FROM THE USGS 7.5 MINUTE QUADRANGLE TOPOGRAPHIC MAPS (MARTINEZ, TX 2022)

Tech. Complete App. - 137

<input type="checkbox"/> DRAFT <input checked="" type="checkbox"/> FOR INFORMATION PURPOSES ONLY <input type="checkbox"/> ISSUED FOR CONSTRUCTION	PREPARED FOR TEXAS REGIONAL LANDFILL COMPANY, LP		TYPE V REGISTRATION APPLICATION GENERAL TOPOGRAPHIC MAP SAN ANTONIO TRANSFER STATION BEXAR COUNTY, TEXAS			
	DATE: 10/2023 FILE: 0601-012-11 CAD: FIG 2-GENERAL TOPO MAP.DWG	DRAWN BY: RAA DESIGN BY: MB REVIEWED BY: CRM			REVISIONS	
Weaver Consultants Group TBPE REGISTRATION NO. F-3727		NO.	DATE	DESCRIPTION	WWW.WCGRP.COM	FIGURE 2

O:\0601\12\TYPE V PERMIT APP\PROJECT SUMMARY\FIG 2-TOPO MAP.DWG - caweaover - 1:2

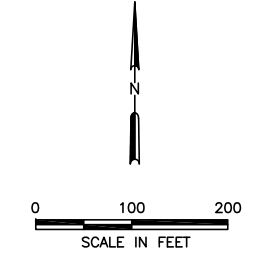
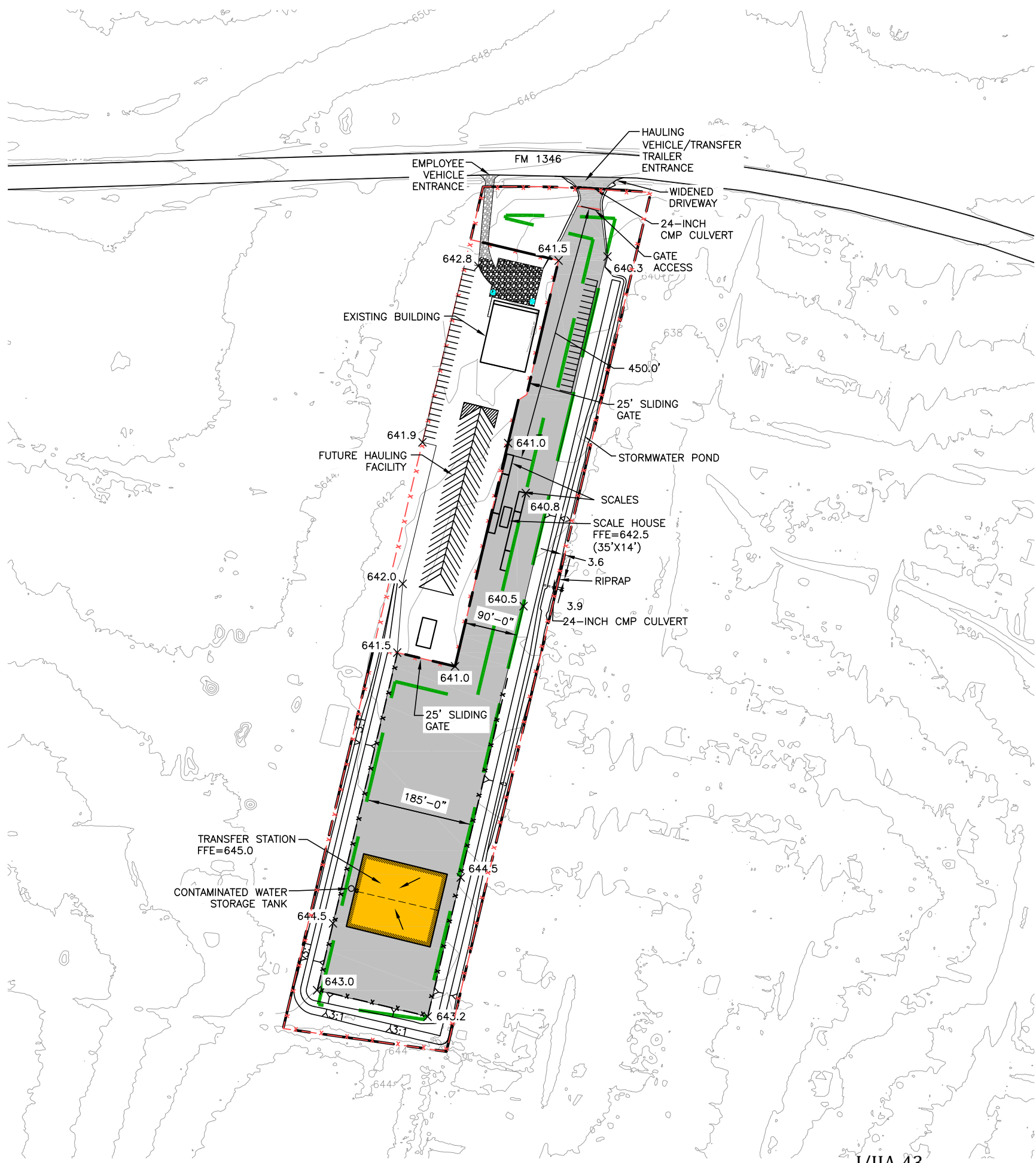

LEGEND

	PERMIT BOUNDARY
	EXISTING CONTOUR
	PROPOSED BUILDING
	EXISTING GRAVEL PAVEMENT
	PROPOSED GRAVEL PAVEMENT
	50-FOOT BUFFER ZONE
	ACCESS CONTROL FENCE (SEE NOTE 3)
	PROPOSED OPERATIONS AREA FENCE (SEE NOTE 2)
	PROPOSED CONCRETE OR ASPHALT PAVEMENT
	PROPOSED SPOT ELEVATION

NOTES:
 1. THE EXISTING CONTOURS PROVIDED BY TEXAS RESOURCE INFORMATION SYSTEM (TNRIS) BEXAR AND TRAVIS COUNTIES LIDAR, 2022.

Tech. Complete App. - 139

<input type="checkbox"/> 90% REVIEW <input checked="" type="checkbox"/> FOR INFORMATION PURPOSES ONLY <input type="checkbox"/> ISSUED FOR CONSTRUCTION	PREPARED FOR		TEXAS REGIONAL LANDFILL COMPANY, LP TYPE V PERMIT APPLICATION PROPOSED SITE PLAN SAN ANTONIO TRANSFER STATION BEXAR COUNTY, TEXAS									
	DATE: 10/2023 FILE: 0601-012-11 CAD: FIG 4-PROPOSED SITE PLAN.DWG			DRAWN BY: RAA DESIGN BY: MB REVIEWED BY: CRM								
WEAVER CONSULTANTS GROUP TBPE REGISTRATION NO. F-3727		REVISIONS <table border="1"> <thead> <tr> <th>NO.</th> <th>DATE</th> <th>DESCRIPTION</th> </tr> </thead> <tbody> <tr> <td> </td> <td> </td> <td> </td> </tr> <tr> <td> </td> <td> </td> <td> </td> </tr> </tbody> </table>	NO.	DATE	DESCRIPTION							WWW.WCGRP.COM FIGURE 4
NO.	DATE	DESCRIPTION										

O:\0601\12\TYPE V PERMIT APP\PROJECT SUMMARY\FIG 4-PROPOSED SITE PLAN.dwg - caweaver - 1:2

COORDINATION WITH TEXAS PARKS AND WILDLIFE DEPARTMENT

CONTENTS

- TPWD Conclusion that site development would not have an adverse impact to rare, threatened, or endangered species or other fish and wildlife resources.
- August 18, 2023 TPWD Conformance Review Request.

TPWD CONCLUSION

Marsh, Chuck

From: Russell Hooten <Russell.Hooten@tpwd.texas.gov>
Sent: Wednesday, September 27, 2023 2:02 PM
To: Marsh, Chuck
Cc: Russell Hooten
Subject: TPWD Review (#51316) San Antonio Transfer Station, Bexar Co.

CAUTION: This email originated from outside your organization. Exercise caution when opening attachments or clicking links, especially from unknown senders.

Good afternoon Mr. Marsh,

Thank you for submitting the proposed San Antonio Transfer Station threatened and endangered species assessment to Texas Parks and Wildlife Department (TPWD) for review. Texas Regional Landfill Company proposes to construct a Type V municipal solid waste transfer station along the south side of Farm-to-Market Road (FM) 1346, east of San Antonio, Bexar County, Texas.

Based on a review of the documentation and project description provided, TPWD – Ecological and Environmental Planning Program does not anticipate significant adverse impacts to rare, threatened, or endangered species, or other fish and wildlife resources. However, please note it is the responsibility of the project proponent to comply with all federal, state, and local laws that protect fish and wildlife. Provided the current project plans do not change, TPWD considers coordination to be complete.

Sincerely
Russell

Russell Hooten
Environmental Review Biologist
Ecological and Environmental Planning Program
TPWD-Wildlife Division
1409 Waldron Road
Corpus Christi, TX 78418
russell.hooten@tpwd.texas.gov
361-431-6003 Office

AUGUST 18, 2023 TPWD CONFORMANCE REVIEW REQUEST

Mr. John Silovsky
Director of Wildlife
Texas Parks and Wildlife Department
4200 Smith School Road
Austin, Texas 78744

Re: Request for Threatened or Endangered Species Assessment
San Antonio Transfer Station
Bexar County, Texas

Dear Mr. Silovsky:

The purpose of this letter, submitted on behalf of Texas Regional Landfill Company, LP (TRLIC), is to demonstrate coordination with the Texas Parks and Wildlife Department (TPWD), at the request of the Texas Commission on Environmental Quality (TCEQ). The TCEQ requires that an applicant for a municipal solid waste (MSW) facility consider the impact on threatened or endangered species and not result in the destruction or adverse modification of the critical habitat of threatened or endangered species, or cause or contribute to the taking of any threatened or endangered species.

Weaver Consultants Group, LLC is preparing a Type V MSW Registration Application, under contract with TRLIC to obtain the necessary authorization for the proposed San Antonio Transfer Station (TS). The site will be located at 10244 FM 1346, Adkins, TX 78101, east of San Antonio, Bexar County, Texas.

WCG completed a site specific biological report including a Threatened and Endangered Species Assessment (T&E) on July 12, 2023. The biological study reported that the United States Fish and Wildlife Service lists 12 species as federally threatened/endangered in Bexar County, and the Texas Parks and Wildlife Department lists 24 species as threatened or endangered in the same area. The following are the federally and state listed species:

The golden-cheeked warbler (*Setophaga chrysoparia*), The whooping crane (*Grus americana*), The piping plover (*Charadrius melodus*), The red knot (*Calidris canutus rufa*), The white-faced ibis (*Plegadis chihi*), The wood stork (*Mycteria americana*), The San Marcos salamander (*Eurycea nana*), The Cascade Caverns salamander (*Eurycea latitans*), The Texas salamander (*Eurycea neotenes*), The Cokendolpher Cave Harvestman (*Texella cokendolpheri*), The Government Canyon Bat Cave Meshweaver (*Cicurina*), The Government Canyon Bat Cave Spider (*Tayshaneta microps*), The Madla Cave Meshweaver (*Cicurina madla*), The Robber Baron Cave Meshweaver (*Cicurina baronia*), The fountain darter (*Etheostoma fonticola*), The

toothless blindcat (*Trogloglanis pattersoni*), The widemouth blindcat (*Satan eurystomus*), The black bear (*Ursus americana*), The white-nosed coati (*Nasua narica*), The false spike (*Fusconaia mitchelli*), The Cagle's map turtle (*Graptemys caglei*), The Texas horned lizard (*Phrynosoma cornutum*) and The Texas tortoise (*Gopherus berlandieri*). Tricolored Bat (*Perimyotis subflavus*), Two beetle species (*Rhadine exilis* and *Rhadine infernalis*), Helotes Mold Beetle (*Batrisodes venyivi*), and Monarch Butterfly (*Danaus plexippus*).

The T&E study concluded that no critical habitat for any threatened or endangered species occurs within the Project Site. A request for rare species occurrences information was submitted to the Texas Parks and Wildlife Department Natural Diversity Database. Based on the research and field observations, there are no threatened/endangered species or their critical habitat within the Project Site. Based on the T&E Study, the construction of the San Antonio TS will not result in the destruction or adverse modification to any critical habitat of any endangered or threatened species, or cause or contribute to the taking of any endangered or threatened species. It is WCG's opinion that the new TS facility would have no effect on federally or state-listed T&E species.

To assist you in your determination regarding threatened or endangered species or their critical habitat within or near the referenced project, please find attached a project summary and site location maps.

To verify compliance with TCEQ, this letter is to request concurrence from the TPWD that the proposed expansion will have no effect on any federal or state-listed T&E species to include with the permit amendment application.

Please call if you have any questions or need additional information.

Sincerely,

Weaver Consultants Group, LLC



Charles R. Marsh, P.E.
Project Director

Attachment: Attachment 1 – Project Summary and Site Location Maps
Attachment 2 – T&E Study by Weaver Consultants Group

cc: Gary Bartels, Texas Regional Landfill Company, LP
Dillon Hoppe, Waste Connections, Inc.

ATTACHMENT 1
PROJECT SUMMARY AND SITE LOCATION MAPS

Project Summary

San Antonio Transfer Station Texas Regional Landfill Company LP Bexar County, Texas

Introduction

Weaver Consultants Group, LLC is in the process of developing a Type V municipal solid waste (MSW) transfer station registration application for the proposed San Antonio Transfer Station (TS) on behalf of Texas Regional Landfill Company, LP (TRLIC).

The proposed San Antonio TS will provide waste disposal services for the City of San Antonio, its residents, businesses and the surrounding areas. The proposed TS will provide TRLIC with the ability to collect, load, and transport solid waste more efficiently by allowing the MSW collection vehicles to transfer MSW into large transfer trailers before shipment to other permitted MSW landfills.

The purpose of this application is to permit the development of the San Antonio TS which will process up to a permitted daily rate of 125 ton per day of MSW from the City of San Antonio, Bexar County, its residents, businesses and surrounding areas, and transfer this waste to a TCEQ-permitted MSW landfill. The facility's application will undergo a thorough technical review by the TCEQ before obtaining authorization to operate.

The proposed TS structure will consist of a 130-foot by 150-foot tipping floor (where incoming waste will be unloaded and transferred to waste transfer trailers). The facility is proposed to have a permitted rate of waste acceptance of 125 tpd of MSW. This summary provides an overview of the proposed TS. The following subsections detail information regarding the owner and operator of the site, general site information, and a summary of the proposed site design.

Owner/Operator Information

The San Antonio TS will be owned and operated by TRCL, a subsidiary of Waste Connections Inc., (WC). WC is one of the leading providers of solid waste services in North America. WC is an integrated solid waste services company that acquires, operates, and provides non-hazardous waste collection, transfer, recycling, and disposal services to residential, municipal, and commercial customers across the continental United States and southern Canada.

Site Information

The following drawings are attached to this summary.

- Site Location Map (Figure 1). This figure shows the site location on a standard Texas Department of Transportation Bexar County highway map.
- General Topographic Map (Figure 2). This figure shows the site location on a United States Geological Survey (USGS) map.
- Aerial Photograph (Figure 3). This figure shows the existing conditions of the site on an aerial photograph.
- Proposed Site Plan (Figure 4). This figure shows the proposed site plan for the TS.

The San Antonio TS will be located within the city limits on the east side of San Antonio in Bexar County, Texas. The site will be accessed from FM 1346, which is approximately 3.7 miles south of the intersection of Interstate 10 and FM 1604 and then 1.5 miles west of intersection of FM 1604 and FM 1346. The service area will include the City of San Antonio residents, businesses and surrounding rural areas.

Design Summary

The following information presents a summary of the design and operations for the San Antonio TS.

- The TS will be open on two sides and will consist of a steel-framed structure with a metal roof and partial siding on two sides. The proposed transfer capacity of the facility is 125 tpd of MSW. Incoming loads will be directed to the tipping floor for transfer operations. The TS area will consist of a well-lit tipping floor (via natural lighting and overhead lighting) where transfer operations from collection vehicles to transfer trailers will occur. MSW transfer operations will occur completely underneath the structure. MSW unloaded on the tipping floor within the TS will typically be pushed by front-end loaders to a grapple loader (or similar materials handling equipment), which will load the MSW into a transfer trailer. The grapple loader may also be used to compact the waste or more evenly distribute the waste within the transfer trailer. The transfer trailer will haul the MSW to a properly permitted Type I MSW landfill.
- Upon issuance of the required TCEQ authorization, the TS will accept MSW, construction and demolition wastes, special wastes, wood waste, green waste, recyclables and non-hazardous industrial waste as allowed by the TCEQ regulations.
- Once approved by the TCEQ, the facility will be operated in accordance with the TCEQ-approved site operating plan. This plan includes procedures that govern day-to-day operations of the facility as well as routine inspections and housekeeping to ensure compliance with the TCEQ regulations. As part of the

operations, litter, dust, and odor control measures and procedures will be implemented.

- Access to the TS will be provided via the existing driveways located on the south side of FM 1346 Road. Employees and visitors will use the west driveway. Vehicles bound for the tipping floor will use the expanded east driveway. All vehicles bound for the TS will be directed to access the site using the FM 1346 Road route. From FM 1604 Road, vehicles will travel west on FM 1346 Road for approximately 1.6 miles to the site entrance. The existing roads are suitable to handle the projected traffic load associated with the TS.
- Properly trained personnel will operate the TS, and TRLC will staff the facility in the future based on the personnel needs to effectively serve the community. A detailed site operating plan will be included in the transfer station application. The plan will provide details on the required equipment, personnel, and safety procedures necessary to operate the facility in accordance with TCEQ regulations. The San Antonio TS will be inspected by the TCEQ on a regular basis to ensure the site is in compliance with state regulations.

0:\0601\12\TYPE V APPLICATION\PROJECT SUMMARY\FIG 3-AERIAL PHOTOGRAPH.dwg, mbohmmuni, 1:2

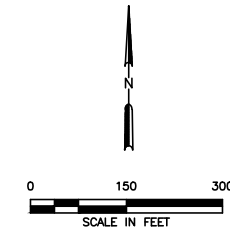

LEGEND
 --- REGISTRATION BOUNDARY

NOTES:

1. AERIAL PHOTOGRAPH PROVIDED BY GOOGLE EARTH DATED AUGUST 09, 2022.
2. ALL STRUCTURES WITHIN 500 FEET OF THE PERMIT BOUNDARY ARE SHOWN ON THIS FIGURE.

Tech. Complete App. - 152

<input type="checkbox"/> DRAFT <input checked="" type="checkbox"/> FOR PERMITTING PURPOSES ONLY <input type="checkbox"/> ISSUED FOR CONSTRUCTION	PREPARED FOR TEXAS REGIONAL LANDFILL COMPANY, LP		TYPE V REGISTRATION APPLICATION AERIAL PHOTOGRAPH														
	DATE: 07/2023 FILE: 0601-012-11 CAD: FIG 3-AERIAL PHOTOGRAPH.DWG		DRAWN BY: RAA DESIGN BY: MB REVIEWED BY: CRM														
Weaver Consultants Group TBPE REGISTRATION NO. F-3727		REVISIONS <table border="1"> <thead> <tr> <th>NO.</th> <th>DATE</th> <th>DESCRIPTION</th> </tr> </thead> <tbody> <tr> <td> </td> <td> </td> <td> </td> </tr> <tr> <td> </td> <td> </td> <td> </td> </tr> <tr> <td> </td> <td> </td> <td> </td> </tr> </tbody> </table>		NO.	DATE	DESCRIPTION										SAN ANTONIO TRANSFER STATION BEXAR COUNTY, TEXAS	
NO.	DATE	DESCRIPTION															
WWW.WCGRP.COM		FIGURE 3															

I/IIA-56

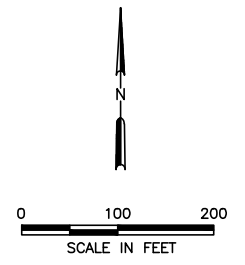

LEGEND

	REGISTRATION BOUNDARY
	EXISTING CONTOUR
	PROPOSED BUILDING
	EXISTING GRAVEL PAVEMENT
	PROPOSED GRAVEL PAVEMENT
	50-FOOT BUFFER ZONE
	ACCESS CONTROL FENCE (SEE NOTE 3)
	PROPOSED OPERATIONS AREA FENCE (SEE NOTE 2)

- NOTES:**
1. THE EXISTING CONTOURS PROVIDED BY TEXAS RESOURCE INFORMATION SYSTEM (TNRIS) BEXAR AND TRAVIS COUNTIES LIDAR, 2022.
 2. THE TRANSFER STATION ACCESS WILL BE CONTROLLED BY A FENCE AROUND THE PROPERTY WITH GATES ON THE FACILITY ENTRANCE ROAD. THE EXISTING 4-FOOT TALL BARBED WIRE FENCE COINCIDES WITH THE PROPERTY BOUNDARY. IN ADDITION TO THE EXISTING FENCE, AREAS WITH DENSE TREES PROVIDE A NATURAL BARRIER AROUND THE MAJORITY OF THE FACILITY BOUNDARY.
 3. PERIMETER FENCE ACCESS POINTS MAY BE INSTALLED TO FACILITATE SITE MAINTENANCE AND OPERATIONS.

O:\0601\12\TYPE V APPLICATION\PROJECT SUMMARY\FIG 4-PROPOSED SITE PLAN.dwg, mbahmani, 1:2

Tech. Complete App. - 153

<input type="checkbox"/> 90% REVIEW <input checked="" type="checkbox"/> FOR PERMITTING PURPOSES ONLY <input type="checkbox"/> ISSUED FOR CONSTRUCTION	PREPARED FOR TEXAS REGIONAL LANDFILL COMPANY, LP		TYPE V REGISTRATION APPLICATION PROPOSED SITE PLAN SAN ANTONIO TRANSFER STATION BEXAR COUNTY, TEXAS			
	DATE: 07/2023 FILE: 0601-012-11 CAD: FIG 4-PROPOSED SITE PLAN.DWG	DRAWN BY: RAA DESIGN BY: MB REVIEWED BY: CRM			REVISIONS	
Weaver Consultants Group TBPE REGISTRATION NO. F-3727		NO.	DATE	DESCRIPTION	WWW.WCGRP.COM	FIGURE 4

COORDINATION WITH ALAMO AREA COUNCIL OF GOVERNMENTS

CONTENTS

- April 23, 2024, AACOG Approval Letter
- February 15, 2024, AACOG Conformance Review Request Letter

APRIL 23, 2024 ACOG APPROVAL LETTER



2024 Board of Directors

- Rob Kelly, Chair**
County Judge, Kerr County
- Mary Dennis, Vice Chair**
Mayor, City of Live Oak
- Tommy Calvert**
Commissioner, Bexar County
- Rochelle Camacho**
County Judge, Frio County
- Rebeca Clay-Flores**
Commissioner, Bexar County
- Weldon Cude**
County Judge, Atascosa County
- Suzanne de Leon**
Mayor, City of Balcones Heights
- Donna Dodgen**
Mayor, City of Seguin
- Richard A. Evans**
County Judge, Bandera County
- Judy Eychner**
Mayor, City of Kerrville
- Dr. Adriana Rocha Garcia**
Councilwoman, City of San Antonio
- Marina Alderete Gavito**
Councilwoman, City of San Antonio
- James Hasslocher**
Board Member, University Health System
- Wade Hedtke**
County Judge, Karnes County
- Daniel Jones**
County Judge, Gillespie County
- Sherman Krause**
County Judge, Comal County
- Kyle Kutscher**
County Judge, Guadalupe County
- Lisa Lewis**
Chief Administrative Officer, CPS Energy
- Keith Lutz**
County Judge, Medina County
- Jose Menendez**
Senator, State of Texas, District 26
- Grant Moody**
Commissioner, Bexar County
- Andrew Murr**
State Representative, District 53
- Manny Pelaez**
Councilman, City of San Antonio
- Darrin Schroeder**
Mayor, City of Castroville
- Lawrence Spradley**
Councilman, City of New Braunfels
- Shane Stolarczyk**
County Judge, Kendall County
- James E. Teal**
County Judge, McMullen County
- Sylvester Vasquez**
President, Southwest ISD
- Enrique Valdivia**
Chair, Edwards Aquifer Authority
- Hank Whitman**
County Judge, Wilson County
- John Williams**
Mayor, City of Universal City
- Ryan Guillen (Ex-Officio)**
State Representative, District 31
- Brian Hoffman (Ex-Officio)**
Joint Base San Antonio
- John Kuempel (Ex-Officio)**
State Representative, District 44
- Judith Zaffirini (Ex-Officio)**
State Senator, District 21

April 23, 2024

Michael O'Malley
Texas Commission on Environmental Quality (TCEQ)
Business & Program Services, Waste Permits Division
Building F
12100 Park 35 Circle
Austin, Texas 78753

Re: Conformance Letter for Type V MSW Permit Application for Proposed San Antonio Transfer Station located at 10244 FM 1346 in Adkins Texas 78101, east of San Antonio, Bexar County Texas

Dear Mr. O'Malley:

After a review of the request to the Alamo Area Council of Governments (AACOG) Resource Recovery Committee (RRC) regarding the Conformance Letter for the Type V MSW Permit Application for Proposed San Antonio Transfer Station located at 10244 FM 1346 in Adkins, Texas 78101 east of San Antonio, Bexar County Texas and its compliance with the AACOG Regional Solid Waste Management Plan (RSWMP), the Resource Recovery Committee (RRC) has determined that the proposed Type V Transfer Station is in compliance with the AACOG RSWMP. The RRC recommended to the AACOG Board of Directors the approval of the San Antonio Type V Transfer Station's compliance with the AACOG RSWMP, and that a letter of compliance be sent to the Texas Commission on Environmental Quality (TCEQ) stating so.

The AACOG Board of Directors accepted the RRC's recommendation on March 27, 2024.

If you have any questions regarding this matter, please do not hesitate to contact Shauna Duff at (210) 362-5243 or Claudia Mora at (210) 918-1284.

Sincerely,

DocuSigned by:
Clifford C. Herberg 4/25/2024
F72AC8719DD049F...

Clifford C. Herberg
Executive Director

**FEBRUARY 15, 2024, ACOG CONFORMANCE
REVIEW REQUEST LETTER**



Project No. 0601-012-11-01
February 15, 2024

Mr. Tommy Calvert
Commissioner Precinct 4
101 W. Nueva, Suite 1029
San Antonio, Texas 782

Re: AACOG Conformance Review
San Antonio Transfer Station
Bexar County, Texas

Dear Mr. Calvert:

The purpose of this letter, submitted on behalf of Texas Regional Landfill Company, LP (TRLIC), is to coordinate with the Alamo Area Council of Governments (AACOG), consistent with Title 30 TAC §330.61(i)(4) regarding a proposed transfer station in Bexar county. In order for the applicant to coordinate with the AACOG, they are required to first notify their precinct commissioner of Bexar County of the proposed project.

Weaver Consultants Group, LLC, on behalf of TRLIC, has developed this package to summarize the Type V MSW Permit Application, for the proposed San Antonio Transfer Station (TS). The site will be located at 10244 FM 1346, Adkins, TX 78101, east of San Antonio, Bexar County, Texas.

The proposed San Antonio TS will provide waste disposal services for the City of San Antonio, its residents, businesses, and the surrounding areas. The proposed TS will provide TRLIC the ability to collect, process, load, and transport solid waste more efficiently by allowing solid waste collection vehicles to transfer the solid waste into large transfer trailers before shipment to a permitted MSW landfill.

To assist you in your review, a project summary and site location maps have been provided as an overview of the TS.

Please call if you have any questions or need additional information.

Mr. Tommy Calvert

February 15, 2024

Sincerely,

Weaver Consultants Group, LLC



Charles R. Marsh, P.E.
Project Director

Attachment: Project Summary and Site Location Maps.

cc: Gary Bartels, Waste Connections, Inc.
Dillon Hoppe, Waste Connections, Inc.

PLAN CONFORMANCE REVIEW INSTRUCTIONS

Note: This process is not a regulatory technical review of the application, and the COG does not approve or deny permit applications. Approval of municipal solid waste management permit applications are the responsibility of the TCEQ.

The Texas Commission on Environmental Quality (TCEQ) has directed the COG to evaluate whether a proposed municipal solid waste facility application is in conformance with the COG's regional plan. The regional plan is the 2022 – 2042 Regional Solid Waste Management Plan (RSWMP). It outlines the region's solid waste goals, objectives, and action steps during this 20-year period. The region's plan encourages collaboration, communication, education, information tracking, and leadership.

The purpose of this Regional Goal Conformance form is to provide guidance to the Resource Recovery Committee for their review process. The proposed facility's compliance to the region's plan will be based on the factors identified in this form.

The applicant is required to complete two sections:

- For each goal, the Conformance Questionnaire first describes each regional goal and objective. Then, there is a table for the goal, objectives, and action steps, each in the form of a yes or no question. Next to each action step write *Yes* if the proposed facility will help address that action item or *No* if it will not.
- In the Description of Conformance Activities section, for each action step where *Yes* was indicated, provide a description of how the proposed facility will contribute to that action step, keeping in mind the region's encouragement of collaboration, communication, education, information tracking, and leadership.

CONFORMANCE QUESTIONNAIRE

Goal 1: Maximize Beneficial Resource Use

The regional goal for Maximize Beneficial Resource Use includes ideas like recycling, composting, and reusing. For this goal, there are three objectives:

- **1.A.** Improve access to diversion opportunities,
- **1.B.** Improve community participation, and
- **1.C.** Provide education.

To help you understand these objectives: (1A) is about improving access, making it easier to participate, (1B) is about improving that community participation and getting more people involved, and (1C) is about providing education to ensure people understand how and why they should participate. These objectives build on and reinforce each other. For example, there is not much use to educating people on how to recycle if there are minimal opportunities to recycle.

Goal 1: Maximize beneficial resource use				
Objective		Action step		Yes/No
1.A.	Improve access to diversion opportunities	1.A.1.	Does your proposal identify and share a comprehensive list of locations to divert materials from the landfill?	No
		1.A.2.	Does your proposal encourage government agencies to lead by example in waste diversion and environmentally friendly procurement practices?	No
		1.A.3.	Does your proposal explore innovative waste collection and processing methods?	Yes
		1.A.4.	Does your proposal continue and expand the composting of biosolids and organic wastes?	No
		1.A.5.	Does your proposal encourage cities and counties to offer free cardboard recycling to businesses and explore free recycling for additional high-value commodities at other large-volume generators?	No
		1.A.6.	Does your proposal encourage the expansion of the ReWorksSA Certification Program throughout the region, including encouraging waste reduction?	No
		1.A.7.	Does your proposal explore innovative ways to increase the volume of materials diverted?	Yes
		1.A.8.	Does your proposal encourage exploration of opportunities to divert construction and demolition materials from landfills?	Yes
1.B.	Improve community participation	1.B.1.	Does your proposal outreach to large-volume generators with existing programs to consider accepting community-generated materials?	No
		1.B.2.	Does your proposal explore the potential for an online network to foster business-to-business connections to match by-products or surplus materials with opportunities for reuse or recycling?	No
		1.B.3.	Does your proposal outreach to community, civic, and school/university groups to provide volunteers for collection event activities?	Yes
1.C.	Provide education	1.C.1.	Does your proposal ensure broad public awareness using cost-effective communication tools including social media; COG, city, and county websites; and print materials, where appropriate, to provide consistent, reliable communication?	Yes

Goal 1: Maximize beneficial resource use				
Objective		Action step		Yes/No
		1.C.2	Does your proposal support sharing audience-specific information to educate target audiences on source reduction, recycling, reuse, or composting opportunities?	No

For each action step in Goal 1 for which you checked Yes, describe the services you can provide to assist with meeting this regional goal:

This facility will provide efficient and low-impact means of transferring solid waste. The transfer station’s design is flexible enough to allow for incorporation of new and more efficient means of solid waste collection and transfer.

Market factors will generally dictate the amount of C&D waste delivered to the proposed transfer station. The facility will consider transferring to a C&D landfill if that becomes a feasible option.

Lealco, Inc. is a subsidiary of Waste Connections, who make it a point to be involved in the communities they serve, including supporting local charities and businesses, promoting special collection events, and being active on social media in the area.

Goal 2: Responsibly manage problematic waste					
Objective		Action step			Yes/No
2.A.	Improve access to problematic waste collection	2.A.1.	Does your proposal encourage cities and counties to request information about on-demand curbside special waste collection?	No	
		2.A.2.	Does your proposal explore creating reuse opportunities?	No	
		2.A.3.	Does your proposal organize a region-wide scrap tire collection initiative?	No	
		2.A.4.	Does your proposal support local problematic waste collections events and explore developing region-wide collection events?	Yes	
2.B.	Provide education	2.B.1.	Does your proposal identify businesses where problematic wastes can be dropped off throughout the region?	No	
		2.B.2.	Does your proposal ensure broad public awareness using cost-effective communication tools including social media; COG, city, and county websites; and print materials, where appropriate, to provide consistent, reliable communication?	Yes	

		2.B.3.	Does your proposal leverage collection events to increase understanding of problematic waste by providing information to the media and local champions, and providing information to event participants—including print materials where appropriate?	No
2.C.	Collect data	2.C.1.	Does your proposal collect, analyze, and share data to improve future events?	No

For each action step in Goal 2 for which you checked *Yes*, describe the services you can provide to assist with meeting this regional goal:

As noted above, Lealco, Inc. will support regional collection events and be using social media to communicate with the service area.

Goal 3: Maximize proper disposal				
Objective		Action step		Yes/No
3.A.	Improve access to solid waste drop-off opportunities	3.A.1.	Does your proposal support and expand reduced-cost options for waste disposal?	Yes
		3.A.2.	Does your proposal share best practices for and promote establishment of additional municipal and county collection centers?	No
		3.A.3.	Does your proposal explore ways to expand curbside trash collection in currently underserved areas?	No
3.B.	Improve community participation	3.B.1.	Does your proposal support programs that encourage and enable community illegal dumping reporting?	No
		3.B.2.	Does your proposal support local community clean up events and encourage organizers to seek funding from business and civic partners, share best practices with other local organizers and recruit volunteers from schools and other community organizations?	Yes
3.C.	Provide education	3.C.1.	Does your proposal ensure broad public awareness using cost-effective communication tools including social media and the websites of each relevant city and county to provide consistent, reliable communication?	Yes
		3.C.2.	Does your proposal leverage cleanup events to increase understanding of illegal dumping by providing information to the media and local champions, and providing information to cleanup participants—including print materials where appropriate?	No
		3.C.3.	Does your proposal educate and engage targeted segments of the community on proper disposal methods and the impact of illegal dumping?	No

Goal 3: Maximize proper disposal				
Objective		Action step		Yes/No
3.D.	Collect data	3.D.1.	Does your proposal encourage collection and analysis of illegal dumping data?	No
3.E.	Increase illegal dumping prevention efforts	3.E.1.	Does your proposal support deterrents such as surveillance cameras, simple signage, beautification, and fencing in high-incident areas as part of a comprehensive illegal dumping strategy, which includes prevention, abatement, education, and enforcement?	Yes
3.F.	Improve illegal dumping enforcement	3.F.1.	Does your proposal outreach to prosecutors and judges to increase their support of illegal dumping enforcement?	No
		3.F.2.	Does your proposal continue exploring establishment of a Regional Environmental Task Force to share emerging illegal dumping issues, lessons learned, and best practices?	Yes
		3.F.3.	Does your proposal support training for enforcement officers and judges?	No

For each action step in Goal 3 for which you checked *Yes*, describe the services you can provide to assist with meeting this regional goal:

The transfer station will provide an economical alternative to residents and businesses to drop off acceptable waste material rather than travel farther to a permitted landfill.

Lealco and Waste Connections are dedicated to reducing illegal dumping in their service areas and will be supporting clean up efforts as well as providing another location for waste to be safely and legally dropped off for disposal. Additionally, the facility will support a Regional Task Force focusing on illegal dumping.

As noted above, Lealco, Inc. will be using social media to communicate with the service area.

Within the property, secured access, signage, cameras, and site personnel will be utilized to ensure waste is processed properly.

Note: To make sure you are familiar with the entire plan, Goal 4 has been similarly adapted for this form for informational purposes only.

Goal 4: Lead Regional Planning			
Objective		Action steps	
4.A.	Collaborate	4.A.1.	Does your proposal initiate annual Solid Waste Management Award program for cities, counties, businesses, and individuals within the region?
		4.A.2.	Does your proposal compile a master list of all materials collected for recycling, composting, or reuse by cities and counties within the region and look for opportunities to harmonize collections to minimize confusion?
		4.A.3.	Does your proposal share the Regional Solid Waste Management Plan with relevant local decision makers to increase awareness, encourage participation, and maximize benefits?
		4.A.4.	Does your proposal encourage the development of local solid waste management plans for cities and counties to implement the relevant goals 1-3 in this plan for their communities?
		4.A.5.	Does your proposal utilize and customize existing resources and tools where possible to create consistency and save time and money?
4.B.	Optimize funding decisions	4.B.1.	Does your proposal continue to use COG pass-through grant funding criteria that encourages participation in committee activities and ensures alignment with regional waste management priorities?
		4.B.2.	Does your proposal apply for external grant funding to supplement available TCEQ funds to enable broader implementation of the Regional Solid Waste Management Plan?
4.C.	Oversee facility planning	4.C.1.	Does your proposal evaluate Municipal Solid Waste facility permit applications?
		4.C.2.	Does your proposal ensure adequate regional waste disposal capacity?
		4.C.3.	Does your proposal maintain the closed landfill inventory?
4.D.	Review and update solid waste management plans	4.D.1.	Does your proposal update the Regional Solid Waste Management Plan as necessary?
		4.D.2.	Does your proposal publish biennial status reports of regional solid waste management plan goal progress and accomplishments?

Goal 4: Lead Regional Planning			
Objective		Action steps	
4.E.	Make continuous improvements	4.E.1.	Does your proposal stay informed about changing solid waste management best practices and technologies?
4.F.	Collect data	4.F.1.	Does your proposal explore developing a regional data sharing platform which could be used by cities and counties within the COG to help with solid waste planning?
4.G.	Plan for disaster waste	4.G.1	Does your proposal encourage development of local disaster debris management plans?
		4.G.2.	Does your proposal create peer exchange opportunities to share best practices and existing resources for local disaster debris managements plans?

Please provide any additional details you would like the Committee to consider:

APPENDIX I/IIB

**AREA WATER WELL INFORMATION
PERFORMED BY ERIS**



Property Information

Order Number:	23020600750p
Date Completed:	February 7, 2023
Project Number:	WCI-SA-TS
Project Property:	10244 FM 1346 10244 FM 12244 Adkins TX 78101
Coordinates:	
Latitude:	29.41866826
Longitude:	-98.28578201
UTM Northing:	3254584.03611 Meters
UTM Easting:	569283.544125 Meters
UTM Zone:	UTM Zone 14R
Elevation:	638.02 ft
Slope Direction:	SE

Topographic Information.....	2
Hydrologic Information.....	4
Geologic Information.....	7
Soil Information.....	9
Pipeline and Survey Map.....	19
Wells and Additional Sources.....	21
Summary.....	22
Detail Report.....	25
Radon Information.....	29
Appendix.....	30
Liability Notice.....	33

The ERIS **Physical Setting Report - PSR** provides comprehensive information about the physical setting around a site and includes a complete overview of topography and surface topology, in addition to hydrologic, geologic and soil characteristics. The location and detailed attributes of oil and gas wells, water wells, public water systems and radon are also included for review.

The compilation of both physical characteristics of a site and additional attribute data is useful in assessing the impact of migration of contaminants and subsequent impact on soils and groundwater.

Disclaimer

This Report does not provide a full environmental evaluation for the site or adjacent properties. Please see the terms and disclaimer at the end of the Report for greater detail.

Topographic Information

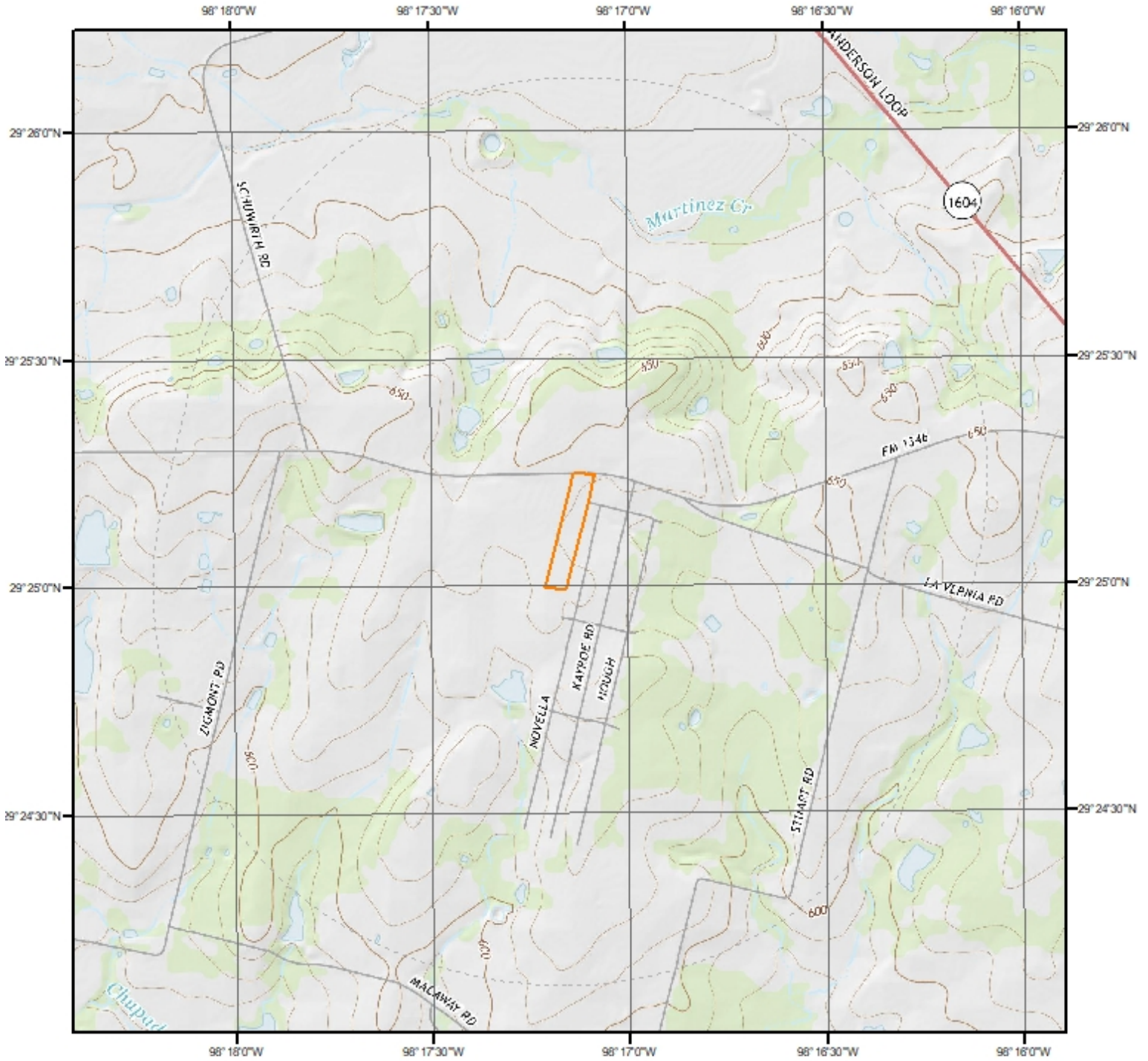

Current USGS Topo (2016)

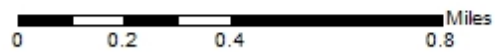

Quadrangle(s): Martinez, TX

Source: USGS 7.5 Minute Topographic Map



Topographic Information

The previous topographic map(s) are created by seamlessly merging and cutting current USGS topographic data. Below are shaded relief map(s), derived from USGS elevation data to show surrounding topography in further detail.

Topographic information at project property:

Elevation: 638.02 ft
Slope Direction: SE

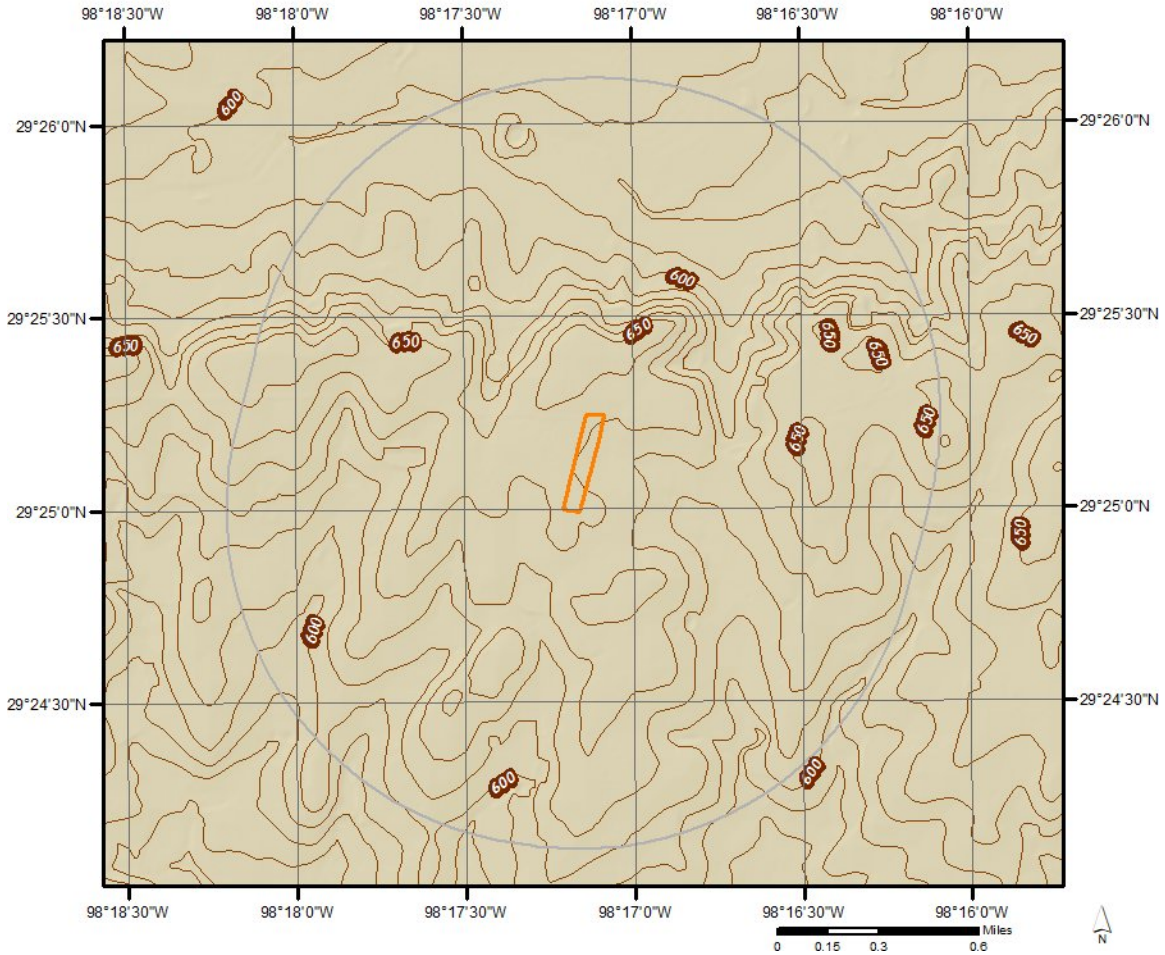

Hydrologic Information



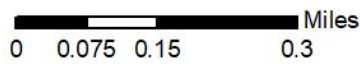

Source: Esri, Maxar, Earthstar Geographics, and the GIS User Community

Wetland



This map shows wetland existence using data from US Fish & Wildlife. Data coverage is shown to the right. Gray indicates no data available in the area.

- | | |
|---|---|
|  Estuarine and Marine Deepwater |  Freshwater Pond |
|  Estuarine and Marine Wetland |  Lake |
|  Freshwater Emergent Wetland |  Other |
|  Freshwater Forested/Shrub Wetland |  Riverine |



Hydrologic Information

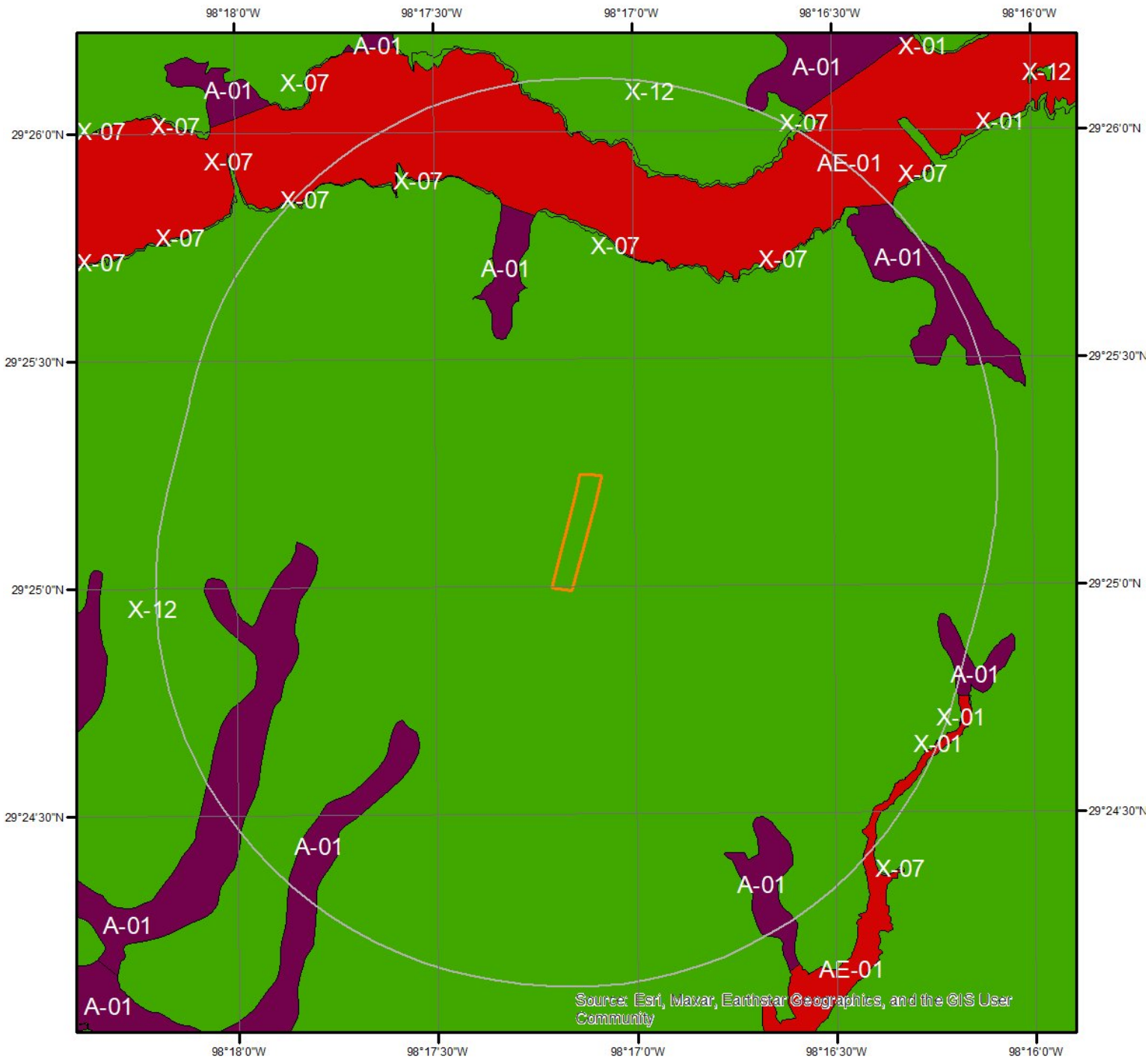

Flood Hazard Zones

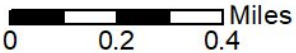

This map shows FEMA flood hazard zones. FIRM panels are shown to the right, and blank indicates no data is available.

- | | | |
|---|--|---|
| A | AO | X |
| A99 | V | OPEN WATER |
| AE | VE | NOT POPULATED |
| AH | D | AREA NOT INCLUDED |

Quadrangle(s): Martinez, TX

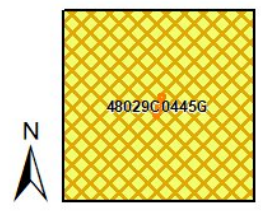

Hydrologic Information

The Wetland Type map shows wetland existence overlaid on an aerial imagery. The Flood Hazard Zones map shows FEMA flood hazard zones overlaid on an aerial imagery. Relevant FIRM panels and detailed zone information is provided below. For detailed Zone descriptions please click the link: <https://floodadvocate.com/fema-zone-definitions>

Available FIRM Panels in area: 48029C0445G(effective:2010-09-29)

Flood Zone A-01

Zone: A
Zone subtype:

Flood Zone AE-01

Zone: AE
Zone subtype:

Flood Zone X-01

Zone: X
Zone subtype: 0.2 PCT ANNUAL CHANCE FLOOD HAZARD

Flood Zone X-07

Zone: X
Zone subtype: 1 PCT FUTURE CONDITIONS

Flood Zone X-12

Zone: X
Zone subtype: AREA OF MINIMAL FLOOD HAZARD

Geologic Information

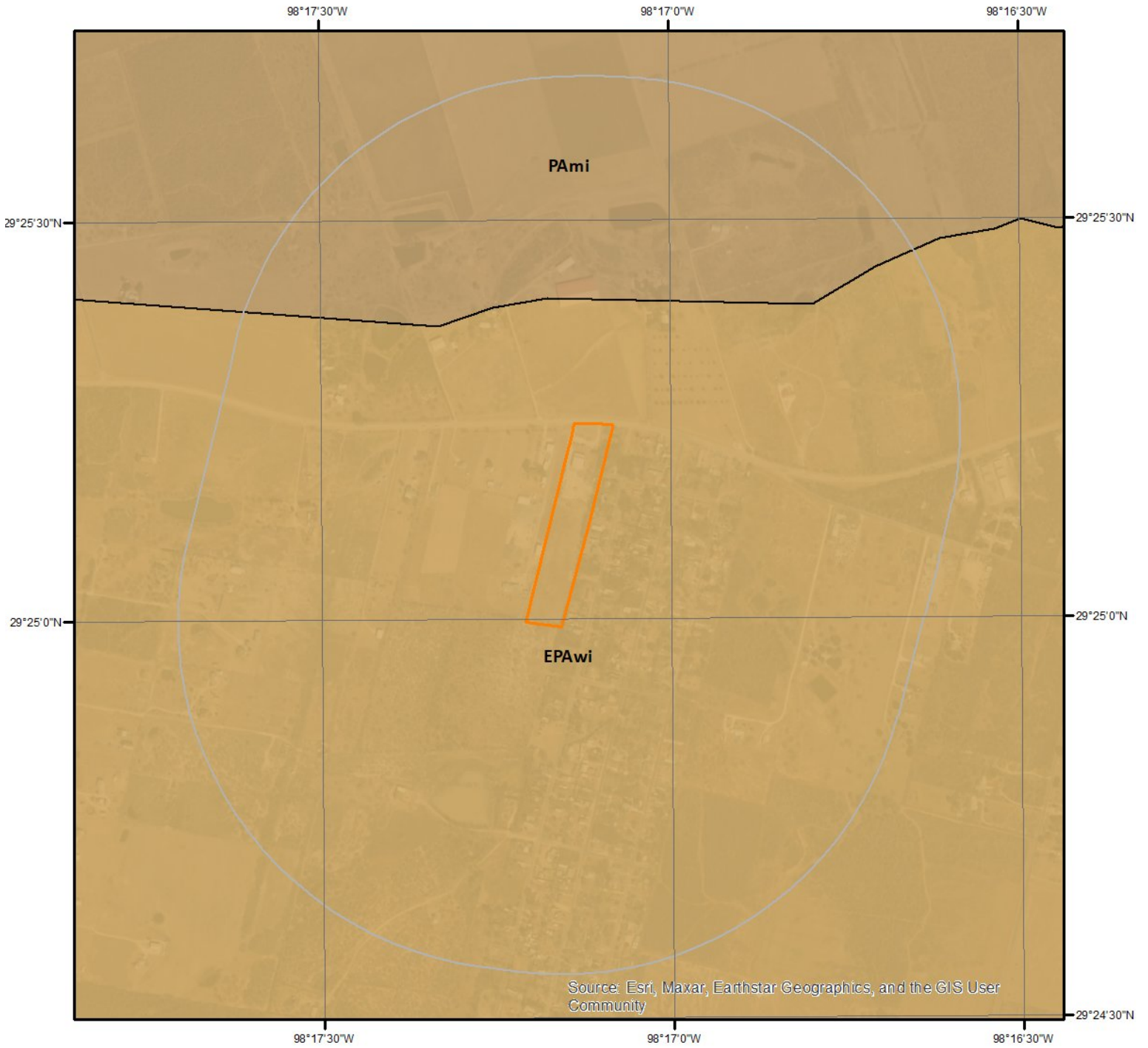

Geologic Units

This map shows geologic units in the area. Please refer to the report for detailed descriptions.

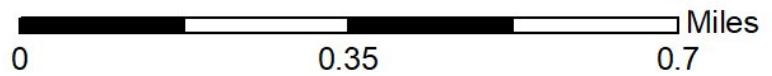
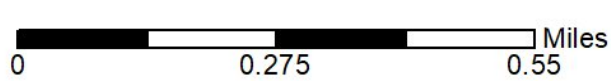

Geologic Information

The previous page shows USGS geology information. Detailed information about each unit is provided below.

Geologic Unit EPAwi

Unit Name:	Wilcox Group, undivided
Unit Age:	Phanerozoic Cenozoic Tertiary Paleocene Eocene
Primary Rock Type:	fine-grained mixed clastic
Secondary Rock Type:	coal
Unit Description:	Wilcox Group, undivided

Geologic Unit PAmi

Unit Name:	Midway Group, undivided
Unit Age:	Phanerozoic Cenozoic Tertiary Paleocene
Primary Rock Type:	fine-grained mixed clastic
Secondary Rock Type:	limestone
Unit Description:	Midway Group, undivided

Soil Information

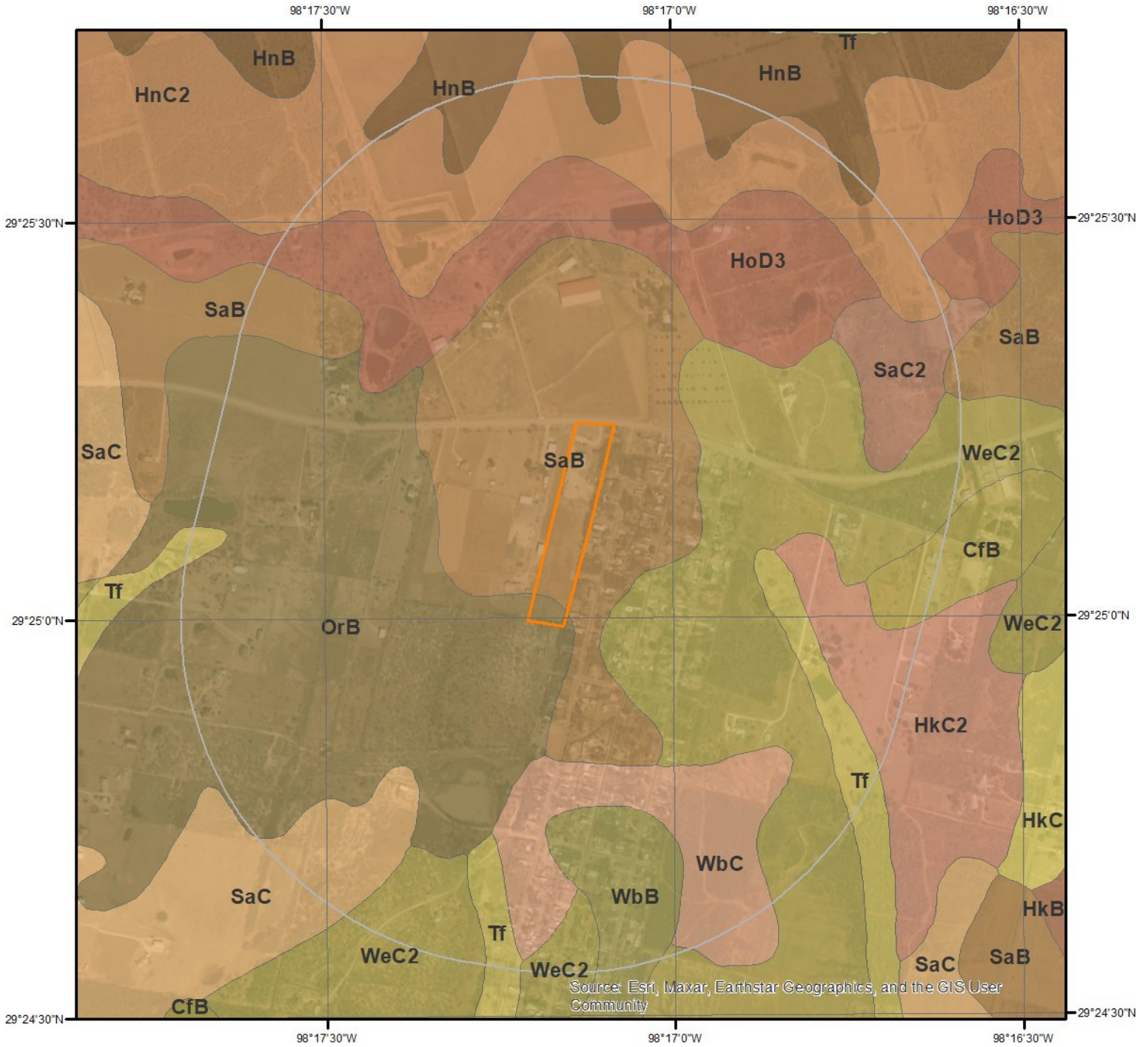

SSURGO Soils



This maps shows SSURGO soil units around the target property. Please refer to the report for detailed soil descriptions.



Soil Information

The previous page shows a soil map using SSURGO data from USDA Natural Resources Conservation Service. Detailed information about each unit is provided below.

Map Unit CfB (0.72%)

Map Unit Name:	Miguel fine sandy loam, 1 to 3 percent slopes
Bedrock Depth - Min:	null
Watertable Depth - Annual Min:	null
Drainage Class - Dominant:	Well drained
Hydrologic Group - Dominant:	C - Soils in this group have moderately high runoff potential when thoroughly wet. Water transmission through the soil is somewhat restricted.

Major components are printed below

Miguel(95%)	
horizon A(0cm to 28cm)	Fine sandy loam
horizon Bt(28cm to 84cm)	Sandy clay
horizon Btk(84cm to 109cm)	Sandy clay loam
horizon BC(109cm to 203cm)	Sandy clay loam

Component Description:

Minor map unit components are excluded from this report.

Map Unit: CfB - Miguel fine sandy loam, 1 to 3 percent slopes

Component: Miguel (95%)

The Miguel component makes up 95 percent of the map unit. Slopes are 1 to 3 percent. This component is on low hills on inland, dissected coastal plains. The parent material consists of loamy and/or clayey residuum weathered from sandstone and/or mudstone. Depth to a root restrictive layer is greater than 60 inches. The natural drainage class is well drained. Water movement in the most restrictive layer is moderately low. Available water to a depth of 60 inches (or restricted depth) is moderate. Shrink-swell potential is moderate. This soil is not flooded. It is not ponded. There is no zone of water saturation within a depth of 72 inches. Organic matter content in the surface horizon is about 1 percent. This component is in the R083AY024TX Tight Sandy Loam ecological site. Nonirrigated land capability classification is 3e. Irrigated land capability classification is 3e. This soil does not meet hydric criteria. The calcium carbonate equivalent within 40 inches, typically, does not exceed 5 percent. There are no saline horizons within 30 inches of the soil surface. The soil has a maximum sodium adsorption ratio of 8 within 30 inches of the soil surface.

Component: Bryde (2%)

Generated brief soil descriptions are created for major soil components. The Bryde soil is a minor component.

Component: Wilco (2%)

Generated brief soil descriptions are created for major soil components. The Wilco soil is a minor component.

Component: Tiocano (1%)

Generated brief soil descriptions are created for major soil components. The Tiocano soil is a minor component.

Map Unit HkC2 (2.05%)

Map Unit Name:	Wilco loamy fine sand, 3 to 5 percent slopes, eroded
Bedrock Depth - Min:	null
Watertable Depth - Annual Min:	null
Drainage Class - Dominant:	Well drained
Hydrologic Group - Dominant:	C - Soils in this group have moderately high runoff potential when thoroughly wet. Water transmission through the soil is somewhat restricted.

Major components are printed below

Wilco(100%)	
horizon H1(0cm to 41cm)	Loamy fine sand
horizon H2(41cm to 84cm)	Sandy clay loam
horizon H3(84cm to 102cm)	Sandy clay loam

I/IIB-11

Soil Information

horizon H4(102cm to 152cm)

Sandy clay loam

Component Description:

Minor map unit components are excluded from this report.

Map Unit: HkC2 - Wilco loamy fine sand, 3 to 5 percent slopes, eroded

Component: Wilco (100%)

The Wilco, eroded component makes up 100 percent of the map unit. Slopes are 3 to 5 percent. This component is on interfluvial on inland, dissected coastal plains. The parent material consists of loamy fluviomarine deposits. Depth to a root restrictive layer is greater than 60 inches. The natural drainage class is well drained. Water movement in the most restrictive layer is moderately low. Available water to a depth of 60 inches (or restricted depth) is moderate. Shrink-swell potential is moderate. This soil is not flooded. It is not ponded. There is no zone of water saturation within a depth of 72 inches. Organic matter content in the surface horizon is about 1 percent. This component is in the R083AY022TX Loamy Sand ecological site. Nonirrigated land capability classification is 4e. Irrigated land capability classification is 4e. This soil does not meet hydric criteria. The calcium carbonate equivalent within 40 inches, typically, does not exceed 2 percent.

Map Unit HnB (22.24%)

Map Unit Name: Heiden clay, 1 to 3 percent slopes

Bedrock Depth - Min: null

Watertable Depth - Annual Min: null

Drainage Class - Dominant: Well drained

Hydrologic Group - Dominant: D - Soils in this group have high runoff potential when thoroughly wet. Water movement through the soil is restricted or very restricted.

Major components are printed below

Heiden(85%)

horizon Ap(0cm to 15cm) Clay

horizon A(15cm to 46cm) Clay

horizon Bkss(46cm to 147cm) Clay

horizon CBdk(147cm to 178cm) Clay

Component Description:

Minor map unit components are excluded from this report.

Map Unit: HnB - Heiden clay, 1 to 3 percent slopes

Component: Heiden (85%)

The Heiden component makes up 85 percent of the map unit. Slopes are 1 to 3 percent. This component is on ridges on dissected plains. The parent material consists of clayey residuum weathered from mudstone. Depth to a root restrictive layer, densic material, is 40 to 65 inches. The natural drainage class is well drained. Water movement in the most restrictive layer is low. Available water to a depth of 60 inches (or restricted depth) is high. Shrink-swell potential is very high. This soil is not flooded. It is not ponded. There is no zone of water saturation within a depth of 72 inches. Organic matter content in the surface horizon is about 3 percent. This component is in the R086AY011TX Southern Blackland ecological site. Nonirrigated land capability classification is 3e. This soil does not meet hydric criteria. The calcium carbonate equivalent within 40 inches, typically, does not exceed 14 percent. There are no saline horizons within 30 inches of the soil surface. The soil has a maximum sodium adsorption ratio of 7 within 30 inches of the soil surface.

Component: Houston Black (10%)

Generated brief soil descriptions are created for major soil components. The Houston Black soil is a minor component.

Component: Ferris (5%)

Generated brief soil descriptions are created for major soil components. The Ferris soil is a minor component.

Map Unit HnC2 (14.32%)

Map Unit Name: Heiden clay, 3 to 5 percent slopes, eroded

Bedrock Depth - Min: null

Soil Information

Watertable Depth - Annual Min: null
Drainage Class - Dominant: Well drained
Hydrologic Group - Dominant: D - Soils in this group have high runoff potential when thoroughly wet. Water movement through the soil is restricted or very restricted.

Major components are printed below

Heiden(85%)

horizon A(0cm to 33cm)	Clay
horizon Bss(33cm to 56cm)	Clay
horizon Bkss(56cm to 147cm)	Clay
horizon CBdk(147cm to 203cm)	Clay

Component Description:

Minor map unit components are excluded from this report.

Map Unit: HnC2 - Heiden clay, 3 to 5 percent slopes, eroded

Component: Heiden (85%)

The Heiden, moderately eroded component makes up 85 percent of the map unit. Slopes are 3 to 5 percent. This component is on ridges on dissected plains. The parent material consists of clayey residuum weathered from mudstone. Depth to a root restrictive layer, densic material, is 40 to 65 inches. The natural drainage class is well drained. Water movement in the most restrictive layer is low. Available water to a depth of 60 inches (or restricted depth) is high. Shrink-swell potential is very high. This soil is not flooded. It is not ponded. There is no zone of water saturation within a depth of 72 inches. Organic matter content in the surface horizon is about 3 percent. This component is in the R086AY009TX Southern Eroded Blackland ecological site. Nonirrigated land capability classification is 3e. This soil does not meet hydric criteria. The calcium carbonate equivalent within 40 inches, typically, does not exceed 14 percent. There are no saline horizons within 30 inches of the soil surface. The soil has a maximum sodium adsorption ratio of 7 within 30 inches of the soil surface.

Component: Houston Black (10%)

Generated brief soil descriptions are created for major soil components. The Houston Black soil is a minor component.

Component: Ferris (5%)

Generated brief soil descriptions are created for major soil components. The Ferris, severely eroded soil is a minor component.

Map Unit HoD3 (10.48%)

Map Unit Name: Heiden-Ferris complex, 5 to 10 percent slopes, severely eroded
Bedrock Depth - Min: 102cm
Watertable Depth - Annual Min: null
Drainage Class - Dominant: Well drained
Hydrologic Group - Dominant: D - Soils in this group have high runoff potential when thoroughly wet. Water movement through the soil is restricted or very restricted.

Major components are printed below

Heiden(75%)

horizon H1(0cm to 36cm)	Clay
horizon H2(36cm to 64cm)	Clay
horizon H3(64cm to 157cm)	Clay
horizon H4(157cm to 203cm)	Clay

Ferris(20%)

horizon H1(0cm to 20cm)	Clay
horizon H2(20cm to 102cm)	Clay
horizon H3(102cm to 213cm)	Clay

Component Description:

Minor map unit components are excluded from this report.

Map Unit: HoD3 - Heiden-Ferris complex, 5 to 10 percent slopes, severely eroded

Soil Information

Component: Heiden (75%)

The Heiden, severely eroded component makes up 75 percent of the map unit. Slopes are 5 to 10 percent. This component is on linear gilgai on ridges on dissected plains. The parent material consists of clayey residuum weathered from clayey shale of Eagleford Shale or Taylor Marl. Depth to a root restrictive layer is greater than 60 inches. The natural drainage class is well drained. Water movement in the most restrictive layer is low. Available water to a depth of 60 inches (or restricted depth) is moderate. Shrink-swell potential is very high. This soil is not flooded. It is not ponded. There is no zone of water saturation within a depth of 72 inches. Organic matter content in the surface horizon is about 3 percent. This component is in the R086AY009TX Southern Eroded Blackland ecological site. Nonirrigated land capability classification is 6e. This soil does not meet hydric criteria. The calcium carbonate equivalent within 40 inches, typically, does not exceed 30 percent. There are no saline horizons within 30 inches of the soil surface. The soil has a maximum sodium adsorption ratio of 7 within 30 inches of the soil surface.

Component: Ferris (20%)

The Ferris, severely eroded component makes up 20 percent of the map unit. Slopes are 5 to 15 percent. This component is on linear gilgai on ridges on dissected plains. The parent material consists of residuum weathered from calcareous shale in Eagleford Shale and Taylor Marl formations of Cretaceous age. Depth to a root restrictive layer, bedrock, densic, is 40 to 60 inches. The natural drainage class is well drained. Water movement in the most restrictive layer is low. Available water to a depth of 60 inches (or restricted depth) is moderate. Shrink-swell potential is very high. This soil is not flooded. It is not ponded. There is no zone of water saturation within a depth of 72 inches. Organic matter content in the surface horizon is about 1 percent. This component is in the R086AY009TX Southern Eroded Blackland ecological site. Nonirrigated land capability classification is 6e. This soil does not meet hydric criteria. The calcium carbonate equivalent within 40 inches, typically, does not exceed 16 percent. There are no saline horizons within 30 inches of the soil surface. The soil has a maximum sodium adsorption ratio of 1 within 30 inches of the soil surface.

Component: Unnamed (5%)

Generated brief soil descriptions are created for major soil components. The Unnamed soil is a minor component.

Map Unit OrB (7.71%)

Map Unit Name:	Laparita clay loam, 1 to 3 percent slopes
Bedrock Depth - Min:	null
Watertable Depth - Annual Min:	null
Drainage Class - Dominant:	Well drained
Hydrologic Group - Dominant:	C - Soils in this group have moderately high runoff potential when thoroughly wet. Water transmission through the soil is somewhat restricted.

Major components are printed below

Laparita(100%)	
horizon H1(0cm to 20cm)	Clay loam
horizon H2(20cm to 102cm)	Sandy clay
horizon H3(102cm to 183cm)	Clay

Component Description:

Minor map unit components are excluded from this report.

Map Unit: OrB - Laparita clay loam, 1 to 3 percent slopes

Component: Laparita (100%)

The Laparita component makes up 100 percent of the map unit. Slopes are 1 to 3 percent. This component is on broad interfluves on inland, dissected coastal plains. The parent material consists of clayey residuum weathered from shale. Depth to a root restrictive layer is greater than 60 inches. The natural drainage class is well drained. Water movement in the most restrictive layer is moderately high. Available water to a depth of 60 inches (or restricted depth) is low. Shrink-swell potential is high. This soil is not flooded. It is not ponded. There is no zone of water saturation within a depth of 72 inches. Organic matter content in the surface horizon is about 2 percent. This component is in the R083AY011TX Claypan Prairie ecological site. Nonirrigated land capability classification is 3e. Irrigated land capability classification is 3e. This soil does not meet hydric criteria. The calcium carbonate equivalent within 40 inches, typically, does not exceed 5 percent. The soil has a moderately saline horizon within 30 inches of the soil surface. The soil has a maximum sodium adsorption ratio of 7 within 30 inches of the soil surface.

Map Unit SaB (10.63%)

Map Unit Name:	San Antonio clay loam, 1 to 3 percent slopes
----------------	--

Soil Information

Bedrock Depth - Min:	null
Watertable Depth - Annual Min:	null
Drainage Class - Dominant:	Well drained
Hydrologic Group - Dominant:	C - Soils in this group have moderately high runoff potential when thoroughly wet. Water transmission through the soil is somewhat restricted.

Major components are printed below

San Antonio(100%)	
horizon H1(0cm to 25cm)	Clay loam
horizon H2(25cm to 97cm)	Clay
horizon H3(97cm to 152cm)	Clay loam

Component Description:

Minor map unit components are excluded from this report.

Map Unit: SaB - San Antonio clay loam, 1 to 3 percent slopes

Component: San Antonio (100%)

The San Antonio component makes up 100 percent of the map unit. Slopes are 1 to 3 percent. This component is on stream terraces on inland dissected coastal plains. The parent material consists of loamy alluvium of Quaternary age derived from mixed sources. Depth to a root restrictive layer is greater than 60 inches. The natural drainage class is well drained. Water movement in the most restrictive layer is moderately low. Available water to a depth of 60 inches (or restricted depth) is high. Shrink-swell potential is high. This soil is not flooded. It is not ponded. There is no zone of water saturation within a depth of 72 inches. Organic matter content in the surface horizon is about 1 percent. This component is in the R083AY026TX Eastern Clay Loam ecological site. Nonirrigated land capability classification is 2e. This soil does not meet hydric criteria. The calcium carbonate equivalent within 40 inches, typically, does not exceed 5 percent. There are no saline horizons within 30 inches of the soil surface.

Map Unit SaC (3.02%)

Map Unit Name:	San Antonio clay loam, 3 to 5 percent slopes
Bedrock Depth - Min:	null
Watertable Depth - Annual Min:	null
Drainage Class - Dominant:	Well drained
Hydrologic Group - Dominant:	C - Soils in this group have moderately high runoff potential when thoroughly wet. Water transmission through the soil is somewhat restricted.

Major components are printed below

San Antonio(100%)	
horizon H1(0cm to 15cm)	Clay loam
horizon H2(15cm to 71cm)	Clay
horizon H3(71cm to 152cm)	Clay loam

Component Description:

Minor map unit components are excluded from this report.

Map Unit: SaC - San Antonio clay loam, 3 to 5 percent slopes

Component: San Antonio (100%)

The San Antonio component makes up 100 percent of the map unit. Slopes are 3 to 5 percent. This component is on stream terraces on inland dissected coastal plains. The parent material consists of loamy alluvium of Quaternary age derived from mixed sources. Depth to a root restrictive layer is greater than 60 inches. The natural drainage class is well drained. Water movement in the most restrictive layer is moderately low. Available water to a depth of 60 inches (or restricted depth) is high. Shrink-swell potential is moderate. This soil is not flooded. It is not ponded. There is no zone of water saturation within a depth of 72 inches. Organic matter content in the surface horizon is about 1 percent. This component is in the R083AY026TX Eastern Clay Loam ecological site. Nonirrigated land capability classification is 3e. This soil does not meet hydric criteria. The calcium carbonate equivalent within 40 inches, typically, does not exceed 5 percent. There are no saline horizons within 30 inches of the soil surface.

Soil Information

Map Unit SaC2 (0.62%)

Map Unit Name:	San Antonio clay loam, 3 to 5 percent slopes, eroded
Bedrock Depth - Min:	null
Watertable Depth - Annual Min:	null
Drainage Class - Dominant:	Well drained
Hydrologic Group - Dominant:	C - Soils in this group have moderately high runoff potential when thoroughly wet. Water transmission through the soil is somewhat restricted.

Major components are printed below

San Antonio(100%)	
horizon H1(0cm to 10cm)	Clay loam
horizon H2(10cm to 61cm)	Clay
horizon H3(61cm to 152cm)	Clay loam

Component Description:

Minor map unit components are excluded from this report.

Map Unit: SaC2 - San Antonio clay loam, 3 to 5 percent slopes, eroded

Component: San Antonio (100%)

The San Antonio, eroded component makes up 100 percent of the map unit. Slopes are 3 to 5 percent. This component is on stream terraces on inland dissected coastal plains. The parent material consists of loamy alluvium of Quaternary age derived from mixed sources. Depth to a root restrictive layer is greater than 60 inches. The natural drainage class is well drained. Water movement in the most restrictive layer is moderately low. Available water to a depth of 60 inches (or restricted depth) is high. Shrink-swell potential is moderate. This soil is not flooded. It is not ponded. There is no zone of water saturation within a depth of 72 inches. Organic matter content in the surface horizon is about 1 percent. This component is in the R083AY026TX Eastern Clay Loam ecological site. Nonirrigated land capability classification is 4e. This soil does not meet hydric criteria. The calcium carbonate equivalent within 40 inches, typically, does not exceed 5 percent. There are no saline horizons within 30 inches of the soil surface.

Map Unit Tf (13.05%)

Map Unit Name:	Tinn and Frio soils, 0 to 1 percent slopes, frequently flooded
Bedrock Depth - Min:	null
Watertable Depth - Annual Min:	null
Drainage Class - Dominant:	Moderately well drained
Hydrologic Group - Dominant:	D - Soils in this group have high runoff potential when thoroughly wet. Water movement through the soil is restricted or very restricted.

Major components are printed below

Tinn(70%)	
horizon A(0cm to 46cm)	Clay
horizon Bss(46cm to 183cm)	Clay
horizon Bkssy(183cm to 203cm)	Clay
Frio(30%)	
horizon A1(0cm to 56cm)	Clay loam
horizon A2(56cm to 102cm)	Silty clay loam
horizon Bk(102cm to 203cm)	Silty clay

Component Description:

Minor map unit components are excluded from this report.

Map Unit: Tf - Tinn and Frio soils, 0 to 1 percent slopes, frequently flooded

Component: Tinn (70%)

The Tinn component makes up 70 percent of the map unit. Slopes are 0 to 1 percent. This component is on circular gilgai on flood plains on dissected plains. The parent material consists of calcareous clayey alluvium. Depth to a root restrictive layer is greater than 60 inches. The natural drainage class is moderately well drained. Water movement in the most restrictive layer is low. Available water to a depth of 60 inches (or restricted depth) is high. Shrink-swell potential is very high. This soil is frequently flooded. It is not

Soil Information

ponded. There is no zone of water saturation within a depth of 72 inches. Organic matter content in the surface horizon is about 3 percent. This component is in the R086AY013TX Clayey Bottomland ecological site. Nonirrigated land capability classification is 5w. Irrigated land capability classification is 5w. This soil does not meet hydric criteria. The calcium carbonate equivalent within 40 inches, typically, does not exceed 15 percent. There are no saline horizons within 30 inches of the soil surface.

Component: Frio (30%)

The Frio component makes up 30 percent of the map unit. Slopes are 0 to 1 percent. This component is on flood plains on dissected plains. The parent material consists of calcareous loamy and/or clayey alluvium. Depth to a root restrictive layer is greater than 60 inches. The natural drainage class is well drained. Water movement in the most restrictive layer is moderately low. Available water to a depth of 60 inches (or restricted depth) is high. Shrink-swell potential is high. This soil is frequently flooded. It is not ponded. There is no zone of water saturation within a depth of 72 inches. Organic matter content in the surface horizon is about 3 percent. This component is in the R086AY012TX Loamy Bottomland ecological site. Nonirrigated land capability classification is 5w. Irrigated land capability classification is 5w. This soil does not meet hydric criteria. The calcium carbonate equivalent within 40 inches, typically, does not exceed 30 percent. There are no saline horizons within 30 inches of the soil surface.

Map Unit WbB (2.76%)

Map Unit Name:	Floresville fine sandy loam, 1 to 3 percent slopes
Bedrock Depth - Min:	null
Watertable Depth - Annual Min:	null
Drainage Class - Dominant:	Well drained
Hydrologic Group - Dominant:	C - Soils in this group have moderately high runoff potential when thoroughly wet. Water transmission through the soil is somewhat restricted.

Major components are printed below

Floresville(95%)	
horizon A(0cm to 25cm)	Fine sandy loam
horizon Bt(25cm to 76cm)	Clay
horizon Bk(76cm to 112cm)	Sandy clay loam
horizon Bck(112cm to 203cm)	Sandy clay loam

Component Description:

Minor map unit components are excluded from this report.

Map Unit: WbB - Floresville fine sandy loam, 1 to 3 percent slopes

Component: Floresville (95%)

The Floresville component makes up 95 percent of the map unit. Slopes are 1 to 3 percent. This component is on broad ridges on inland, dissected coastal plains. The parent material consists of loamy residuum weathered from sandstone. Depth to a root restrictive layer is greater than 60 inches. The natural drainage class is well drained. Water movement in the most restrictive layer is moderately low. Available water to a depth of 60 inches (or restricted depth) is moderate. Shrink-swell potential is moderate. This soil is not flooded. It is not ponded. There is no zone of water saturation within a depth of 72 inches. Organic matter content in the surface horizon is about 1 percent. This component is in the R083AY024TX Tight Sandy Loam ecological site. Nonirrigated land capability classification is 2e. Irrigated land capability classification is 2e. This soil does not meet hydric criteria. The calcium carbonate equivalent within 40 inches, typically, does not exceed 5 percent. There are no saline horizons within 30 inches of the soil surface.

Component: Miguel (3%)

Generated brief soil descriptions are created for major soil components. The Miguel soil is a minor component.

Component: Wilco (2%)

Generated brief soil descriptions are created for major soil components. The Wilco soil is a minor component.

Map Unit WbC (1.51%)

Map Unit Name:	Floresville fine sandy loam, 3 to 5 percent slopes
Bedrock Depth - Min:	null
Watertable Depth - Annual Min:	null
Drainage Class - Dominant:	Well drained

Soil Information

Hydrologic Group - Dominant: C - Soils in this group have moderately high runoff potential when thoroughly wet. Water transmission through the soil is somewhat restricted.

Major components are printed below

Floresville(95%)	
horizon A(0cm to 25cm)	Fine sandy loam
horizon Bt(25cm to 76cm)	Clay
horizon Bk(76cm to 112cm)	Sandy clay loam
horizon BCk(112cm to 203cm)	Sandy clay loam

Component Description:

Minor map unit components are excluded from this report.

Map Unit: WbC - Floresville fine sandy loam, 3 to 5 percent slopes

Component: Floresville (95%)

The Floresville component makes up 95 percent of the map unit. Slopes are 3 to 5 percent. This component is on broad ridges on inland, dissected coastal plains. The parent material consists of loamy residuum weathered from sandstone. Depth to a root restrictive layer is greater than 60 inches. The natural drainage class is well drained. Water movement in the most restrictive layer is moderately low. Available water to a depth of 60 inches (or restricted depth) is moderate. Shrink-swell potential is moderate. This soil is not flooded. It is not ponded. There is no zone of water saturation within a depth of 72 inches. Organic matter content in the surface horizon is about 1 percent. This component is in the R083AY024TX Tight Sandy Loam ecological site. Nonirrigated land capability classification is 3e. Irrigated land capability classification is 3e. This soil does not meet hydric criteria. The calcium carbonate equivalent within 40 inches, typically, does not exceed 5 percent. There are no saline horizons within 30 inches of the soil surface.

Component: Miguel (3%)

Generated brief soil descriptions are created for major soil components. The Miguel soil is a minor component.

Component: San Antonio (2%)

Generated brief soil descriptions are created for major soil components. The San Antonio soil is a minor component.

Map Unit WeC2 (10.89%)

Map Unit Name:	Floresville fine sandy loam, 1 to 5 percent slopes, eroded
Bedrock Depth - Min:	null
Watertable Depth - Annual Min:	null
Drainage Class - Dominant:	Well drained
Hydrologic Group - Dominant:	C - Soils in this group have moderately high runoff potential when thoroughly wet. Water transmission through the soil is somewhat restricted.

Major components are printed below

Floresville(95%)	
horizon A(0cm to 15cm)	Fine sandy loam
horizon Bt(15cm to 76cm)	Clay
horizon Bk(76cm to 112cm)	Sandy clay loam
horizon BCk(112cm to 203cm)	Sandy clay loam

Component Description:

Minor map unit components are excluded from this report.

Map Unit: WeC2 - Floresville fine sandy loam, 1 to 5 percent slopes, eroded

Component: Floresville (95%)

The Floresville, eroded component makes up 95 percent of the map unit. Slopes are 1 to 5 percent. This component is on broad ridges on inland, dissected coastal plains. The parent material consists of loamy residuum weathered from sandstone. Depth to a root restrictive layer is greater than 60 inches. The natural drainage class is well drained. Water movement in the most restrictive layer is moderately low. Available water to a depth of 60 inches (or restricted depth) is moderate. Shrink-swell potential is moderate. This soil is not flooded. It is not ponded. There is no zone of water saturation within a depth of 72 inches. Organic matter content in the surface horizon is about 1 percent. This component is in the R083AY024TX Tight Sandy Loam ecological site. Nonirrigated land capability classification is 4e. Irrigated land capability classification is 4e. This soil does not meet hydric criteria. The calcium carbonate

Soil Information

equivalent within 40 inches, typically, does not exceed 5 percent. There are no saline horizons within 30 inches of the soil surface.

Component: Miguel (3%)

Generated brief soil descriptions are created for major soil components. The Miguel soil is a minor component.

Component: Wilco (2%)

Generated brief soil descriptions are created for major soil components. The Wilco soil is a minor component.

Pipeline and Survey Information

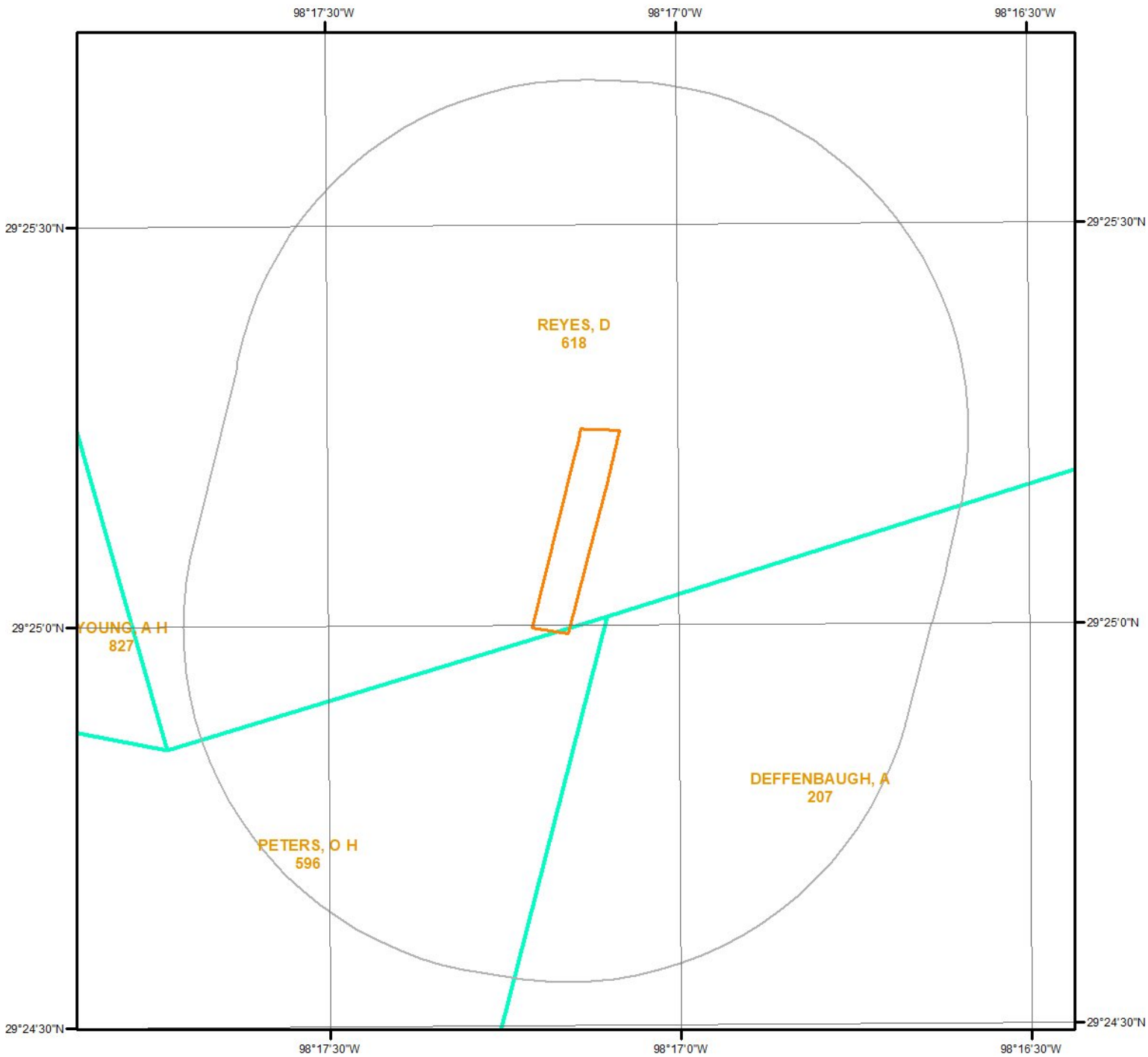

Survey & Pipeline Map

This maps shows Survey & Pipeline around the target property. Please refer to the report for detailed descriptions.

Legend

- Pipeline
- Survey



Pipeline and Survey Detail Report

The previous page shows a pipeline and survey map. Detailed information about each unit is provided below.

No pipeline records found for the project property or surrounding properties.

Wells and Additional Sources

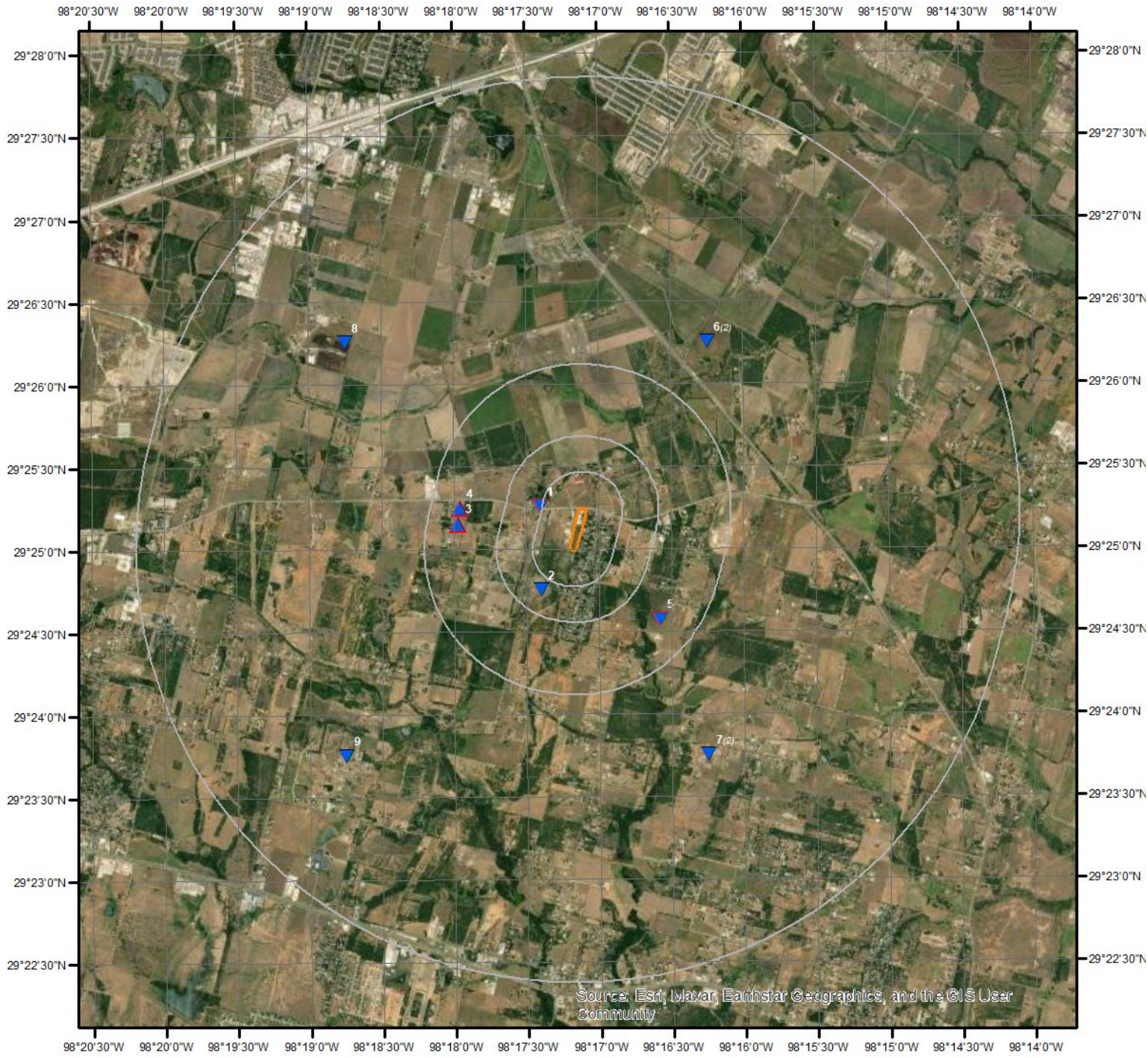

Source: Esri, Maxar, Earthstar Geographics, and the GIS User Community

Wells & Additional Sources

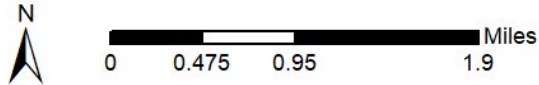

- | | |
|--------------------------------|------------------------------------|
| ▲ Sites with Higher Elevation | ▲ OGW Sites with Higher Elevation |
| ■ Sites with Same Elevation | ■ OGW Sites with Same Elevation |
| ▼ Sites with Lower Elevation | ▼ OGW Sites with Lower Elevation |
| ○ Sites with Unknown Elevation | ● OGW Sites with Unknown Elevation |



Wells and Additional Sources Summary

Federal Sources

Public Water Systems Violations and Enforcement Data

Map Key	ID	Distance (ft)	Direction
---------	----	---------------	-----------

No records found

Safe Drinking Water Information System (SDWIS)

Map Key	ID	Distance (ft)	Direction
---------	----	---------------	-----------

No records found

USGS National Water Information System

Map Key	ID	Distance (ft)	Direction
---------	----	---------------	-----------

No records found

Wells from NWIS

Map Key	ID	Distance (ft)	Direction
---------	----	---------------	-----------

No records found

State Sources

Fort Bend Subsidence District Water Wells

Map Key	ID	Distance (ft)	Direction
---------	----	---------------	-----------

No records found

Groundwater Database

Map Key	ID	Distance (ft)	Direction
---------	----	---------------	-----------

No records found

Harris Galveston Subsidence District Water Wells

Map Key	ID	Distance (ft)	Direction
---------	----	---------------	-----------

No records found

High Plains Water Wells

Map Key	ID	Distance (ft)	Direction
---------	----	---------------	-----------

No records found

Wells and Additional Sources Summary

Oil and Gas Wells

Map Key	API	Distance (ft)	Direction
1	029	1374.19	WNW
3	029	4151.91	W
4	029	4231.04	W
5	029	3983.96	SE

Plotted Water Wells

Map Key	WWD ID	Distance (ft)	Direction
6	727276	7536.94	NE
6	483077	7536.94	NE
7	1033618	8929.50	SSE
7	483083	8929.50	SSE
8	483075	10488.32	NW
9	483081	11126.98	SW

Plugged Water Wells

Map Key	ID	Distance (ft)	Direction
No records found			

Public Water Systems Wells and Surface Intakes

Map Key	ID	Distance (ft)	Direction
No records found			

Select Wells from SDR

Map Key	ID	Distance (ft)	Direction
No records found			

Submitted Drillers Report Database

Map Key	Well Rpt Track No	Distance (ft)	Direction
2	443081	1803.37	SSW
2	Maria Villasenor	1803.37	SSW

Underground Injection Control

Map Key	ID	Distance (ft)	Direction
No records found			

Water Utility Database

Map Key	ID	Distance (ft)	Direction
No records found			

Well Log Reports from Plotted Water Wells

Wells and Additional Sources Summary

Map Key	ID	Distance (ft)	Direction
No records found			

Wells and Additional Sources Detail Report

Oil and Gas Wells

Map Key	Direction	Distance (mi)	Distance (ft)	Elevation (ft)	DB
1	WNW	0.26	1,374.19	636.68	OGW
API:	029	Object ID:			
Uniq ID:	1063544	GIS Lat27:	29.4206969		
GIS API5:		GIS Long27:	-98.2897498		
GIS Well No:	1	GIS Lat83:	29.42093079		
Sym No:	2	GIS Long83:	-98.29003966		
GIS Symbol Desc:	Permitted Location	X:	-98.2900396325637		
Reliab:	15	Y:	29.420930819723267		
GIS Location Source:	Commission`s hardcopy map				

Map Key	Direction	Distance (mi)	Distance (ft)	Elevation (ft)	DB
3	W	0.79	4,151.91	641.75	OGW
API:	029	Object ID:			
Uniq ID:	1063546	GIS Lat27:	29.4189911		
GIS API5:		GIS Long27:	-98.2992468		
GIS Well No:	1	GIS Lat83:	29.41922502		
Sym No:	3	GIS Long83:	-98.29953689		
GIS Symbol Desc:	Dry Hole	X:	-98.29953681526503		
Reliab:	15	Y:	29.419225073977064		
GIS Location Source:	Commission`s hardcopy map				

Map Key	Direction	Distance (mi)	Distance (ft)	Elevation (ft)	DB
4	W	0.80	4,231.04	648.07	OGW
API:	029	Object ID:			
Uniq ID:	1063545	GIS Lat27:	29.4205321		
GIS API5:		GIS Long27:	-98.2990586		
GIS Well No:	1	GIS Lat83:	29.42076596		
Sym No:	2	GIS Long83:	-98.29934869		
GIS Symbol Desc:	Permitted Location	X:	-98.29934867897771		
Reliab:	15	Y:	29.420766032390834		
GIS Location Source:	Commission`s hardcopy map				

Map Key	Direction	Distance (mi)	Distance (ft)	Elevation (ft)	DB
5	SE	0.75	3,983.96	614.63	OGW
API:	029	Object ID:			
Uniq ID:	1063547	GIS Lat27:	29.4092646		

Wells and Additional Sources Detail Report

GIS API5:	GIS Long27:	-98.2760722
GIS Well No: 1	GIS Lat83:	29.40949896
Sym No: 3	GIS Long83:	-98.27636169
GIS Symbol Desc: Dry Hole	X:	-98.2763616329296
Reliab: 15	Y:	29.40949902812992
GIS Location Source: Commission's hardcopy map		

Plotted Water Wells

Map Key	Direction	Distance (mi)	Distance (ft)	Elevation (ft)	DB
6	NE	1.43	7,536.94	571.97	WATER WELLS

WWD ID: 727276	Deg: 68
Grid No: 68-38-6	Sev Min: 38
TX Grid ID: 61026.0	Two Min: 6
TX Grid: 61401.0	Shape Length: 0.0
Perimeter: 17293.361	Shape Area: 0.00173607434508
County: BRAZORIA	
Data Source : Water Well Report Viewer, 2.5 Minute Quad Grid (Map); TCEQ Water Well Public AGO	

Map Key	Direction	Distance (mi)	Distance (ft)	Elevation (ft)	DB
6	NE	1.43	7,536.94	571.97	WATER WELLS

WWD ID: 483077	Deg: 68
Grid No: 68-38-6	Sev Min: 38
TX Grid ID: 61026.0	Two Min: 6
TX Grid: 61401.0	Shape Length: 0.0
Perimeter: 17293.361	Shape Area: 0.00173607434508
County: BEXAR	
Data Source : Water Well Report Viewer, 2.5 Minute Quad Grid (Map); TCEQ Water Well Public AGO	

Map Key	Direction	Distance (mi)	Distance (ft)	Elevation (ft)	DB
7	SSE	1.69	8,929.50	603.56	WATER WELLS

WWD ID: 1033618	Deg: 68
Grid No: 68-38-9	Sev Min: 38
TX Grid ID: 61362.0	Two Min: 9
TX Grid: 61737.0	Shape Length: 0.0
Perimeter: 17296.361	Shape Area: 0.00173595172442
County: WILSON	
Data Source : Water Well Report Viewer, 2.5 Minute Quad Grid (Map); TCEQ Water Well Public AGO	

Map Key	Direction	Distance (mi)	Distance (ft)	Elevation (ft)	DB
7	SSE	1.69	8,929.50	603.56	WATER WELLS

Wells and Additional Sources Detail Report

WWD ID:	483083	Deg:	68
Grid No:	68-38-9	Sev Min:	38
TX Grid ID:	61362.0	Two Min:	9
TX Grid:	61737.0	Shape Length:	0.0
Perimeter:	17296.361	Shape Area:	0.00173595172442
County:	BEXAR		
Data Source :	Water Well Report Viewer, 2.5 Minute Quad Grid (Map); TCEQ Water Well Public AGO		

Map Key	Direction	Distance (mi)	Distance (ft)	Elevation (ft)	DB
8	NW	1.99	10,488.32	622.04	WATER WELLS

WWD ID:	483075	Deg:	68
Grid No:	68-38-5	Sev Min:	38
TX Grid ID:	61025.0	Two Min:	5
TX Grid:	61407.0	Shape Length:	0.0
Perimeter:	17294.699	Shape Area:	0.00173636172761
County:	BEXAR		
Data Source :	Water Well Report Viewer, 2.5 Minute Quad Grid (Map); TCEQ Water Well Public AGO		

Map Key	Direction	Distance (mi)	Distance (ft)	Elevation (ft)	DB
9	SW	2.11	11,126.98	612.94	WATER WELLS

WWD ID:	483081	Deg:	68
Grid No:	68-38-8	Sev Min:	38
TX Grid ID:	61361.0	Two Min:	8
TX Grid:	61745.0	Shape Length:	0.0
Perimeter:	17297.951	Shape Area:	0.00173629311477
County:	BEXAR		
Data Source :	Water Well Report Viewer, 2.5 Minute Quad Grid (Map); TCEQ Water Well Public AGO		

Submitted Drillers Report Database

Map Key	Direction	Distance (mi)	Distance (ft)	Elevation (ft)	DB
2	SSW	0.34	1,803.37	631.34	SDR WELLS

License No:	59591	Well Address1:	1141 Novella
PWS No:		Well Addr2:	
Plug Rpt Track No:		Well City:	Adkins
Well Rpt Track No:	443081	Well Zip:	78101
Orig Well Rpt Trk No:		Owner Well No:	MV WW #1
Apprentice Reg No:	N/A	Owner Name:	Maria Villasenor
No of Wells Drill:	1	Owner Addr1:	1141 Novella
Date Submitted:	2017-02-17	Owner Addr2:	
Type of Work:	New Well	Owner City:	Adkins
Typ of Wrk Oth Descr:		Owner State:	TX
Seal Method:	Tremie	Owner Zip:	78101

Wells and Additional Sources Detail Report

Seal Mthd Oth Desc:		Owner Country:	
Plugged w/i 48Hrs:	No	Driller Name:	Michael A Mello
Drilling Start Dt:	2016-12-27	Driller Address1:	PO Box 715
Drilling End Dt:	2016-12-30	Driller Addr2:	
Proposed Use:	Domestic	Driller City:	Devine
Prop Use Oth Descr:		Driller State:	TX
TCEQ Approve Plans:		Driller Zip:	78016
Apprve by Variance:	Visual	Driller Oth Cntry:	
Loc Vfy by Driller:	Yes	Driller Country:	
Sealed by Driller:	No	Dist to Sep Contam:	150+
Sealed by Name:	Acacia Water Well Services	Dist to Septic Tk:	100+
Driller Signed:	Michael Mello	Dist to Prop Line:	50+
Apprentice Signed:	N/A	Dist Verifi Method:	Visual
Surface Compl:	Surface Sleeve Installed	Horizon Datum Type:	NAD27
Surf Comp Oth Desc:		Elevation:	650
Complt by Driller:	No	Latitude:	29.4125
Pump Type:	Submersible	Lat Degree:	29
Pump Type Oth Desc:		Lat Minute:	24
Pump Depth:	140.00	Lat Second:	45
Chemical Analysis:	No	Longitude:	-98.29
Injurious Water:	No	Long Degree:	98
County:	Bexar	Long Minute:	17
Known Loc Error:	No	Long Second:	24
Grid No:	68-38-9		
Company Name:	Unison Drilling Inc		
Well Location Description:			
Comments:	N/A		
Data Source:	Full SDR Database; SDRDB Well Location (Map)		
Drillers Well Report:	https://www3.twdb.texas.gov/apps/waterdatainteractive/GetReports.aspx?Num=443081&Type=SDR-Well		

Radon Information

This section lists any relevant radon information found for the target property.

Federal EPA Radon Zone for *BEXAR* County: **3**

Zone 1: Counties with predicted average indoor radon screening levels greater than 4 pCi/L

Zone 2: Counties with predicted average indoor radon screening levels from 2 to 4 pCi/L

Zone 3: Counties with predicted average indoor radon screening levels less than 2 pCi/L

Federal Area Radon Information for *BEXAR* County

No Measures/Homes:	57
Geometric Mean:	0.8
Arithmetic Mean:	1.1
Median:	0.8
Maximum:	6.7
% >4 pCi/L:	4
% >20 pCi/L:	0
Notes on Data Table:	TABLE 1. Screening indoor radon data from the State/EPA Residential Radon Survey of Texas conducted during 1990-91. Data represent 2-7 day charcoal canister measurements from the lowest level of each home tested.

Federal Sources

FEMA National Flood Hazard Layer

FEMA FLOOD

The National Flood Hazard Layer (NFHL) data incorporates Flood Insurance Rate Map (FIRM) databases published by the Federal Emergency Management Agency (FEMA), and any Letters Of Map Revision (LOMRs) that have been issued against those databases since their publication date. The FIRM Database is the digital, geospatial version of the flood hazard information shown on the published paper FIRMs. The FIRM Database depicts flood risk information and supporting data used to develop the risk data. The FIRM Database is derived from Flood Insurance Studies (FISs), previously published FIRMs, flood hazard analyses performed in support of the FISs and FIRMs, and new mapping data, where available.

Indoor Radon Data

INDOOR RADON

Indoor radon measurements tracked by the Environmental Protection Agency(EPA) and the State Residential Radon Survey.

Public Water Systems Violations and Enforcement Data

PWSV

List of drinking water violations and enforcement actions from the Safe Drinking Water Information System (SDWIS) made available by the Drinking Water Protection Division of the US EPA's Office of Groundwater and Drinking Water. Enforcement sensitive actions are not included in the data released by the EPA. Address information provided in SWDIS may correspond either with the physical location of the water system, or with a contact address.

Radon Zone Level

RADON ZONE

Areas showing the level of Radon Zones (level 1, 2 or 3) by county. This data is maintained by the Environmental Protection Agency (EPA).

Safe Drinking Water Information System (SDWIS)

SDWIS

The Safe Drinking Water Information System (SDWIS) contains information about public water systems as reported to US Environmental Protection Agency (EPA) by the states. Addresses may correspond with the location of the water system, or with a contact address.

Soil Survey Geographic database

SSURGO

The Soil Survey Geographic database (SSURGO) contains information about soil as collected by the National Cooperative Soil Survey at the Natural Resources Conservation Service (NRCS). Soil maps outline areas called map units. The map units are linked to soil properties in a database. Each map unit may contain one to three major components and some minor components.

U.S. Fish & Wildlife Service Wetland Data

US WETLAND

The U.S. Fish & Wildlife Service Wetland layer represents the approximate location and type of wetlands and deepwater habitats in the United States.

USGS Current Topo

US TOPO

US Topo topographic maps are produced by the National Geospatial Program of the U.S. Geological Survey (USGS). The project was launched in late 2009, and the term "US Topo" refers specifically to quadrangle topographic maps published in 2009 and later.

USGS Geology

US GEOLOGY

Seamless maps depicting geological information provided by the United States Geological Survey (USGS).

USGS National Water Information System

FED USGS

The U.S. Geological Survey (USGS)'s National Water Information System (NWIS) is the nation's principal repository of water resources data. This database includes comprehensive information of well-construction details, time-series data for gage height, streamflow, groundwater level, and precipitation and water use data.

Wells from NWIS

FED USGS

The U.S. Geological Survey's National Water Information System (NWIS) is the nation's principal repository of water resources data. The NWIS includes comprehensive information of well-construction details, time-series data for gage height, streamflow, groundwater level, and precipitation and water use data. This NWIS dataset contains select Site Types from the overall NWIS Sites data, limited to the following Group Site Types only: Groundwater Group Site Types: Well, Collector or Ranney type well, Hyporheic-zone well,

Appendix

Interconnected Wells, Multiple wells; Spring Group Site Type: Spring; and Other Group Site Types: Aggregate groundwater use, Cistern.

State Sources

Fort Bend Subsidence District Water Wells

WW FORT BEND

List of water wells in the Fort Bend Subsidence District, boundaries of which are defined as all the territory within Fort Bend County. The Fort Bend Subsidence District was created by the Texas Legislature in 1989 as a conservation and reclamation district to control land subsidence and manage groundwater resources through regulation, conservation, and coordination with suppliers of alternative water sources to assure an adequate quantity and quality of water for the future. The District's purpose is to provide for the regulation of the withdrawal of groundwater within the District to prevent subsidence that contributes to flooding, inundation or overflow of areas within the District, including rising waters resulting from storms or hurricanes.

Groundwater Database

GWDB

The Texas Water Development Board (TWDB) Groundwater Database (GWDB) contains information on selected water wells, springs, oil/gas tests (that were originally intended to be or were converted to water wells), water levels and water quality.

Harris Galveston Subsidence District Water Wells

WW HARRIS GAL

List of water wells in the Harris-Galveston Subsidence District (HGSD). The HGSD was created by the 64th Texas Legislature as an underground water conservation district in 1975 to provide regulation of groundwater withdrawal to control subsidence.

High Plains Water Wells

WW HIGH PLAINS

Inventory of water wells in the High Plains Underground Water Conservation District No. 1 (HPUWCD), which was created in 1951. As a political subdivision of Texas, HPUWCD is charged with protecting, preserving and conserving aquifers within the District's 16-county service area.

Oil and Gas Wells

OGW

Oil and Gas Well Data made available by the Railroad Commission of Texas.

Pipelines

PIPELINE

Locations of interstate and intrastate gas and liquids pipelines, made available by the Railroad Commission of Texas (RRC). Data is derived from RRC T-4 Permit applications ("Application for Permit to Operate a Pipeline in Texas"), which facilitate regulatory functions of the Pipeline Safety Section of the RRC. The digital data used to create the files was taken from the forms system within the RRC, from the General Land Office (GLO) county survey maps, and, United States Geological Survey (USGS) quadrangle maps.

Plotted Water Wells

WATER WELLS

A list of water wells in Texas that are plotted in Texas Commission on Environmental Quality (TCEQ) Water Well Report Viewer. The database provides the best representation of water well driller's reports available to the TCEQ as of the date of records collected. Note: records are plotted using the Texas Land Survey Grid System, identifying the 2.5 minute grid where wells are located but do not contain the offset necessary to pinpoint a specific location. Therefore, plotted locations are accurate to a resolution of 2.5 minute (2-3 miles).

Plugged Water Wells

PLUGGED WELLS

A list of plugged water wells from the Submitted Drillers Report (SDR) Database. This list is maintained by the Texas Water Development Board (TWDB).

Public Water Systems Wells and Surface Intakes

PWSW

Public Water Supply Water Well Sites and Public Water Supply Surface Water Intake Sites in the State of Texas made available by the Texas Commission on Environmental Quality (TCEQ). The locations for these layers were obtained by the Water Supply Division as recorded from various sources, and the data provider indicates that some locational errors have been identified. As resources allow, TCEQ intends to improve the accuracy of these locations to meet the standards set forth in the agency's Positional Data Policy.

Select Wells from SDR

SDRW WELLS

Locations of wells from the Submitted Drillers Report (SDR) Database with select proposed usage:

Appendix

Domestic, Fracking Supply, Industrial, Irrigation, Other, Public Supply, Rig Supply, Stock, Unknown. SDR is populated from the online Texas Well Report Submission and Retrieval System (TWRSSRS), a cooperative Texas Department of Licensing and Regulation (TDLR) and Texas Water Development Board (TWDB) application requiring registered water-well drillers to submit reports. Excludes SDR records with the following proposed usage: Closed-Loop Geothermal, De-watering, Environmental Soil Boring, Extraction, Injection, Monitor, Test Well.

Submitted Drillers Report Database

SDR WELLS

The Submitted Drillers Report (SDR) Database is populated from the online Texas Well Report Submission and Retrieval System (TWRSSRS) which is a cooperative Texas Department of Licensing and Regulation (TDLR) and Texas Water Development Board (TWDB) application that registered water-well drillers use to submit their required reports.

Surveys

SURVEY

Survey boundaries made available by the Railroad Commission of Texas (RRC). A survey is a certified measured description of a piece of land. In Texas, original surveys were performed as part of the patenting process whereby land was transferred from the public domain. These "patent surveys", recorded at the Texas General Land Office (GLO), constitute an official land grid for the State and are the basis for subsequent land surveys. The digital data used to create surveys were taken from the forms system within the RRC, from the General Land Office (GLO) county survey maps, and United States Geological Survey (USGS) quadrangle maps.

Underground Injection Control

UIC

List of underground injection control (UIC) permits in the Texas Commission on Environmental Quality (TCEQ) Central Registry database. Includes Class I, Class III, Class IV, Class 5, and non permitted UICs; does not include injection wells regulated by the Railroad Commission of Texas.

Water Utility Database

WUD

The Water Utility Database is defined as a collection of data from Texas Water Districts, Public Drinking Water Systems and Water and Sewer Utilities who submit information to the TCEQ. This database is an integrated database designed and developed to replace over 160 stand alone legacy systems representing over 5 million records of the former Texas Water Commission and the Texas Department of Health.

Well Log Reports from Plotted Water Wells

TCEQ WELL LOGS

Locations of TCEQ Water Wells as derived from well logs in the Texas Commission on Environmental Quality (TCEQ) Water Well Report Viewer, which includes unnumbered water wells and those plotted to 2.5 minute grid locations (2-3 miles). In this collection of Well Log Reports, locations have been manually verified.

Liability Notice

Reliance on information in Report: The Physical Setting Report (PSR) DOES NOT replace a full Phase I Environmental Site Assessment but is solely intended to be used as a review of environmental databases and physical characteristics for the site or adjacent properties.

License for use of information in Report: No page of this report can be used without this cover page, this notice and the project property identifier. The information in Report(s) may not be modified or re-sold.

Your Liability for misuse: Using this Service and/or its reports in a manner contrary to this Notice or your agreement will be in breach of copyright and contract and ERIS may obtain damages for such mis-use, including damages caused to third parties, and gives ERIS the right to terminate your account, rescind your license to any previous reports and to bar you from future use of the Service.

No warranty of Accuracy or Liability for ERIS: The information contained in this report has been produced by ERIS Information Inc. ("ERIS") using various sources of information, including information provided by Federal and State government departments. The report applies only to the address and up to the date specified on the cover of this report, and any alterations or deviation from this description will require a new report. This report and the data contained herein does not purport to be and does not constitute a guarantee of the accuracy of the information contained herein and does not constitute a legal opinion nor medical advice. Although ERIS has endeavored to present you with information that is accurate, ERIS Information Inc. disclaims, any and all liability for any errors, omissions, or inaccuracies in such information and data, whether attributable to inadvertence, negligence or otherwise, and for any consequences arising therefrom. Liability on the part of ERIS is limited to the monetary value paid for this report.

Trademark and Copyright: You may not use the ERIS trademarks or attribute any work to ERIS other than as outlined above. This Service and Report(s) are protected by copyright owned by ERIS Information Inc. Copyright in data used in the Service or Report(s) (the "Data") is owned by ERIS or its licensors. The Service, Report(s) and Data may not be copied or reproduced in whole or in any substantial part without prior written consent of ERIS.

APPENDIX I/IIC
WETLANDS REPORT

July 2023
0601-012-11-01-01

ENVIRONMENTAL REPORT

Texas Regional Landfill Company, LP

**Transfer Station
San Antonio, Texas**

PREPARED BY



TABLE OF CONTENTS

1	INTRODUCTION	1
1.1	Project Description	1
2	ECOLOGICAL SITE CHARACTERIZATION	2
2.1	EPA Ecoregion Description	2
2.2	Topography	2
2.3	Vegetation	2
2.4	Soils	3
2.5	Geology	3
2.6	Climate	3
3	ENVIRONMENTAL IMPACTS DESKTOP REVIEW	4
3.1	Waters of the United States	4
3.1.1	Legal Background	4
4	RESULTS AND RECOMMENDATIONS	7
4.1	Summary of Results and Recommendations	7
5	REFERENCES	8

ATTACHMENT 1 – FIGURES

ATTACHMENT 2 – SITE PHOTOGRAPHS

1 INTRODUCTION

1.1 Project Description

Texas Regional Landfill Company, LP contracted Weaver Consultants Group, LLC (WCG) to perform a waters of the U.S. assessment of the proposed transfer station in Bexar County, Texas. The proposed project site will be in an area with a previous operation consisting of a building and associated parking lot. The site is located on Farm-to-Market 1346 in southeast San Antonio (**Attachment 1**). Site photos are located in **Attachment 2**.

2 ECOLOGICAL SITE CHARACTERIZATION

2.1 EPA Ecoregion Description

Ecoregions are areas where ecosystems (and the type, quality, and quantity of environmental resources) are generally similar. Based on U.S. Environmental Protection Agency (EPA) Level III and Level IV Ecoregions the proposed project is located within the Northern Blackland Prairie of the Texas Blackland Prairies (EPA, 2013).

The Texas Blackland Prairies, as the name implies, consists of predominantly prairie vegetation that forms a distinct ecological region. This ecoregion is distinguished from adjacent ecoregions by fine-textured, clayey soils. Croplands have taken over the vast majority of this ecoregion with a continuously increasing expansion of urban and industrial uses (EPA, 2013).

The Northern Blackland Prairie ecoregion is characterized by rolling to nearly level plains that are underlain by interbedded chinks, marls, limestones, and shales of Cretaceous age. Soils are mostly fine-textured, dark, calcareous, and productive Vertisols. Historical vegetation was dominated by little bluestem (*Schizachyrium scoparium*), big bluestem (*Andropogon gerardii*), yellow Indiangrass (*Sorghastrum nutans*), and tall dropseed (*Sporobolus asper*). In lowlands and more mesic sites, such as on some of the clayey Vertisol soils in the higher precipitation areas to the northeast, dominant grasses were eastern gamagrass (*Tripsacum dactyloides*) and switchgrass (*Panicum virgatum*). Most of the prairie has been converted to cropland, non-native pasture, and expanding urban uses (Griffith, et al., 2007).

2.2 Topography

The United States Department of the Interior Geologic Survey (USGS) 7.5-Minute Topographic Maps of the site were reviewed to identify drainages or suspect waters of the United States (WOTUS) within the Site. No streams or other drainages were observed within the project site.

2.3 Vegetation

The natural vegetation of the Northern Blackland Prairie was predominantly prairie with woodlands mainly along riparian corridors, mesic slope forests, and the Austin Chalk escarpment. Grassland areas were dominated by the species mentioned in

Section 2.1 as well as side-oats grama (*Bouteloua curtipendula*), Texas winter grass (*Nasella leucotricha*), prairie bluets (*Hedyotis nigricans*), black-eyed susan (*Rudbeckia hirta*), and old-plainsman (*Hymenopappus scabiosaeus*). Wooded areas, primarily located in riparian areas, included bur oak (*Quercus macrocarpa*), Shumard oak (*Q. shumardii*), sugar hackberry (*Celtis laevigata*), elms (*Ulmus* spp.), ashes (*Fraxinus* spp.), eastern cottonwood (*Populus deltoides*), and pecans (*Carya illinoensis*). Virtually all of the original tallgrass prairies are gone as a result of cultivation and urbanization (*Griffith, G. et al, 2007*).

2.4 Soils

The only soil type within the proposed project area included the San Antonio clay loam, 1 to 3 percent slopes. The San Antonio clay loam consists of well drained soils that formed in stream terraces weathered from loamy alluvium of quaternary age derived from mixed sources. The runoff class is high and there is no frequency of ponding or flooding. These soils are considered prime farmland. These soil are not considered hydric. Their ecological site classification is Eastern Clay Loam.

2.5 Geology

The proposed site's geology is the Wilcox Group, undivided. It is mostly mudstone, with various amounts of sandstone, lignite, ironstone concretions, and glauconitic. Total thickness is roughly 1,400-1,800 feet (*Bureau of Economic Geology, 1974*).

2.6 Climate

The area has average January minimum temperature of 40°F and maximum of 61°F and July temperature minimum of 72°F and maximum of 94°F, and this ecoregion has between 230 to 270 annual frost free days (*Griffith, G., et al, 2007*). This ecoregion receives 42 inches of rainfall on an annual basis.

3 ENVIRONMENTAL IMPACTS DESKTOP REVIEW

3.1 Waters of the United States

3.1.1 Legal Background

The 1972 amendments to the Clean Water Act established federal jurisdiction over “navigable waters,” defined in the Act as the “waters of the United States” (CWA Section 502(7)). Many Clean Water Act programs apply only to “waters of the United States.” (WOTUS). The Clean Water Act provides discretion for U.S. Environmental Protection Agency (EPA) and the U.S. Department of the Army Corps of Engineers (USACE) to define “waters of the United States” in regulations.

The Clean Water Act requires enforceable water quality standards to maintain overall water quality. Standards for bodies of water are based on the water's designated use; such uses include industrial water supplies, swimming, fishing, agricultural irrigation, and more. States establish water quality standards for waterways within their borders, though the EPA may disapprove and replace state standards with its own if they do not meet the act's minimum requirements. The act also requires that standards outline the maximum allowable concentrations of various pollutants that would not inhibit a waterway's designated use

The USACE regulates certain activities occurring in WOTUS per Section 404 of the Clean Water Act (CWA) and Section 10 of the Rivers and Harbors Act of 1899 (RHA). Under Section 404 of the CWA, authorization must be obtained from the USACE for discharges of dredged and fill material into WOTUS. Under Section 10 of the RHA, the USACE regulates work in, or affecting, navigable WOTUS.

Federal agencies that regulate impacts to the nation's water resources located within Texas include the USACE, EPA, and U.S. Fish and Wildlife Service (USFWS). Jurisdictional waters, or WOTUS, are protected under guidelines outlined in Executive Order 11990 (Protection of Wetlands) in Sections 401 and 404 of the CWA and by the state's water quality review process. The USACE has primary regulatory authority for enforcing Section 404 requirements for WOTUS, including wetlands.

Like other federal environmental statutes, the Clean Water Act includes provisions to address civil and criminal violations. Enforcement is shared by the EPA and states, though states generally have primary responsibility given their role in enforcing the discharge permit program and water quality standards. Additionally, the EPA has oversight authority over states and can intervene to bring direct action against

private individuals, businesses, and organizations for violations if the agency believes a state has failed to take the necessary and appropriate action or if a state requests EPA involvement. Civil enforcement involves EPA or state-initiated legal action to compel compliance with federal law and may involve fines or penalties leveled against private parties. Criminal enforcement, which is the sole purview of the federal government, involves criminal investigation and prosecution of deliberate and/or severe violations of federal environmental law.

Under Section 10 of the RHA, the USACE regulates navigable WOTUS. Navigable waters are defined at 33 CFR 329 as those waters that are subject to the ebb and flow of the tide and/or are presently used, have been used in the past, or may be susceptible for use to transport interstate or foreign commerce. A determination of navigability, once made, applies laterally over the entire surface of the waterbody and is not extinguished by later actions or events that impede or destroy navigability. Navigable WOTUS include many coastal waters, including bays and portions of major rivers.

The limit of USACE jurisdiction for non-tidal WOTUS in the absence of adjacent wetlands is the ordinary high-water mark (OHWM). The OHWM is defined as that line on the shore established by the fluctuations of water and indicated by physical characteristics such as the following:

- Clear, natural line impressed on the bank,
- Shelving,
- Changes in the character of the soil,
- Destruction of terrestrial vegetation,
- Presence of litter and debris, or
- Other appropriate means that consider the characteristics of the surrounding areas.

Jurisdictional wetlands are a category of WOTUS and are defined as those areas that are inundated or saturated by surface or groundwater at a frequency and duration sufficient to support, and that under normal circumstances do support, a prevalence of vegetation typically adapted for life in saturated soil conditions. Delineations of wetlands must be conducted using the “Corps of Engineers Wetland Delineation Manual” USACE Waterways Experiment Station Wetlands Research Program Technical Report Y-87-1, dated January 1987, including the supplemental guidance. Bexar County, Texas is located within the region covered by the Regional Supplement to the Corps of Engineers Wetland Delineation Manual: Great Plains Region (Version 2.0), dated March 2010 (USACE 2010).

In January 2001, the U.S. Supreme Court decided the Solid Waste Agency of Northern Cook County (SWANCC) v. U.S. case. This case centered on how isolated wetlands would be regulated. In its decision, the court ruled that the USACE does not have

jurisdiction over intrastate isolated waters that have no nexus to interstate commerce other than use by migratory birds. In the Western U.S., the ruling mostly affected regulation/protection of playa lakes, abandoned mining and borrow pits, hillside seeps, and other potentially isolated waters.

On June 19, 2006, the U.S. Supreme Court decided the *Rapanos et ux., et al v. U.S.* case. Following this decision, the USACE and EPA issued joint guidance on delineation of WOTUS based on the Supreme Court decision. Under this guidance, potential WOTUS have been classified as traditional navigable waters (TNW), relatively permanent waters (RPW) (having flow most of the year at least seasonally), or non-RPWs. Based on the guidance, TNWs and their adjacent wetlands and RPWs and their adjacent wetlands are WOTUS. Wetlands that are bordering, contiguous, or neighboring another WOTUS are considered adjacent. Additionally, wetlands that are within the 100-year floodplain of another WOTUS are considered adjacent. Non-RPWs, wetlands contiguous or adjacent to non-RPWs, and wetlands adjacent to but that do not directly abut an RPW must demonstrate significant nexus on a case-by-case basis to determine the jurisdictional nature of these water features. The significant nexus test requires that a waterbody must have a substantial connection to a TNW by direct flow or have a biological, chemical, and/or hydrological influence on a TNW. This guidance did not void the SWANCC decision. Currently, the EPA and USACE are administering the 404 permit program under the *Rapanos* definition for WOTUS. The U.S. Supreme Court recently heard a case (*Sackett*, October 2022) and issued a decision on May 25, 2023. The Supreme Court decision focused on relatively permanent waters and surface connections. Guidance from the regulatory agencies has not been issued but the appendices' intention is to issue a final rule by September 1, 2023.

Observations

A field investigation was conducted of the proposed project site on May 19, 2023. The project site was occupied by a previous business operation with associated parking, and grassland. The dominant vegetation consists of herbaceous species including plains coreopsis (*Coreopsis tinctoria*), Santa Maria feverfew (*Parthenium hysterophorus*), Texas vervain (*Verbena halei*), annual ragweed (*Ambrosia artemisifolia*), wild petunia (*Ruellia nudiflora*), rescuegrass (*Bromus catharticus*), threelobe false mallow (*Malvastrum coromandelianum*), white tridens (*Tridens albescens*), evening primrose (*Oenothera speciosa*), Carolina canarygrass (*Phalaris caroliniana*), perennial ryegrass (*Lolium perenne*), Johnsongrass (*Sorghum halepense*), KR bluestem (*Bothriochloa ischaemum*), fiddle dock (*Rumex pulcher*), Texas wintergrass (*Nassella leucotricha*), peppergrass (*Lepidium* spp.), prairie coneflower (*Ratibida columnifera*), Venus looking glass (*Triodanis perfoliata*), Texas thistle (*Cirsium texanum*), frogfruit (*Phyla nodiflora*), bermudagrass (*Cynodon dactylon*), lemon beebalm (*Monarda citriodora*), grass-leaved rush (*Juncus marginatus*), and mesquite (*Prosopis glandulosa*).

4 RESULTS AND RECOMMENDATIONS

4.1 Summary of Results and Recommendations

The proposed project site is dominated by a previous business operation and grassland. Based on field observations and research, there were no waters of the U.S. on the project site.

5 REFERENCES

Bureau of Economic Geology, 1974, Austin Sheet, Geologic Atlas of Texas, University of Texas, Bureau of Economic Geology, scale 1:250,000.

Environmental Protection Agency (EPA), 2013, Level III and IV ecoregions of the continental United States: Corvallis, Oregon, U.S. EPA, National Health and Environmental Effects Research Laboratory, map scale 1:3,000,000, <https://www.epa.gov/eco-research/level-iii-and-iv-ecoregions-continental-united-states>.

Griffith, G., Griffith, S., Omernick, J., and Rogers, A., 2007, Ecoregions of Texas: Texas Commission on Environmental Quality.

ATTACHMENT 1
FIGURES

0:\0601\12\TYPE V APPLICATION\PARTS F-I\FIG 4.2-TOPO MAP.dwg, mbahmani, 1:2

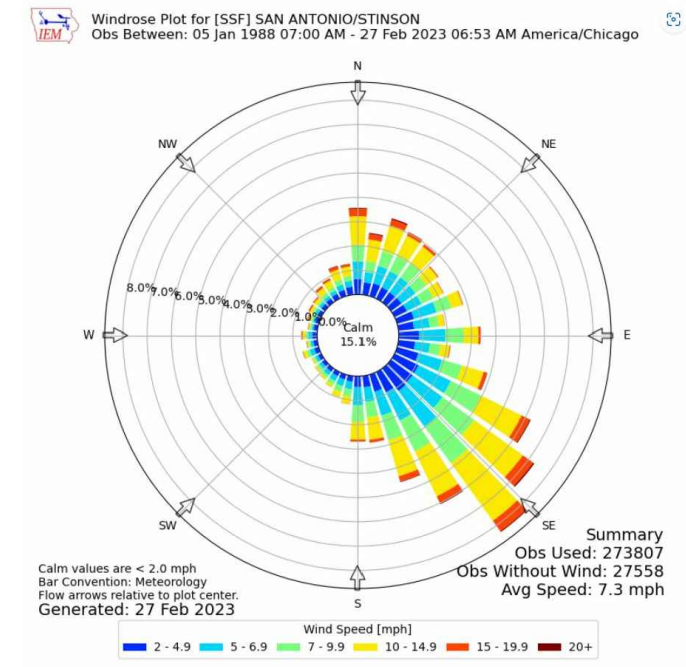
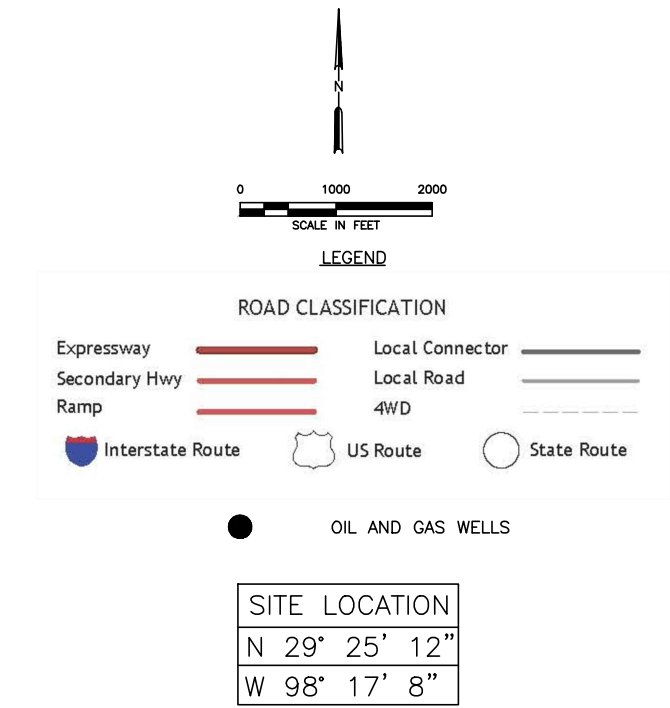
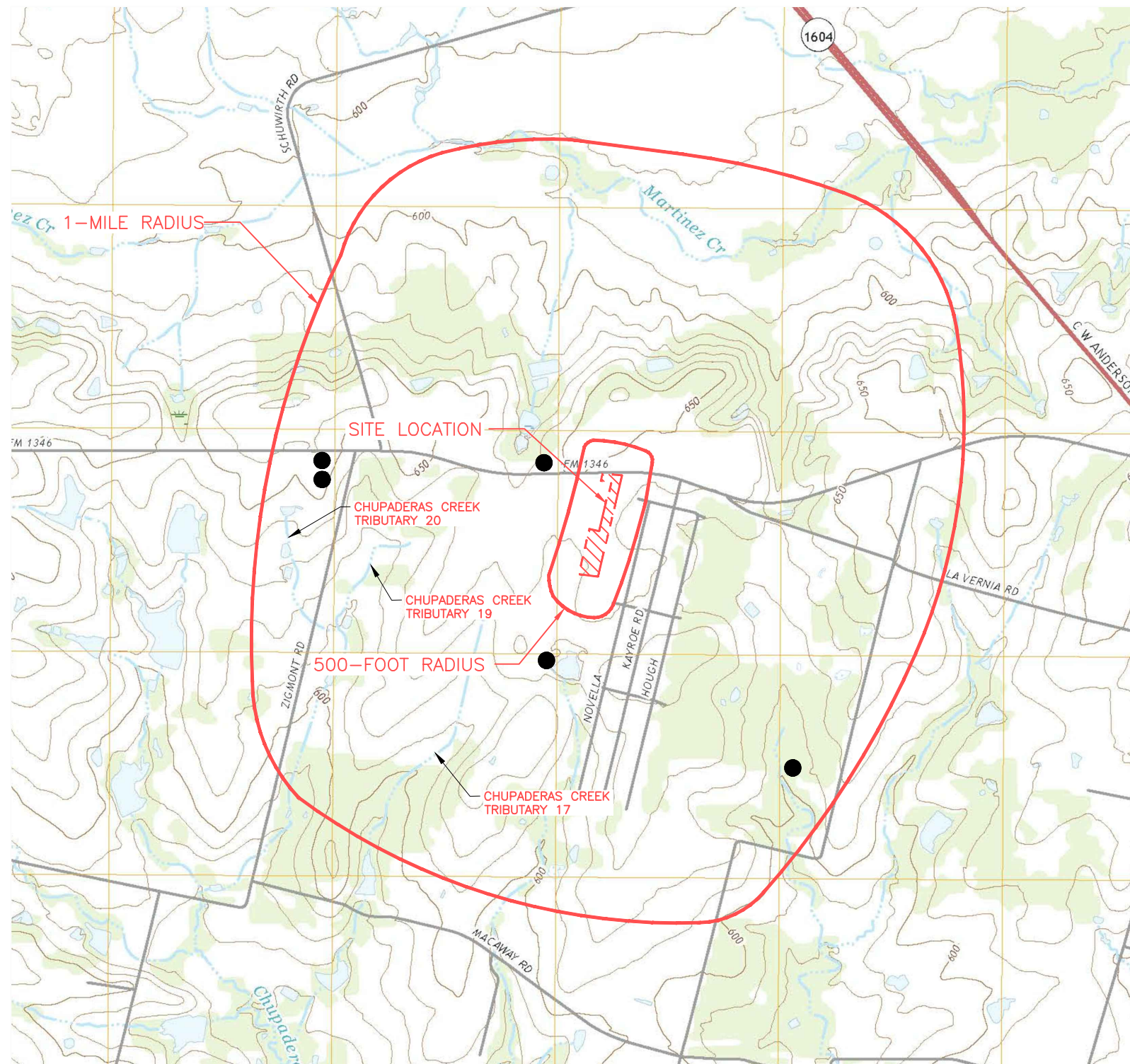

- NOTE:**
- ADAPTED FROM THE USGS 7.5 MINUTE QUADRANGLE TOPOGRAPHIC MAPS (MARTINEZ, TX 2022)
 - THERE ARE NO SPRINGS WITHIN 1 MILE OF THE SITE LOCATION.
 - OIL AND GAS LOCATIONS ARE PROVIDED BY ERIS DATABASE DATED FEBRUARY 7, 2023.

Tech. Complete App. - 216

<input type="checkbox"/> DRAFT <input checked="" type="checkbox"/> FOR PERMITTING PURPOSES ONLY <input type="checkbox"/> ISSUED FOR CONSTRUCTION	PREPARED FOR TEXAS REGIONAL LANDFILL COMPANY, LP	TYPE V REGISTRATION APPLICATION GENERAL TOPOGRAPHIC MAP SAN ANTONIO TRANSFER STATION BEXAR COUNTY, TEXAS
	DATE: 09/2023 FILE: 0601-012-11 CAD: FIG 4.2-GENERAL TOPO MAP.DWG	
Weaver Consultants Group TBPE REGISTRATION NO. F-3727		WWW.WCGRP.COM FIGURE 1/II-4.2

0:\0601\12\TYPE V APPLICATION\PARTS 1-I\FIG 4.3-AERIAL PHOTOGRAPH.dwg, mbahmani, 1:2

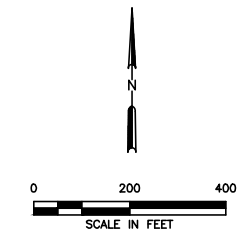

LEGEND

- - - REGISTRATION BOUNDARY
- IB INHABITABLE STRUCTURES
- IC INDUSTRIAL/COMMERCIAL STRUCTURES
- R RESIDENCE
- CH CHURCH

NOTES:

1. AERIAL PHOTOGRAPH PROVIDED BY GOOGLE EARTH DATED AUGUST 9, 2022.
2. ALL STRUCTURES WITHIN 500 FEET OF THE PERMIT BOUNDARY ARE SHOWN ON THIS FIGURE.
3. THE NEAREST RESIDENCE IS LOCATED APPROXIMATELY 48 FEET EAST OF THE REGISTRATION BOUNDARY.

Tech. Complete App. - 217

<input type="checkbox"/> DRAFT <input checked="" type="checkbox"/> FOR PERMITTING PURPOSES ONLY <input type="checkbox"/> ISSUED FOR CONSTRUCTION	PREPARED FOR TEXAS REGIONAL LANDFILL COMPANY, LP	TYPE V REGISTRATION APPLICATION AERIAL PHOTOGRAPH													
DATE: 09/2023 FILE: 0601-012-11 CAD: FIG 6.1-AERIAL PHOTOGRAPH.DWG	DRAWN BY: SRF DESIGN BY: MB REVIEWED BY: CRM	SAN ANTONIO TRANSFER STATION BEXAR COUNTY, TEXAS													
Weaver Consultants Group TBPE REGISTRATION NO. F-3727		REVISIONS <table border="1" style="width: 100%; border-collapse: collapse;"> <thead> <tr> <th style="width: 5%;">NO.</th> <th style="width: 10%;">DATE</th> <th style="width: 85%;">DESCRIPTION</th> </tr> </thead> <tbody> <tr><td> </td><td> </td><td> </td></tr> <tr><td> </td><td> </td><td> </td></tr> <tr><td> </td><td> </td><td> </td></tr> </tbody> </table>	NO.	DATE	DESCRIPTION										WWW.WCGRP.COM
NO.	DATE	DESCRIPTION													
I/IIC-16		FIGURE 1/II-4.3													

O:\0601\12\TYPE V APPLICATION\PARTS 1-II\FIG 4.4-PROPOSED SITE PLAN.dwg, mbahmani, 1:2

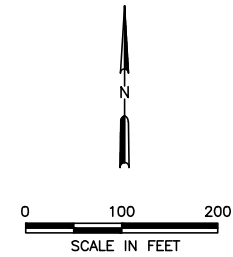

LEGEND

	REGISTRATION BOUNDARY
	EXISTING CONTOUR
	PROPOSED BUILDING
	EXISTING GRAVEL PAVEMENT
	PROPOSED GRAVEL PAVEMENT
	50-FOOT BUFFER ZONE
	ACCESS CONTROL FENCE (SEE NOTE 3)
	PROPOSED OPERATIONS AREA FENCE (SEE NOTE 2)
	PROPOSED CONCRETE OR ASPHALT PAVEMENT

NOTES:

1. THE EXISTING CONTOURS PROVIDED BY TEXAS RESOURCE INFORMATION SYSTEM (TNRIS) BEXAR AND TRAVIS COUNTIES LIDAR, 2022.
2. THE TRANSFER STATION ACCESS WILL BE CONTROLLED BY A FENCE AROUND THE PROPERTY WITH GATES ON THE FACILITY ENTRANCE ROAD. AREAS WITH DENSE TREES PROVIDE A NATURAL BARRIER AROUND THE EAST SIDE OF THE FACILITY BOUNDARY.
3. PERIMETER FENCE ACCESS POINTS MAY BE INSTALLED TO FACILITATE SITE MAINTENANCE AND OPERATIONS.

Tech. Complete App. - 218

<input type="checkbox"/> 90% REVIEW <input checked="" type="checkbox"/> FOR PERMITTING PURPOSES ONLY <input type="checkbox"/> ISSUED FOR CONSTRUCTION	PREPARED FOR TEXAS REGIONAL LANDFILL COMPANY, LP		TYPE V REGISTRATION APPLICATION PROPOSED SITE PLAN SAN ANTONIO TRANSFER STATION BEXAR COUNTY, TEXAS			
	DATE: 09/2023 FILE: 0601-012-11 CAD: FIG 4.4-PROPOSED SITE PLAN.DWG	DRAWN BY: RAA DESIGN BY: MB REVIEWED BY: CRM			REVISIONS	
Weaver Consultants Group TBPE REGISTRATION NO. F-3727		NO.	DATE	DESCRIPTION	WWW.WCGRP.COM	FIGURE 1/II-4.4

0:\0601\12\TYPE V APPLICATION\PARTS F-H\FIG 5.1-LAND OWNER MAP.dwg, mbahmann, 1:2

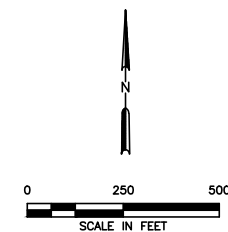

LEGEND

	REGISTRATION BOUNDARY
	PROPERTY BOUNDARY LINES
	PROPERTY OWNER DESIGNATION

NOTES:

1. PROPERTY BOUNDARIES AND OWNER INFORMATION PROVIDED BY BEXAR COUNTY TAX APPRAISAL WEBSITE, AND APPRAISAL DISTRICT RECORDS AS OF JULY 2023.
2. REFERS TO PROPERTY OWNERS LISTED ON PROPERTY OWNERS LIST IN SECTION 5, PROPERTY OWNERS LIST AND MAP.

Tech. Complete App. - 219

<input type="checkbox"/> DRAFT <input checked="" type="checkbox"/> FOR PERMITTING PURPOSES ONLY <input type="checkbox"/> ISSUED FOR CONSTRUCTION	PREPARED FOR TEXAS REGIONAL LANDFILL COMPANY, LP	TYPE V REGISTRATION APPLICATION LAND OWNER'S MAP																
DATE: 09/2023 FILE: 0601-012-11 CAD: FIG 5.1-LAND OWNER'S MAP.DWG	DRAWN BY: RAA DESIGN BY: MB REVIEWED BY: CRM	SAN ANTONIO TRANSFER STATION BEXAR COUNTY, TEXAS																
Weaver Consultants Group TBPE REGISTRATION NO. F-3727		<table border="1" style="width: 100%; border-collapse: collapse;"> <thead> <tr> <th colspan="3" style="text-align: center;">REVISIONS</th> </tr> <tr> <th style="width: 10%;">NO.</th> <th style="width: 10%;">DATE</th> <th>DESCRIPTION</th> </tr> </thead> <tbody> <tr><td> </td><td> </td><td> </td></tr> <tr><td> </td><td> </td><td> </td></tr> <tr><td> </td><td> </td><td> </td></tr> </tbody> </table>	REVISIONS			NO.	DATE	DESCRIPTION										WWW.WCGRP.COM
REVISIONS																		
NO.	DATE	DESCRIPTION																
I/IIC-18		FIGURE I/II-5.1																

0:\0601\12\TYPE V APPLICATION\PARTS 1-II\FIG 6.1-AERIAL PHOTOGRAPH.dwg, mbahmani, 1:2

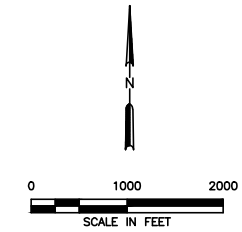
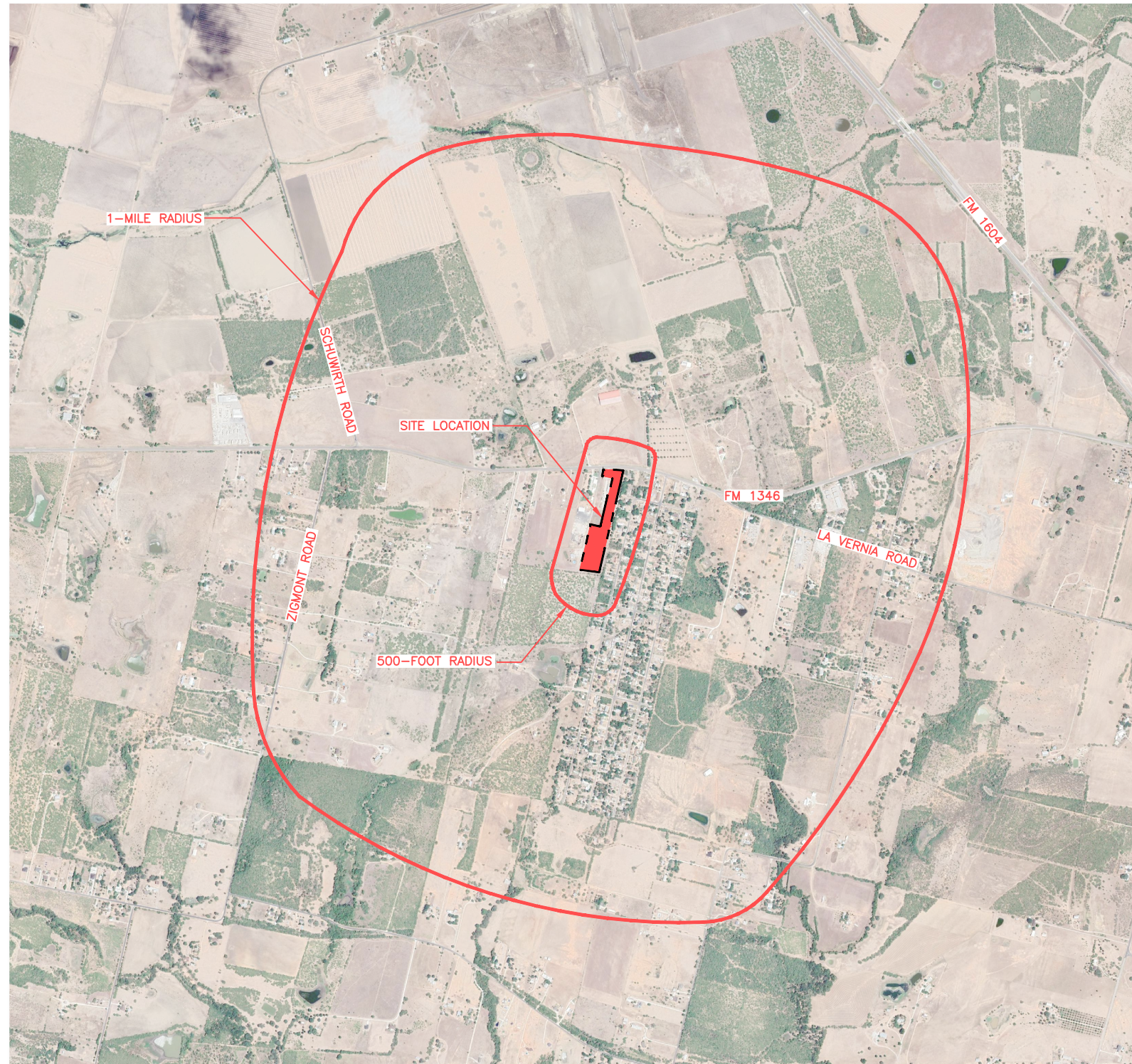

NOTES:

1. AERIAL PHOTOGRAPH PROVIDED BY GOOGLE EARTH DATED AUGUST 09, 2022.

Tech. Complete App. - 220

<input type="checkbox"/> DRAFT <input checked="" type="checkbox"/> FOR PERMITTING PURPOSES ONLY <input type="checkbox"/> ISSUED FOR CONSTRUCTION	PREPARED FOR TEXAS REGIONAL LANDFILL COMPANY, LP		TYPE V REGISTRATION APPLICATION AERIAL PHOTOGRAPH SAN ANTONIO TRANSFER STATION BEXAR COUNTY, TEXAS			
	DATE: 09/2023 FILE: 0601-012-11 CAD: FIG 6.1-AERIAL PHOTOGRAPH.DWG	DRAWN BY: RAA DESIGN BY: MB REVIEWED BY: CRM			REVISIONS	
Weaver Consultants Group TBPE REGISTRATION NO. F-3727		NO.	DATE	DESCRIPTION	WWW.WCGRP.COM	FIGURE I/II-6.1

0:\0601\12\TYPE V APPLICATION\PARTS 1-II\FIG 7.1-1 LAND USE MAP.dwg, mbahmani, 1:2

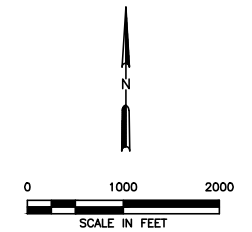

LEGEND

	PERMIT BOUNDARY
	1-MILE RADIUS
R	RESIDENTIAL
IC	INDUSTRIAL/COMMERCIAL
AG	AGRICULTURAL/OPEN SPACE
	EXISTING STREAM

- NOTES:**
1. AERIAL PHOTOGRAPH PROVIDED BY GOOGLE EARTH DATED AUGUST 09, 2022.
 2. LAND USE IS SHOWN ONLY WITHIN THE 1-MILE BOUNDARY.
 3. SITE ACCESS ROADS WITHIN 1 MILE OF THE SITE INCLUDE FM 1346.
 4. EXCEPT AS OTHERWISE SHOWN, LAND USE IS PREDOMINANTLY AGRICULTURAL, INDUSTRIAL/COMMERCIAL, AND RESIDENTIAL.
 5. REFER TO FIGURE I/II-4.3 FOR INFORMATION REGARDING STRUCTURES AND INHABITABLE BUILDINGS WITHIN 500 FEET OF THE PERMIT BOUNDARY.
 6. THERE ARE NO LAKES, AND SEVERAL SMALL PONDS WITHIN THE 1-MILE RADIUS.
 7. ALL PAVED ROADS TO BE USED NORMALLY BY TRLC TO ACCESS THE FACILITY WITHIN THE 1-MILE RADIUS ARE EITHER ASPHALT OR CONCRETE.

Tech. Complete App. - 221

<input type="checkbox"/> DRAFT <input checked="" type="checkbox"/> FOR PERMITTING PURPOSES ONLY <input type="checkbox"/> ISSUED FOR CONSTRUCTION	PREPARED FOR TEXAS REGIONAL LANDFILL COMPANY, LP		TYPE V PERMIT AMENDMENT APPLICATION LAND USE MAP SAN ANTONIO TRANSFER STATION BEXAR COUNTY, TEXAS											
	DATE: 09/2023 FILE: 0601-012-11 CAD: FIG 7.1-LAND USE MAP.DWG	DRAWN BY: RAA DESIGN BY: MB REVIEWED BY: CRM		REVISIONS <table border="1"> <thead> <tr> <th>NO.</th> <th>DATE</th> <th>DESCRIPTION</th> </tr> </thead> <tbody> <tr><td> </td><td> </td><td> </td></tr> <tr><td> </td><td> </td><td> </td></tr> <tr><td> </td><td> </td><td> </td></tr> </tbody> </table>	NO.	DATE	DESCRIPTION							
NO.	DATE	DESCRIPTION												
Weaver Consultants Group TBPE REGISTRATION NO. F-3727		WWW.WCGRP.COM	FIGURE I/II-7.1											

0:\0601\12\TYPE V APPLICATION\PARTS 1-II\FIG 7.2-CITIES WITHIN 5-MILE RADIUS.dwg, mbahmani, 1:2

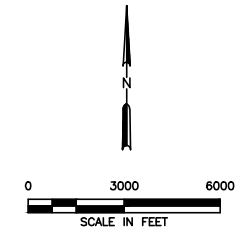
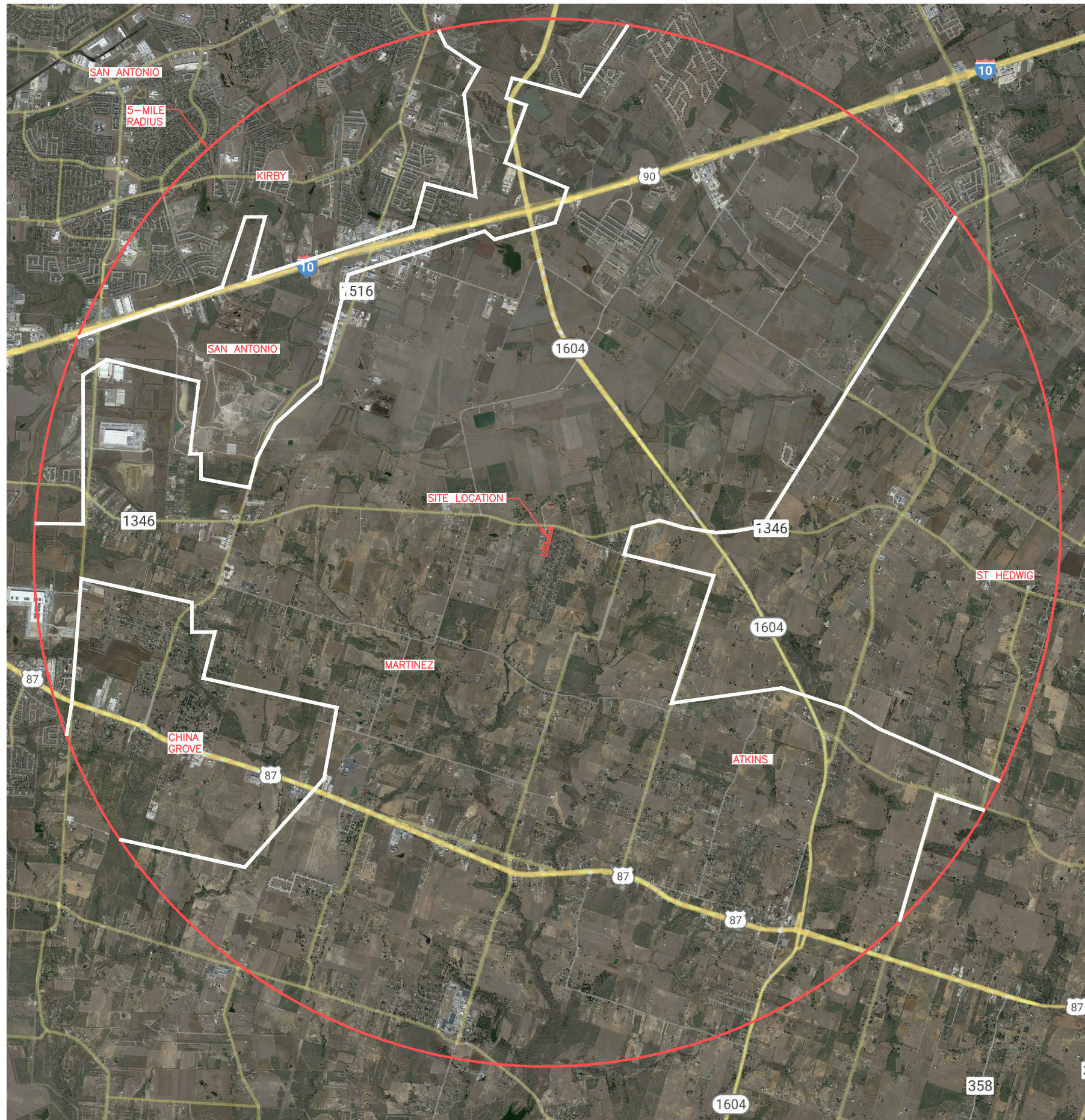

NOTES:

1. AERIAL PHOTOGRAPH PROVIDED BY GOOGLE EARTH DATED DECEMBER 16, 2020.
2. MARTINEZ AND ATKINS ARE UNINCORPORATED COMMUNITIES IN BEXAR COUNTY.

Tech. Complete App. - 222

<input type="checkbox"/> DRAFT <input checked="" type="checkbox"/> FOR PERMITTING PURPOSES ONLY <input type="checkbox"/> ISSUED FOR CONSTRUCTION	PREPARED FOR		TEXAS REGIONAL LANDFILL COMPANY, LP TYPE V REGISTRATION APPLICATION CITIES WITHIN 5-MILE RADIUS SAN ANTONIO TRANSFER STATION BEXAR COUNTY, TEXAS												
	DATE: 09/2023 FILE: 0601-012-11 CAD: FIG 7.2-CITIES WITHIN 5-MILES.DWG			DRAWN BY: RAA DESIGN BY: MB REVIEWED BY: CRM											
Weaver Consultants Group TBPE REGISTRATION NO. F-3727			REVISIONS <table border="1"> <thead> <tr> <th>NO.</th> <th>DATE</th> <th>DESCRIPTION</th> </tr> </thead> <tbody> <tr> <td> </td> <td> </td> <td> </td> </tr> <tr> <td> </td> <td> </td> <td> </td> </tr> <tr> <td> </td> <td> </td> <td> </td> </tr> </tbody> </table>	NO.	DATE	DESCRIPTION									
NO.	DATE	DESCRIPTION													
WWW.WCGRP.COM		FIGURE I/II-7.2													

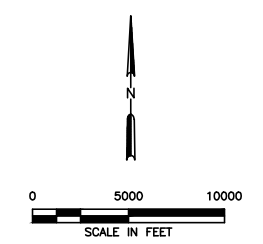
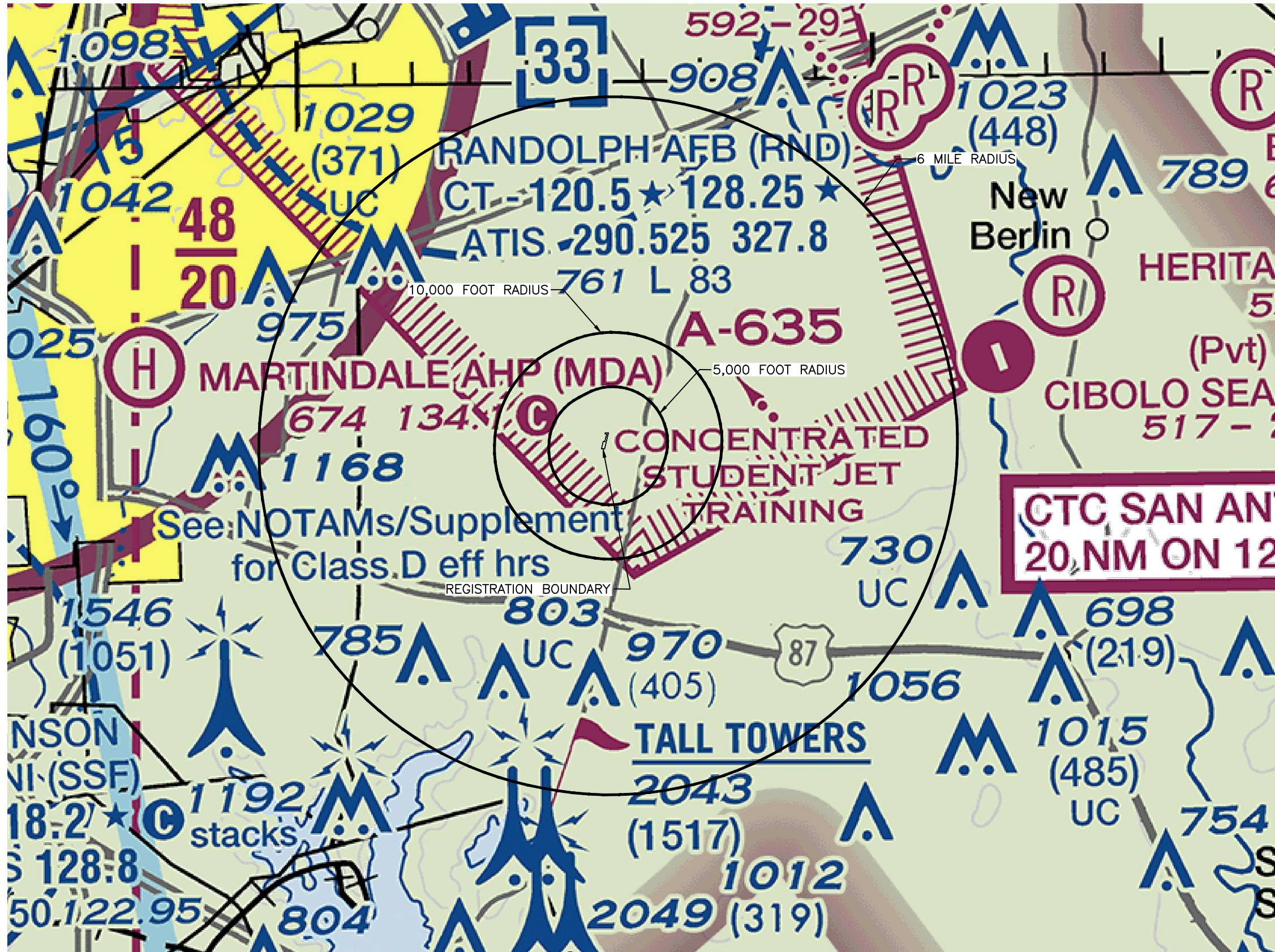

LEGEND

AIRPORTS

- Other than hard-surfaced runways
- Hard-surfaced runways 1500 ft. to 8069 ft. in length
- Hard-surfaced runways greater than 8069 ft. or some multiple runways less than 8069 ft.
- Open dot within hard-surfaced runway configuration indicates approximate VOR, VOR-DME, DME or VORTAC location.
- All recognizable hard-surfaced runways, including those closed, are shown for visual identification. Airports may be public or private.

ADDITIONAL AIRPORT INFORMATION

- Private "(Pvt)" - Non-public use having landmark value
- Military - Other than hard-surfaced; all military airports are identified by abbreviations AFB, NAS, AAF, etc.
- Heliport Selected
- Unverified
- Abandoned - paved having landmark value, 3000 ft. or greater
- Ultraflight Flight Park Selected

Fuel availability indicated by use of tick marks around basic airport symbol. Consult Supplement for details and availability at airports with hard-surfaced runways greater than 8069 ft.

★ Rotating airport beacon in operation Sunset to Sunrise

OBJECTIONABLE - Airport may adversely affect airspace use.

***Alert Area and Military Operations Area (MOA)**
(may be lit or unlit)

OBSTRUCTIONS
(may be lit or unlit)

- 1000 ft and higher AGL
- Above 200 ft & below 1000 ft AGL (above 299 ft AGL in urban area)
- Obstruction with high-intensity lights; may operate part-time
- Wind Turbine Farm
- Wind Turbine Elevation of the top above mean sea level
- Group Obstruction
- Under construction or reported position and elevation unverified
- NOTICE: Guy wires may extend outward from structures.

TOPOGRAPHIC INFORMATION

- Power Transmission Line
- Aerial Cable
- Lookout Tower
- 618 (Elevation Base of Tower)
- Mountain Pass
- 71823 (Elevation of Pass)
- Pass symbol does not indicate a recommended route or direction of flight and pass elevation does not indicate a recommended clearance altitude. Hazardous flight conditions may exist within and near mountain passes.

- NOTES:**
- THIS MAP REPRODUCED FROM THE FAA SAN ANTONIO SECTIONAL AERONAUTICAL CHART EDITION DATED JUNE 15, 2023.
 - THE NEAREST AIRPORTS TO THE REGISTRATION BOUNDARY ARE STINSON-MISSION MUNICIPAL AIRPORT LOCATED 12 MILES SOUTHWEST, AND SAN ANTONIO INTERNATIONAL LOCATED 13 MILES NORTHWEST.

Tech. Complete App. - 223

<input type="checkbox"/> DRAFT <input checked="" type="checkbox"/> FOR INFORMATION PURPOSES ONLY <input type="checkbox"/> ISSUED FOR CONSTRUCTION	PREPARED FOR TEXAS REGIONAL LANDFILL COMPANY, LP	TYPE V REGISTRATION APPLICATION AREA AIRPORTS SAN ANTONIO TRANSFER STATION BEXAR COUNTY, TEXAS
	DATE: 09/2023 FILE: 0601-012-11 CAD: FIG I/II-8.1-AREA AIRPORTS.DWG	
WEAVER CONSULTANTS GROUP TBPE REGISTRATION NO. F-3727		WWW.WCGRP.COM

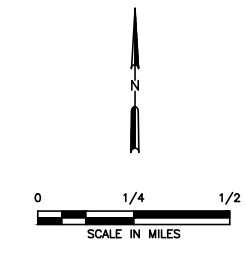

LEGEND

PERMIT BOUNDARY	

SPECIAL FLOOD HAZARD AREAS	Without Base Flood Elevation (BFE) Zone A, AE, AH, AR With BFE or Depth Zone AE, AH, AR, VE, AR
	Regulatory Floodway
OTHER AREAS OF FLOOD HAZARD	0.2% Annual Chance Flood Hazard, Areas of 1% annual chance flood with average depth less than one foot or with drainage areas of less than one square mile Zone X
	Future Conditions 1% Annual Chance Flood Hazard Zone X
	Area with Reduced Flood Risk due to Levee See Notes Zone X
OTHER AREAS	Area with Flood Risk due to Levee Zone D
	NO SCREEN Area of Minimal Flood Hazard Zone X
OTHER AREAS	Effective LOMRs
	Area of Undetermined Flood Hazard Zone D
GENERAL STRUCTURES	Channel, Culvert, or Storm Sewer
	Levee, Dike, or Floodwall
OTHER FEATURES	20.2 Cross Sections with 1% Annual Chance Water Surface Elevation
	17.5 Coastal Transect
	Coastal Transect Baseline
	Profile Baseline
	Hydrographic Feature
OTHER FEATURES	Base Flood Elevation Line (BFE)
	Limit of Study
OTHER FEATURES	Jurisdiction Boundary

NOTES:

- FLOODPLAIN INFORMATION PROVIDED BY FEMA FIRM PANEL 48029C0445G FOR BEXAR COUNTY, TEXAS AND INCORPORATED AREAS DATED SEPTEMBER 29, 2010.

Tech. Complete App. - 224

<input type="checkbox"/> DRAFT <input checked="" type="checkbox"/> FOR PERMITTING PURPOSES ONLY <input type="checkbox"/> ISSUED FOR CONSTRUCTION	PREPARED FOR	TEXAS REGIONAL LANDFILL COMPANY, LP TYPE V REGISTRATION APPLICATION FLOOD INSURANCE RATE MAP SAN ANTONIO TRANSFER STATION BEXAR COUNTY, TEXAS								
	DATE: 09/2023 FILE: 0601-012-11 CAD: FIG 11.1-FIRM.DWG		DESIGN BY: RAA DESIGN BY: MB REVIEWED BY: CRM							
REVISIONS		WWW.WCGRP.COM FIGURE I/II-11.1								
<table border="1"> <thead> <tr> <th>NO.</th> <th>DATE</th> <th>DESCRIPTION</th> </tr> </thead> <tbody> <tr> <td> </td> <td> </td> <td> </td> </tr> <tr> <td> </td> <td> </td> <td> </td> </tr> </tbody> </table>			NO.	DATE	DESCRIPTION					
NO.	DATE	DESCRIPTION								
Weaver Consultants Group TBPE REGISTRATION NO. F-3727										

ATTACHMENT 2
SITE PHOTOGRAPHS



Photo 1 – View of the building on the subject property.



Photo 2 – View looking south along the west boundary.



Photo 3 – View looking east along the southern edge of existing development.



Photo 4 – View of parking area on subject property.



Photo 5 – View of rangeland comprising the southern portion of the subject property.



Photo 6 – View from the south end looking north at subject property.

APPENDIX I/IIID

THREATENED AND ENDANGERED SPECIES REPORT

July 2023
0601-012-11-01-01

BIOLOGICAL REPORT

Texas Regional Landfill Company, LP

**Transfer Station
San Antonio, Texas**

PREPARED BY



TABLE OF CONTENTS

1	INTRODUCTION	1
1.1	Project Description	1
2	ECOLOGICAL SITE CHARACTERIZATION	2
2.1	EPA Ecoregion Description	2
2.2	Vegetation	2
2.3	Soils	3
2.4	Geology	3
2.5	Climate	3
3	ENVIRONMENTAL IMPACTS DESKTOP REVIEW	4
3.1	Potential Impacted Species and Migratory Birds	4
3.1.1	Threatened/Endangered Species	4
3.1.2	Candidate Species	6
3.1.3	Migratory Birds	7
3.2	Observations	8
4	RESULTS AND RECOMMENDATIONS	10
4.1	Summary of Results and Recommendations	10
5	REFERENCES	11

ATTACHMENT 1 – FIGURES

ATTACHMENT 2 – SITE PHOTOS

ATTACHMENT 3 – USFWS IPAC SPECIES LISTS

ATTACHMENT 4 – TPWD RARE SPECIES LIST

1 INTRODUCTION

1.1 Project Description

Texas Regional Landfill Company, LP contracted Weaver Consultants Group, LLC (WCG) to perform a biological assessment of the proposed transfer station in Bexar County, Texas. The proposed project site will be in an area with a previous business operation consisting of a building and associated parking lot. The site is located on Farm-to-Market 1346 in southeast San Antonio (**Attachment 1**). Site photos are located in **Attachment 2**.

The purpose of this biological assessment is to characterize the ecological conditions at the proposed project location and provide a review of the potential presence of threatened and endangered species, migratory birds, and other sensitive species.

2 ECOLOGICAL SITE CHARACTERIZATION

2.1 EPA Ecoregion Description

Ecoregions are areas where ecosystems (and the type, quality, and quantity of environmental resources) are generally similar. Based on U.S. Environmental Protection Agency (EPA) Level III and Level IV Ecoregions the proposed project is located within the Northern Blackland Prairie of the Texas Blackland Prairies (EPA, 2013).

The Texas Blackland Prairies, as the name implies, consists of predominantly prairie vegetation that forms a distinct ecological region. This ecoregion is distinguished from adjacent ecoregions by fine-textured, clayey soils. Croplands have taken over the vast majority of this ecoregion with a continuously increasing expansion of urban and industrial uses (EPA, 2013).

The Northern Blackland Prairie ecoregion is characterized by rolling to nearly level plains that are underlain by interbedded chalks, marls, limestones, and shales of Cretaceous age. Soils are mostly fine-textured, dark, calcareous, and productive Vertisols. Historical vegetation was dominated by little bluestem (*Schizachyrium scoparium*), big bluestem (*Andropogon gerardii*), yellow Indiangrass (*Sorghastrum nutans*), and tall dropseed (*Sporobolus asper*). In lowlands and more mesic sites, such as on some of the clayey Vertisol soils in the higher precipitation areas to the northeast, dominant grasses were eastern gamagrass (*Tripsacum dactyloides*) and switchgrass (*Panicum virgatum*). Most of the prairie has been converted to cropland, non-native pasture, and expanding urban uses (Griffith, et al., 2007).

2.2 Vegetation

The natural vegetation of the Northern Blackland Prairie was predominantly prairie with woodlands mainly along riparian corridors, mesic slope forests, and the Austin Chalk escarpment. Grassland areas were dominated by the species mentioned in Section 2.1 as well as side-oats grama (*Bouteloua curtipendula*), Texas winter grass (*Nasella leucotricha*), prairie bluets (*Hedyotis nigricans*), black-eyed susan (*Rudbeckia hirta*), and old-plainsman (*Hymenopappus scabiosaeus*). Wooded areas, primarily located in riparian areas, included bur oak (*Quercus macrocarpa*), Shumard oak (*Q. shumardii*), sugar hackberry (*Celtis laevigata*), elms (*Ulmus* spp.), ashes (*Fraxinus* spp.), eastern cottonwood (*Populus deltoides*), and pecans (*Carya illinoensis*). Virtually all of the original tallgrass prairies are gone as a result of cultivation and urbanization (Griffith, G. et al, 2007).

2.3 Soils

The only soil type within the proposed project area included the San Antonio clay loam, 1 to 3 percent slopes. The San Antonio clay loam consists of well drained soils that formed in stream terraces weathered from loamy alluvium of quaternary age derived from mixed sources. The runoff class is high and there is no frequency of ponding or flooding. These soils are considered prime farmland. These soil are not considered hydric. Their ecological site classification is Eastern Clay Loam.

2.4 Geology

The proposed site's geology is the Wilcox Group, undivided. It is mostly mudstone, with various amounts of sandstone, lignite, ironstone concretions, and glauconitic. Total thickness is roughly 1,400-1,800 feet (*Bureau of Economic Geology, 1974*).

2.5 Climate

The area has average January minimum temperature of 40°F and maximum of 61°F and July temperature minimum of 72°F and maximum of 94°F, and this ecoregion has between 230 to 270 annual frost free days (*Griffith, G., et al, 2007*). This ecoregion receives 42 inches of rainfall on an annual basis.

3 ENVIRONMENTAL IMPACTS DESKTOP REVIEW

3.1 Potential Impacted Species and Migratory Birds

3.1.1 Threatened/Endangered Species

The Endangered Species Act (ESA) aims to conserve endangered and threatened species and the ecosystems they depend on. To implement the ESA, NOAA works with U.S. Fish and Wildlife Service (USFWS) and other federal, tribal, state, and local agencies, as well as nongovernmental organizations and private citizens.

The USFWS IPaC tool (*IPAC, n.d.*) lists three bird species, one as endangered and two as threatened, one amphibian species as threatened, one fish species as endangered, and eight insect species as endangered (**Attachment 3**). The Texas Parks and Wildlife Department (TPWD) lists two mammal species as threatened, two birds as threatened and three as endangered, two amphibian species as threatened, two fish species as threatened, one mollusk species as threatened, and three reptiles as threatened. In addition, TPWD included six endangered arachnid species and three endangered insect species.

The golden-cheeked warbler (*Setophaga chrysoparia*) is an endangered species that nests in mixed Ashe-juniper and oak woodlands in ravines and canyons. They use long strips of cedar bark and spider webs to build their nests. Sufficient habitat was not present on the project site.

The whooping crane (*Grus americana*) is an endangered species that prefers small ponds, marshes, and flooded grain fields for both roosting and foraging. This species is a migrant throughout most of the state. Sufficient habitat was not present within the project site.

The piping plover (*Charadrius melodus*) is a threatened species that prefers sand flats and algal flats. Optimal sites appear to be large in area, sparsely vegetated, continuously available or in close proximity to secondary habitat and with limited human disturbance. This species is not expected to occur within the project site.

The red knot (*Calidris canutus rufa*) is a threatened species that prefers seacoast on tidal flats and beaches and herbaceous wetlands. This species is not expected to occur within the project site.

The white-faced ibis (*Plegadis chihi*) is a state-listed species that prefers freshwater marshes, sloughs, and irrigated rice fields. This species currently resided in near-coastal rookeries. This species is not expected to occur within the project site.

The wood stork (*Mycteria americana*) is a state-listed species that prefers to nest in large tracts of cypress swamps and red mangrove swamps. This species is not expected to occur within the project site.

The San Marcos salamander (*Eurycea nana*) is federally listed threatened species. This species is an aquatic, lungless salamander endemic to Spring Lake and a small region of the headwaters of the San Marcos River near Aquarena Springs. This species is not expected to occur within the project area.

The Cascade Caverns salamander (*Eurycea latitans*) and Texas salamander (*Eurycea neotenes*) are state-listed threatened species. These species are aquatic species that lives in springs, streams, and caves with rocky or cobble beds.

The USFWS and TPWD included six endangered arachnid species as occurring in Bexar County. These species occur in karst features in northwest Bexar County. As such, these species are not expected to occur within the project area.

The fountain darter (*Etheostoma fonticola*) is an endangered fish species. This species requires clean, spring-fed waters with bottom vegetation. Suitable habitat for this species is not present within the project site.

The toothless blindcat (*Trogloglanis pattersoni*) and widemouth blindcat (*Satan eurystomus*) are state-listed fish species. These species are restricted to five artesian wells penetrating the San Antonio Pool of the Edwards Aquifer. Suitable habitat for these species does not occur within the project area.

The USFWS listed three insect species as occurring within Bexar County. These species are karst species and are not expected to occur within the project site.

The black bear (*Ursus americana*) is a state-listed mammal species. This species prefers bottomland hardwoods, floodplain forests, upland hardwoods with mixed pine, and marsh. This species is not expected to occur within the project site.

The white-nosed coati (*Nasua narica*) is a state-listed mammal species. This species prefers woodlands, riparian corridors, and canyons. This species is not expected to occur within the project site.

The false spike (*Fusconaia mitchelli*) is a state-listed threatened species and is also proposed by the USFWS as endangered. This species occurs in small streams to medium-sized rivers in habitats such as riffles and runs with flowing water. Suitable habitat for this species is not present within the project site.

The Cagle's map turtle (*Graptemys caglei*) is a state-listed threatened aquatic reptile. This species prefers streams and rivers with moving water. Suitable habitat for this species is not present within the project site.

The Texas horned lizard (*Phrynosoma cornutum*) is a state-listed threatened reptile. This species prefers open habitats with sparse vegetation, including grass, prairie, cactus, scattered brush, or scrubby trees. Suitable habitat was not observed within the project site.

The Texas tortoise (*Gopherus berlandieri*) is a state-listed threatened reptile. This species prefers open scrub woods, arid brush, grass-cactus association, often in areas with sandy well-drained soils. Suitable habitat was not observed within the project site.

3.1.2 Candidate Species

The USFWS also lists the monarch butterfly (*Danaus plexippus*) as a potential candidate species. Candidate species are species that are being considered for possible addition to the threatened and endangered species list. They currently have no legal protection under the ESA. If you find you have potential project impacts to these species the USFWS can provide technical assistance to help avoid or minimize any adverse impacts.

Candidate Conservation Agreements (CCAs) are voluntary conservation agreements between the U.S. Fish and Wildlife Service (Service) and one or more public or private parties. The Service works with its partners to identify threats to candidate species, plan the measures needed to address the threats and conserve these species, identify willing landowners, develop agreements, and design and implement conservation measures and monitor their effectiveness. Candidate Conservation Agreements with Assurances (CCAAs) expand on the success of traditional CCAs by providing non-federal landowners with additional incentives for engaging in voluntary proactive conservation through assurances that limit future conservation obligations. One of the primary reasons for developing the CCAA program was to address landowner concerns about the potential regulatory implications of having a listed species on their land. The CCAA program specifically targets non-federal landowners and provides them with the assurance that if they implement various conservation activities, they will not be subject to additional restrictions if the species becomes listed under the ESA. These assurances are only available to non-federal entities for actions on non-federal lands.

If a candidate species is found at the proposed Site, implementing conservation efforts before species are listed increases the likelihood that simpler, flexible, and more cost-effective conservation options are available. For additional information regarding CCAs and CCAAs please contact the U. S. Fish and Wildlife Service Ecological Services Program or please see the below link for additional information:

<https://www.fws.gov/endangered/esa-library/pdf/CCAs.pdf>.

3.1.3 Migratory Birds

Certain birds are protected under the Migratory Bird Treaty Act (MBTA) and the Bald and Golden Eagle Protection Act (BGEPA). The Migratory Bird Treaty Act of 1918 provides protection for a large number of migratory bird species. The MBTA specifically is a treaty between the U.S., Japan, Canada, Mexico, and Russia which protect birds that migrate across international borders. The take of all migratory birds, including bald eagles, is governed by the MBTA regulations.

The MBTA prohibits the taking, killing, possession, transportation, and importation of migratory birds, their eggs, parts, and nests except as authorized under a valid permit. Additionally, the MBTA authorizes and directs the Secretary of the Interior to determine if, and by what means, the take of migratory birds should be allowed and to adopt suitable regulations permitting and governing take (for example, hunting seasons for ducks and geese). The bald eagle is protected by the BGEPA even though it has been delisted under the Endangered Species Act. This law, originally passed in 1940, provides for the protection of the bald eagle and the golden eagle (as amended in 1962) by prohibiting the take, possession, sale, purchase, barter, offer to sell, purchase or barter, transport, export or import, of any bald or golden eagle, alive or dead, including any part, nest, or egg, unless allowed by permit.

Any person or organization who plans or conducts activities that may result in impacts to migratory birds, eagles, and their habitats should follow appropriate regulations and consider implementing appropriate conservation measures. The birds in the below table are of particular concern either because they occur on the USFWS Birds of Conservation Concern (BCC) list or warrant special attention in the project location.

Please note, this is not a list of every bird you may find in this location, nor a guarantee that every bird on this list will be found in your project area:

Table 1. Potential Birds of Conservation Concern

Migratory Bird Species Name	Breeding Season	Level of Concern (BCC or ESA Status)
Lesser Yellowlegs (<i>Tringa flavipes</i>)	Breeds elsewhere	BCC Rangewide
Chimney Swift (<i>Chaetura pelagica</i>)	Breeds March 15 to Aug 25	BCC Rangewide
Little Blue Heron (<i>Egretta caerulea</i>)	Breeds March 10 to Oct 15	BCC in BCRs

When birds may be breeding in the area, identifying the locations of any active nests and avoiding their destruction is a very helpful impact minimization measure. Additional measures or permits may be advisable depending on the type of activity

Weaver Consultants Group, LLC

you are conducting, and the type of infrastructure or bird species present on your project site. If your project has the potential to disturb or kill eagles, you may need to obtain a permit to avoid violating the Eagle Act should such impacts occur.

Nationwide Conservation Measures (NCM) describes measures that can help avoid and minimize impacts to all birds at any location year-round. Implementation of these measures is particularly important when birds are most likely to occur in the project area. These measures are grouped into three categories: General, Habitat Protection, and Stressor Management. These measures may be updated through time. We recommend checking the USFWS NCM website regularly for the most up-to-date list:

<https://www.fws.gov/migratorybirds/pdf/management/nationwidestandardconservationmeasures.pdf>

Please note, if one of the birds in Table 1 is found at the proposed project site the MBTA prohibits the take (including killing, capturing, selling, trading, and transport) of protected migratory bird species without prior authorization by the USFWS. The MBTA is regulated by the USFWS. If a species is found, or an active nest is found, a permit from the USFWS must be obtained before take of the species can occur. The MBTA makes it illegal for anyone to take, possess, import, export, transport, sell, purchase, barter, or offer for sale, purchase, or barter, any migratory bird, or the parts, nests, or eggs of such a bird except under the terms of a valid permit issued pursuant to Federal regulations. The migratory bird species protected by the Act are listed in 50 CFR 10.13.

In addition to immediate impacts, this definition also covers impacts that result from human-induced alterations initiated around a previously used nest site during a time when eagles are not present under the BGEPA, if, upon the eagle's return, such alterations agitate or bother an eagle to a degree that interferes with or interrupts normal breeding, feeding, or sheltering habits, and causes injury, death or nest abandonment. A violation of the Act can result in a fine of \$100,000 (\$200,000 for organizations), imprisonment for one year, or both, for a first offense. Penalties increase substantially for additional offenses, and a second violation of this Act is a felony.

3.2 Observations

A field investigation was conducted of the proposed project site on May 19, 2023. The project site was occupied by a previous business operation and grassland. The dominant vegetation consisted of herbaceous species including plains coreopsis (*Coreopsis tinctoria*), Santa Maria feverfew (*Parthenium hysterophorus*), Texas vervain (*Verbena halei*), annual ragweed (*Ambrosia artemisifolia*), wild petunia (*Ruellia nudiflora*), rescuegrass (*Bromus catharticus*), threelobe false mallow (*Malvastrum coromandelianum*), white tridens (*Tridens albescens*), evening primrose

(*Oenothera speciosa*), Carolina canarygrass (*Phalaris caroliniana*), perennial ryegrass (*Lolium perenne*), Johnsongrass (*Sorghum halepense*), KR bluestem (*Bothriochloa ischaemum*), fiddle dock (*Rumex pulcher*), Texas wintergrass (*Nassella leucotricha*), peppergrass (*Lepidium* spp), prairie coneflower (*Ratibida columnifera*), Venus looking glass (*Triodanis perfoliata*), Texas thistle (*Cirsium texanum*), frogfruit (*Phyla nodiflora*), bermudagrass (*Cynodon dactylon*), lemon beebalm (*Monarda citriodora*), grass-leaved rush (*Juncus marginatus*), and mesquite (*Prosopis glandulosa*).

4 RESULTS AND RECOMMENDATIONS

4.1 Summary of Results and Recommendations

The proposed project site had an abandoned building with associated parking area that comprised approximately half the site. The remaining southern half of the property consisted of a dense stand of native grasses and forbs. No threatened or endangered species, nor their suitable habitat, were observed within the project site.

The proposed project will not result in the destruction or adverse modification of any federally designated critical habitat for any threatened or endangered species, nor cause or contribute to the taking of any listed threatened or endangered species. Please note, Table 1 provides a list of the Potential Birds of Conservation Concern list or warrant special attention in the project location and the Nationwide Conservation Measures (NCM) can help avoid and minimize impacts to all birds at any location year-round. If any birds listed in Table 1 or any other threatened/endangered species are found at the project location, the U. S. Fish and Wildlife Service Ecological Services Program and Texas Parks and Wildlife Department should be contacted. Based on this environmental review, no further investigation for threatened and endangered species is recommended at this time.

5 REFERENCES

Environmental Protection Agency (EPA), 2013, Level III and IV ecoregions of the continental United States: Corvallis, Oregon, U.S. EPA, National Health and Environmental Effects Research Laboratory, map scale 1:3,000,000, <https://www.epa.gov/eco-research/level-iii-and-iv-ecoregions-continental-united-states>.

U.S. Environmental Protection Agency, 2013, Level III ecoregions of the continental United States: Corvallis, Oregon, U.S. EPA – National Health and Environmental Effects Research Laboratory, map scale 1:7,500,000, http://www.epa.gov/wed/pages/ecoregions/level_iii_iv.htm.

Griffith, G., Griffith, S., Omernick, J., and Rogers, A., 2007, Ecoregions of Texas: Texas Commission on Environmental Quality.

IPaC - Information for Planning and Consultation, n.d., <https://ecos.fws.gov/ipac/>

Texas Parks and Wildlife Department, Accessed 4 January 2023, Bexar County: Annotated County Lists of Rare Species

ATTACHMENT 1
FIGURES

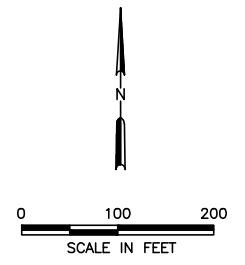
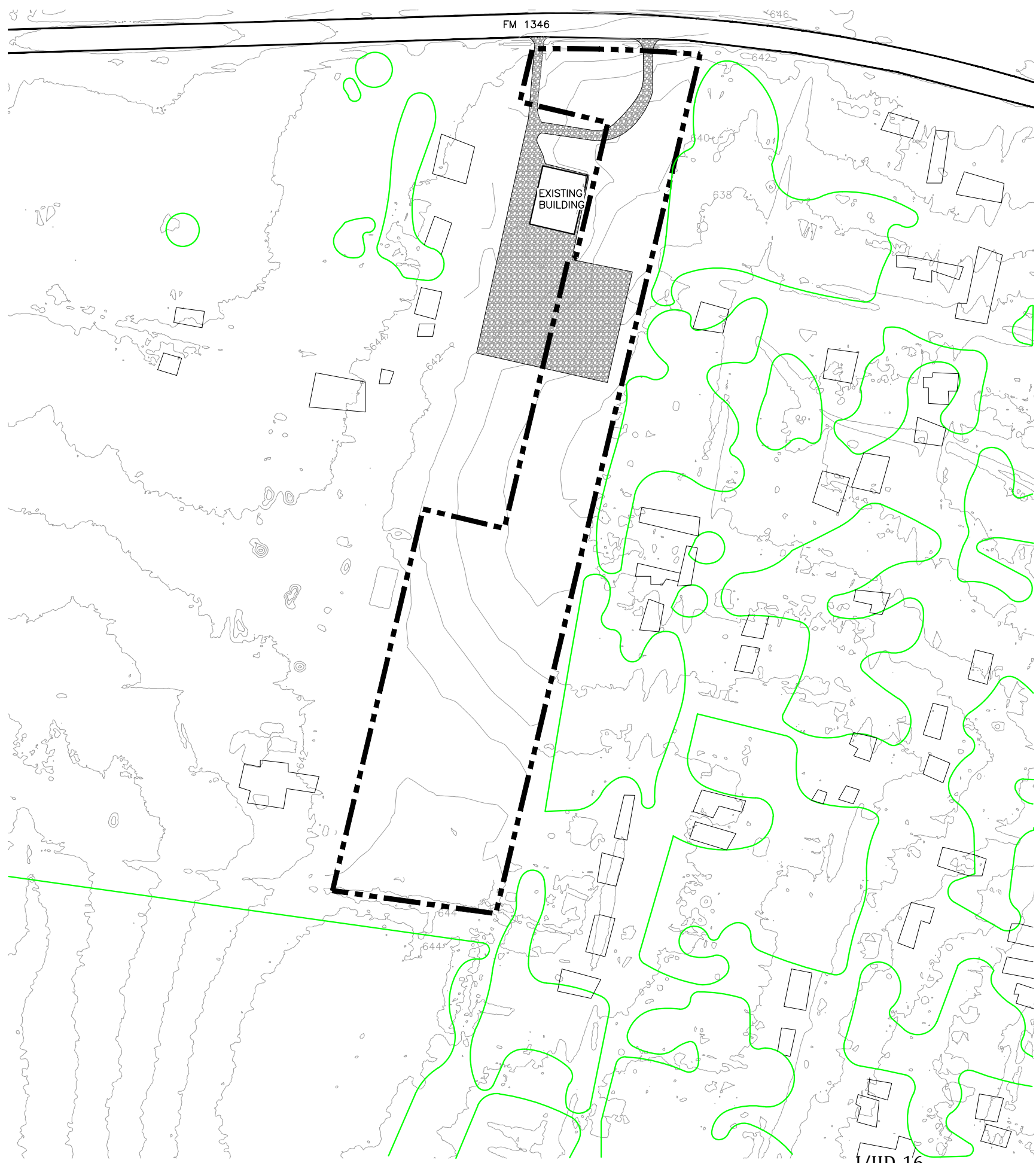

LEGEND

	REGISTRATION BOUNDARY (SEE NOTE 2)
	EXISTING CONTOUR (SEE NOTE 1)
	EXISTING GRAVEL
	EXISTING TREES
	EXISTING BUILDING

- NOTES:**
1. THE EXISTING CONTOURS PROVIDED BY TEXAS RESOURCE INFORMATION SYSTEM (TNRIS) BEXAR AND TRAVIS COUNTIES LIDAR, 2022 AND AN ONSITE SURVEY COMPLETED BY WEAVER CONSULTANTS GROUP LLC ON --
 2. THE REGISTRATION BOUNDARY WAS PREPARED BY WEAVER CONSULTANTS GROUP, DATED JUNE 6, 2023.

Tech. Complete App. - 244

<input type="checkbox"/> 90% REVIEW <input checked="" type="checkbox"/> FOR PERMITTING PURPOSES ONLY <input type="checkbox"/> ISSUED FOR CONSTRUCTION	PREPARED FOR	TEXAS REGIONAL LANDFILL COMPANY, LP TYPE V REGISTRATION APPLICATION EXISTING SITE CONDITIONS SAN ANTONIO TRANSFER STATION BEXAR COUNTY, TEXAS												
	DATE: 09/2023 FILE: 0601-012-11 CAD: FIG 3.1-EXISTING SITE CONDITIONS.DWG		DRAWN BY: RAA DESIGN BY: MB REVIEWED BY: CRM											
Weaver Consultants Group TBPE REGISTRATION NO. F-3727		REVISIONS <table border="1"> <thead> <tr> <th>NO.</th> <th>DATE</th> <th>DESCRIPTION</th> </tr> </thead> <tbody> <tr> <td> </td> <td> </td> <td> </td> </tr> <tr> <td> </td> <td> </td> <td> </td> </tr> <tr> <td> </td> <td> </td> <td> </td> </tr> </tbody> </table>	NO.	DATE	DESCRIPTION									
NO.	DATE	DESCRIPTION												
WWW.WCGRP.COM		FIGURE I/II-3.1												

0:\0601\12\TYPE V APPLICATION\PARTS I-II\FIG 3.1-EXISTING SITE CONDITIONS.dwg, mbahmani, 1:2

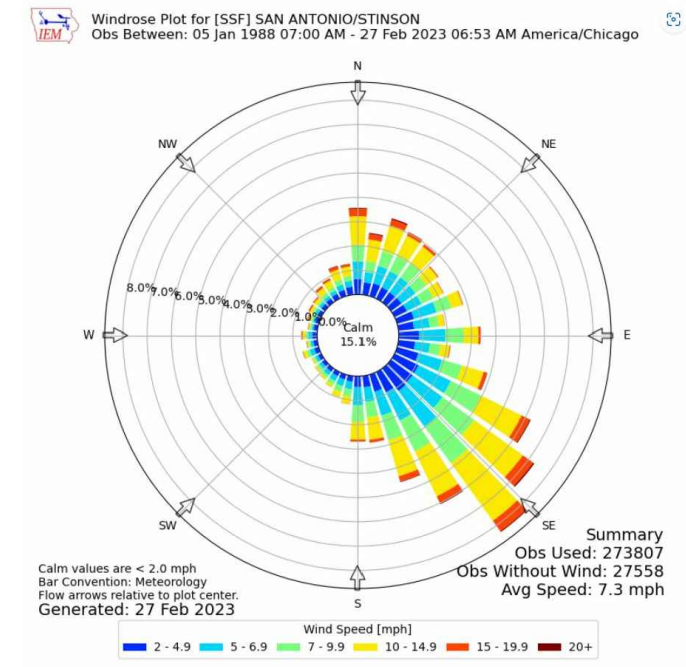
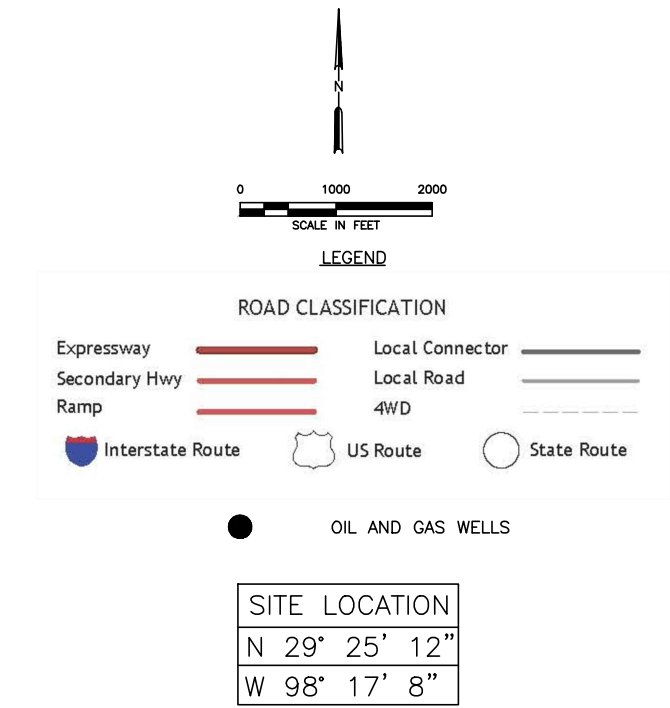
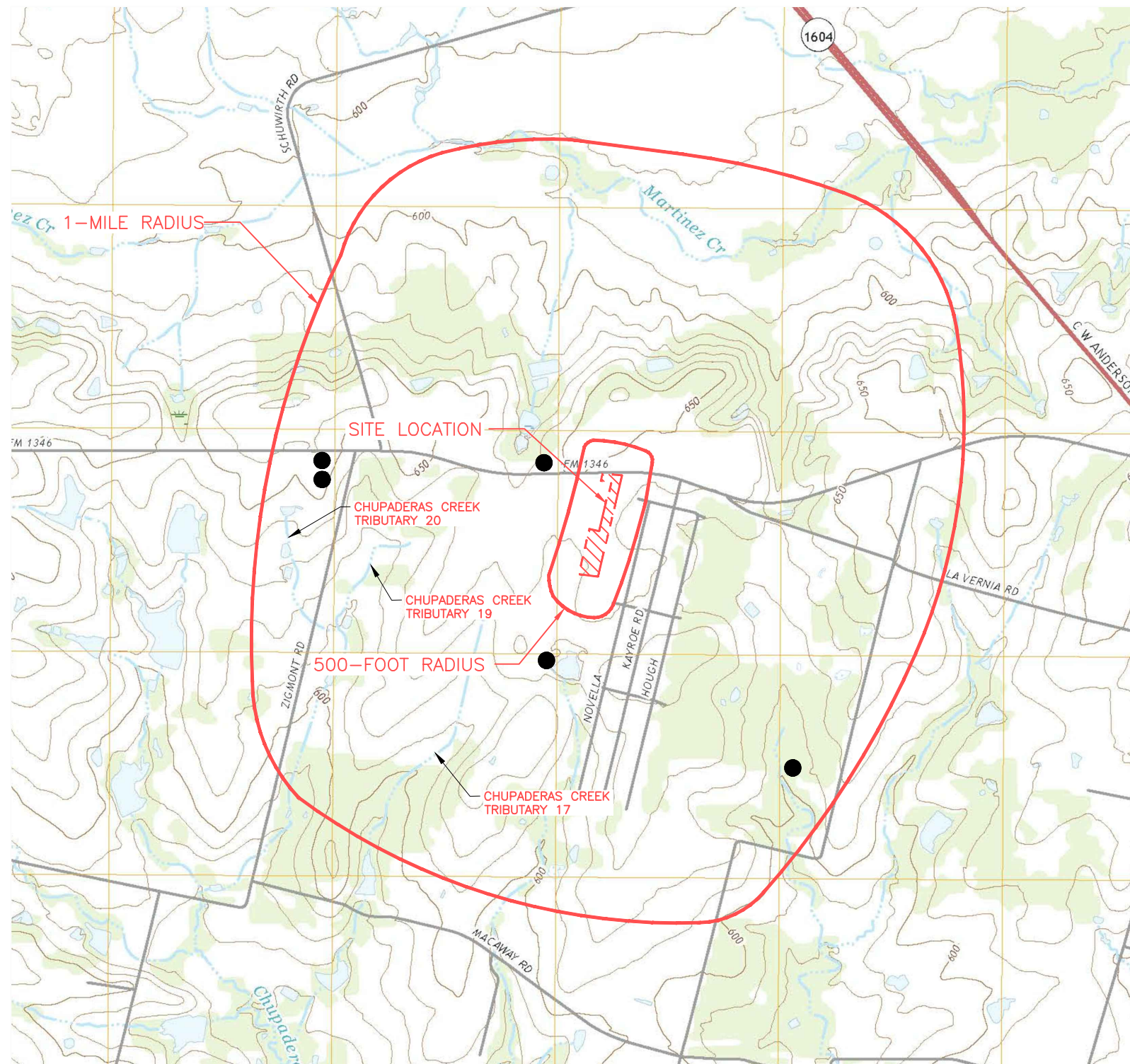

- NOTE:**
- ADAPTED FROM THE USGS 7.5 MINUTE QUADRANGLE TOPOGRAPHIC MAPS (MARTINEZ, TX 2022)
 - THERE ARE NO SPRINGS WITHIN 1 MILE OF THE SITE LOCATION.
 - OIL AND GAS LOCATIONS ARE PROVIDED BY ERIS DATABASE DATED FEBRUARY 7, 2023.

Tech. Complete App. - 246

<input type="checkbox"/> DRAFT <input checked="" type="checkbox"/> FOR PERMITTING PURPOSES ONLY <input type="checkbox"/> ISSUED FOR CONSTRUCTION	PREPARED FOR TEXAS REGIONAL LANDFILL COMPANY, LP	TYPE V REGISTRATION APPLICATION GENERAL TOPOGRAPHIC MAP SAN ANTONIO TRANSFER STATION BEXAR COUNTY, TEXAS					
	DATE: 09/2023 FILE: 0601-012-11 CAD: FIG 4.2-GENERAL TOPO MAP.DWG		DRAWN BY: RAA DESIGN BY: MB REVIEWED BY: CRM				
REVISIONS		WWW.WCGRP.COM					
<table border="1"> <thead> <tr> <th>NO.</th> <th>DATE</th> <th>DESCRIPTION</th> </tr> </thead> <tbody> <tr> <td> </td> <td> </td> <td> </td> </tr> </tbody> </table>			NO.	DATE	DESCRIPTION		
NO.	DATE	DESCRIPTION					
Weaver Consultants Group TBPE REGISTRATION NO. F-3727		FIGURE 1/II-4.2					

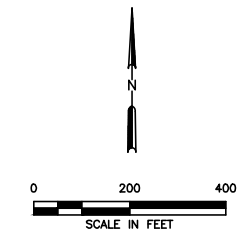

LEGEND

- — — — REGISTRATION BOUNDARY
- IB INHABITABLE STRUCTURES
- IC INDUSTRIAL/COMMERCIAL STRUCTURES
- R RESIDENCE
- CH CHURCH

NOTES:

1. AERIAL PHOTOGRAPH PROVIDED BY GOOGLE EARTH DATED AUGUST 9, 2022.
2. ALL STRUCTURES WITHIN 500 FEET OF THE PERMIT BOUNDARY ARE SHOWN ON THIS FIGURE.
3. THE NEAREST RESIDENCE IS LOCATED APPROXIMATELY 48 FEET EAST OF THE REGISTRATION BOUNDARY.

Tech. Complete App. - 247

<input type="checkbox"/> DRAFT <input checked="" type="checkbox"/> FOR PERMITTING PURPOSES ONLY <input type="checkbox"/> ISSUED FOR CONSTRUCTION	PREPARED FOR TEXAS REGIONAL LANDFILL COMPANY, LP	TYPE V REGISTRATION APPLICATION AERIAL PHOTOGRAPH													
DATE: 09/2023 FILE: 0601-012-11 CAD: FIG 6.1-AERIAL PHOTOGRAPH.DWG	DRAWN BY: SRF DESIGN BY: MB REVIEWED BY: CRM	REVISIONS <table border="1" style="width: 100%; border-collapse: collapse;"> <thead> <tr> <th style="width: 5%;">NO.</th> <th style="width: 10%;">DATE</th> <th style="width: 85%;">DESCRIPTION</th> </tr> </thead> <tbody> <tr><td> </td><td> </td><td> </td></tr> <tr><td> </td><td> </td><td> </td></tr> <tr><td> </td><td> </td><td> </td></tr> </tbody> </table>		NO.	DATE	DESCRIPTION									
NO.	DATE	DESCRIPTION													
Weaver Consultants Group TBPE REGISTRATION NO. F-3727		SAN ANTONIO TRANSFER STATION BEXAR COUNTY, TEXAS	WWW.WCGRP.COM FIGURE 1/II-4.3												

0:\0601\12\TYPE V APPLICATION\PARTS F-H\FIG 5.1-LAND OWNER MAP.dwg, mbahmann, 1:2

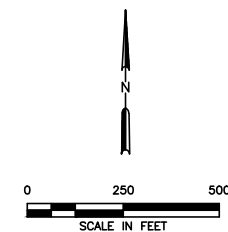

LEGEND

	REGISTRATION BOUNDARY
	PROPERTY BOUNDARY LINES
	PROPERTY OWNER DESIGNATION

- NOTES:**
1. PROPERTY BOUNDARIES AND OWNER INFORMATION PROVIDED BY BEXAR COUNTY TAX APPRAISAL WEBSITE, AND APPRAISAL DISTRICT RECORDS AS OF JULY 2023.
 - ① REFERS TO PROPERTY OWNERS LISTED ON PROPERTY OWNERS LIST IN SECTION 5, PROPERTY OWNERS LIST AND MAP.

Tech. Complete App. - 249

<input type="checkbox"/> DRAFT <input checked="" type="checkbox"/> FOR PERMITTING PURPOSES ONLY <input type="checkbox"/> ISSUED FOR CONSTRUCTION	PREPARED FOR TEXAS REGIONAL LANDFILL COMPANY, LP	TYPE V REGISTRATION APPLICATION LAND OWNER'S MAP																
DATE: 09/2023 FILE: 0601-012-11 CAD: FIG 5.1-LAND OWNER'S MAP.DWG	DRAWN BY: RAA DESIGN BY: MB REVIEWED BY: CRM	SAN ANTONIO TRANSFER STATION BEXAR COUNTY, TEXAS																
Weaver Consultants Group TBPE REGISTRATION NO. F-3727		<table border="1" style="width: 100%; border-collapse: collapse;"> <thead> <tr> <th colspan="3" style="text-align: center;">REVISIONS</th> </tr> <tr> <th style="width: 10%;">NO.</th> <th style="width: 10%;">DATE</th> <th>DESCRIPTION</th> </tr> </thead> <tbody> <tr><td> </td><td> </td><td> </td></tr> <tr><td> </td><td> </td><td> </td></tr> <tr><td> </td><td> </td><td> </td></tr> </tbody> </table>	REVISIONS			NO.	DATE	DESCRIPTION										WWW.WCGRP.COM
REVISIONS																		
NO.	DATE	DESCRIPTION																
I/II-21		FIGURE I/II-5.1																

0:\0601\12\TYPE V APPLICATION\PARTS 1-II\FIG 6.1-AERIAL PHOTOGRAPH.dwg, mbahmani, 1:2

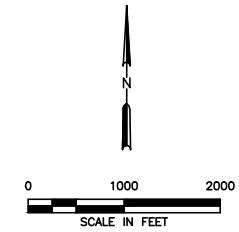
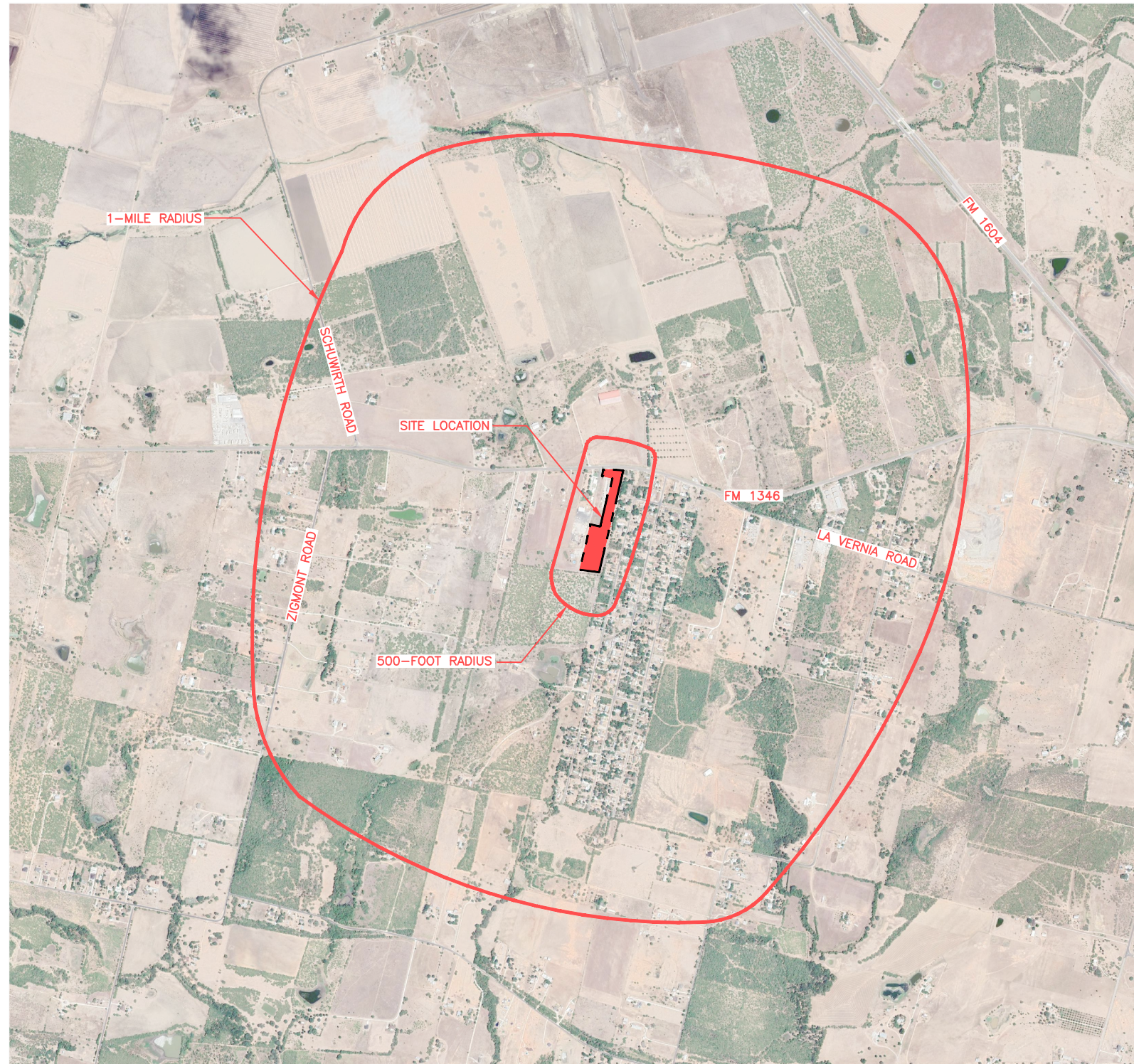

NOTES:
 1. AERIAL PHOTOGRAPH PROVIDED BY GOOGLE EARTH DATED AUGUST 09, 2022.

Tech. Complete App. - 250

<input type="checkbox"/> DRAFT <input checked="" type="checkbox"/> FOR PERMITTING PURPOSES ONLY <input type="checkbox"/> ISSUED FOR CONSTRUCTION	PREPARED FOR TEXAS REGIONAL LANDFILL COMPANY, LP		TYPE V REGISTRATION APPLICATION AERIAL PHOTOGRAPH SAN ANTONIO TRANSFER STATION BEXAR COUNTY, TEXAS											
	DATE: 09/2023 FILE: 0601-012-11 CAD: FIG 6.1-AERIAL PHOTOGRAPH.DWG	DRAWN BY: RAA DESIGN BY: MB REVIEWED BY: CRM		REVISIONS <table border="1"> <thead> <tr> <th>NO.</th> <th>DATE</th> <th>DESCRIPTION</th> </tr> </thead> <tbody> <tr> <td> </td> <td> </td> <td> </td> </tr> <tr> <td> </td> <td> </td> <td> </td> </tr> <tr> <td> </td> <td> </td> <td> </td> </tr> </tbody> </table>	NO.	DATE	DESCRIPTION							
NO.	DATE	DESCRIPTION												
Weaver Consultants Group TBPE REGISTRATION NO. F-3727		WWW.WCGRP.COM	FIGURE I/II-6.1											

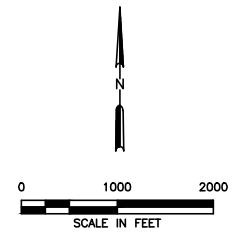

LEGEND

	PERMIT BOUNDARY
	1-MILE RADIUS
	RESIDENTIAL
	INDUSTRIAL/COMMERCIAL
	AGRICULTURAL/OPEN SPACE
	EXISTING STREAM

- NOTES:**
1. AERIAL PHOTOGRAPH PROVIDED BY GOOGLE EARTH DATED AUGUST 09, 2022.
 2. LAND USE IS SHOWN ONLY WITHIN THE 1-MILE BOUNDARY.
 3. SITE ACCESS ROADS WITHIN 1 MILE OF THE SITE INCLUDE FM 1346.
 4. EXCEPT AS OTHERWISE SHOWN, LAND USE IS PREDOMINANTLY AGRICULTURAL, INDUSTRIAL/COMMERCIAL, AND RESIDENTIAL.
 5. REFER TO FIGURE I/II-4.3 FOR INFORMATION REGARDING STRUCTURES AND INHABITABLE BUILDINGS WITHIN 500 FEET OF THE PERMIT BOUNDARY.
 6. THERE ARE NO LAKES, AND SEVERAL SMALL PONDS WITHIN THE 1-MILE RADIUS.
 7. ALL PAVED ROADS TO BE USED NORMALLY BY TRLC TO ACCESS THE FACILITY WITHIN THE 1-MILE RADIUS ARE EITHER ASPHALT OR CONCRETE.

Tech. Complete App. - 251

<input type="checkbox"/> DRAFT <input checked="" type="checkbox"/> FOR PERMITTING PURPOSES ONLY <input type="checkbox"/> ISSUED FOR CONSTRUCTION	PREPARED FOR TEXAS REGIONAL LANDFILL COMPANY, LP		TYPE V PERMIT AMENDMENT APPLICATION LAND USE MAP SAN ANTONIO TRANSFER STATION BEXAR COUNTY, TEXAS								
	DATE: 09/2023 FILE: 0601-012-11 CAD: FIG 7.1-LAND USE MAP.DWG	DRAWN BY: RAA DESIGN BY: MB REVIEWED BY: CRM		REVISIONS <table border="1"> <thead> <tr> <th>NO.</th> <th>DATE</th> <th>DESCRIPTION</th> </tr> </thead> <tbody> <tr> <td> </td> <td> </td> <td> </td> </tr> <tr> <td> </td> <td> </td> <td> </td> </tr> </tbody> </table>	NO.	DATE	DESCRIPTION				
NO.	DATE	DESCRIPTION									
Weaver Consultants Group TBPE REGISTRATION NO. F-3727			WWW.WCGRP.COM FIGURE I/II-7.1								

0:\0601\12\TYPE V APPLICATION\PARTS 1-II\FIG 7.2-CITIES WITHIN 5-MILE RADIUS.dwg, mbabhani, 1:2

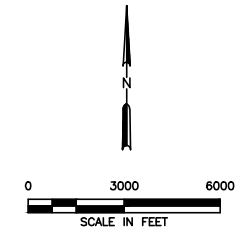
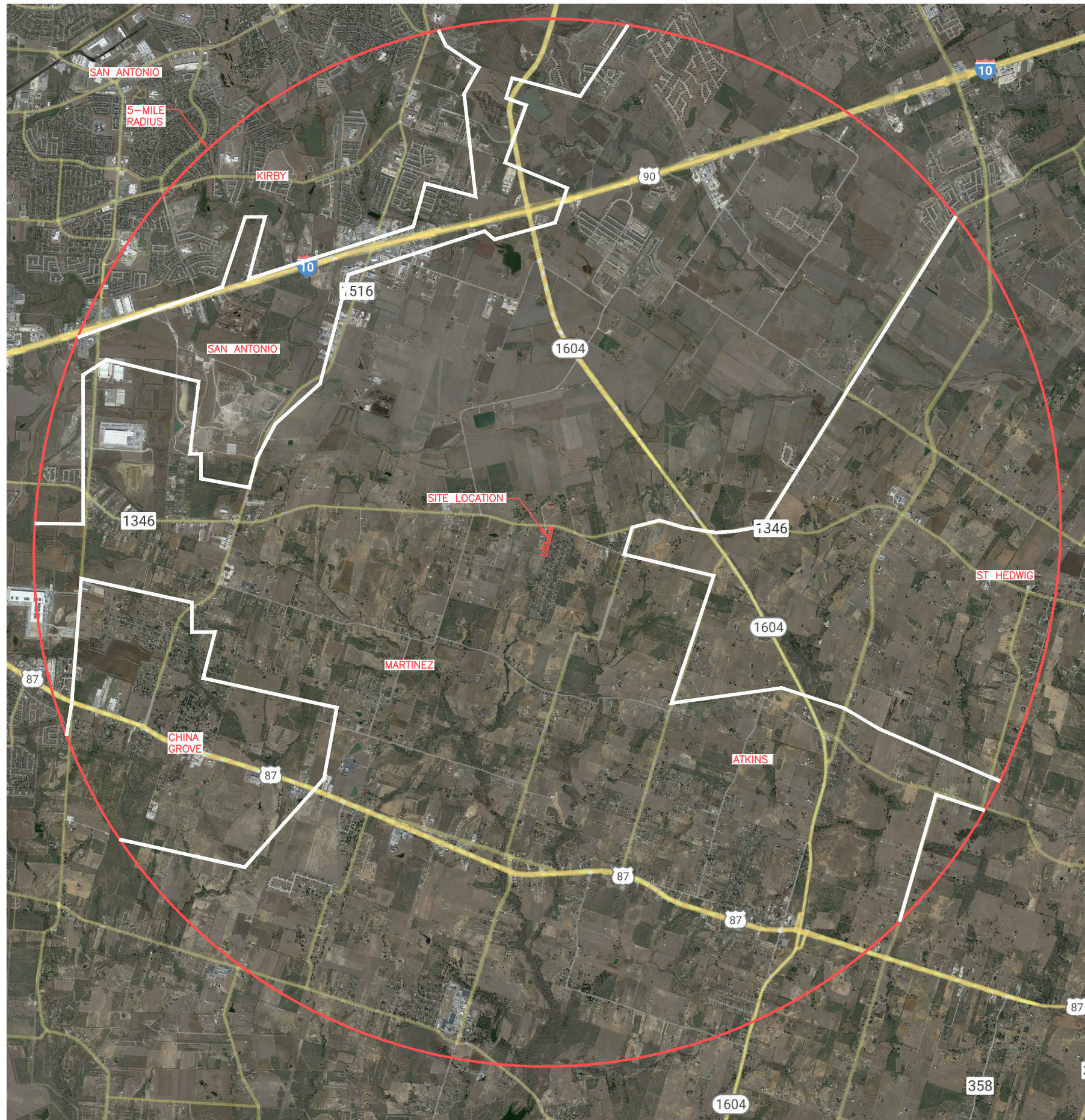

NOTES:

1. AERIAL PHOTOGRAPH PROVIDED BY GOOGLE EARTH DATED DECEMBER 16, 2020.
2. MARTINEZ AND ATKINS ARE UNINCORPORATED COMMUNITIES IN BEXAR COUNTY.

Tech. Complete App. - 252

<input type="checkbox"/> DRAFT <input checked="" type="checkbox"/> FOR PERMITTING PURPOSES ONLY <input type="checkbox"/> ISSUED FOR CONSTRUCTION	PREPARED FOR		TEXAS REGIONAL LANDFILL COMPANY, LP TYPE V REGISTRATION APPLICATION CITIES WITHIN 5-MILE RADIUS SAN ANTONIO TRANSFER STATION BEXAR COUNTY, TEXAS												
	DATE: 09/2023 FILE: 0601-012-11 CAD: FIG 7.2-CITIES WITHIN 5-MILES.DWG			DRAWN BY: RAA DESIGN BY: MB REVIEWED BY: CRM											
Weaver Consultants Group TBPE REGISTRATION NO. F-3727		REVISIONS <table border="1"> <thead> <tr> <th>NO.</th> <th>DATE</th> <th>DESCRIPTION</th> </tr> </thead> <tbody> <tr> <td> </td> <td> </td> <td> </td> </tr> <tr> <td> </td> <td> </td> <td> </td> </tr> <tr> <td> </td> <td> </td> <td> </td> </tr> </tbody> </table>	NO.	DATE	DESCRIPTION										WWW.WCGRP.COM FIGURE 1/II-7.2
NO.	DATE	DESCRIPTION													

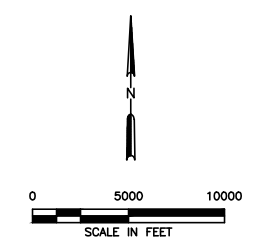
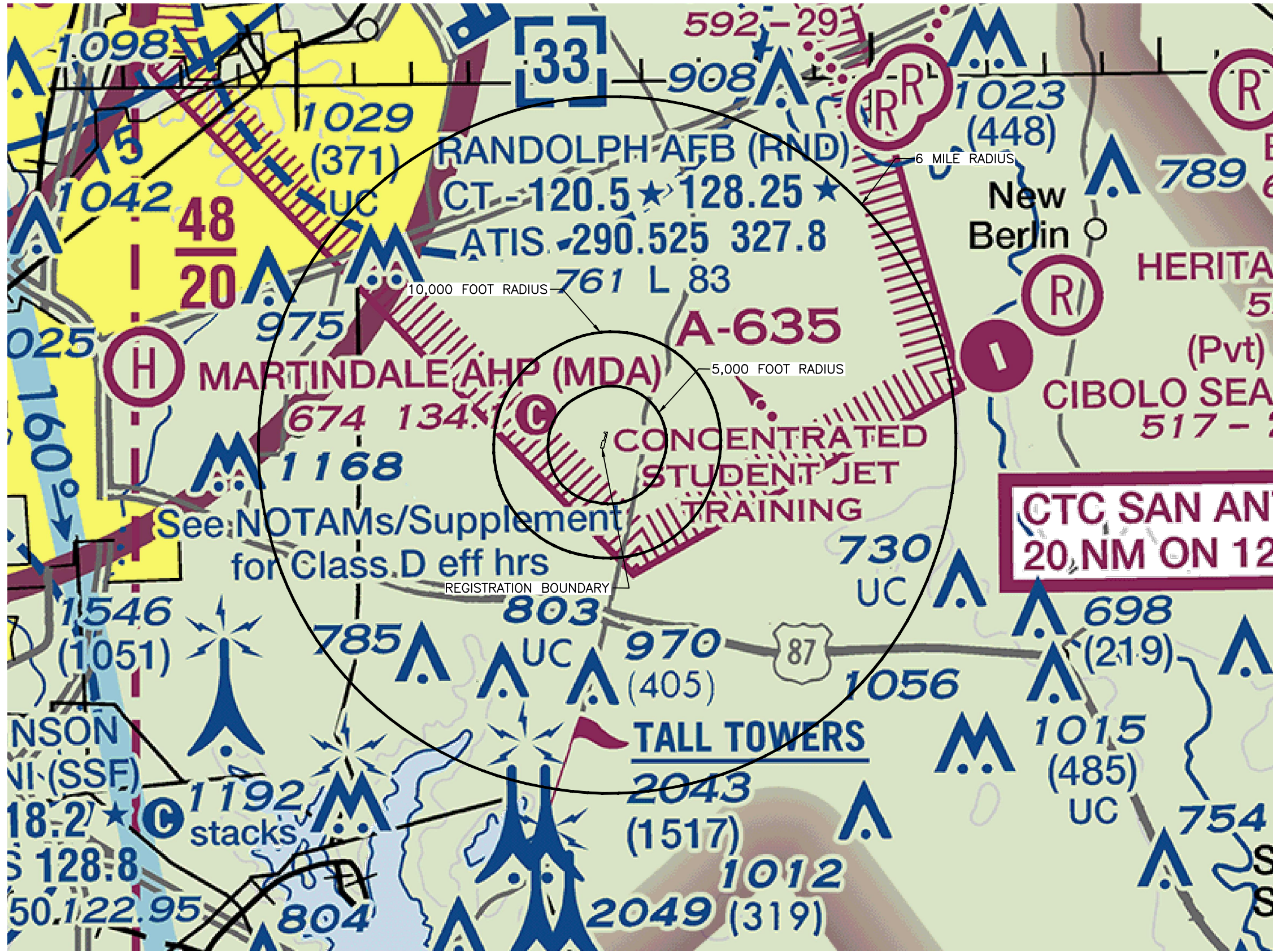

LEGEND

AIRPORTS

- Other than hard-surfaced runways
- Hard-surfaced runways 1500 ft. to 8069 ft. in length
- Hard-surfaced runways greater than 8069 ft. or some multiple runways less than 8069 ft.
- Open dot within hard-surfaced runway configuration indicates approximate VOR, VOR-DME, DME or VORTAC location.
- All recognizable hard-surfaced runways, including those closed, are shown for visual identification. Airports may be public or private.

ADDITIONAL AIRPORT INFORMATION

- Private "(Pvt)" - Non-public use having landmark value
- Military - Other than hard-surfaced; all military airports are identified by abbreviations AFB, NAS, AAF, etc.
- Heliport Selected
- Unverified
- Abandoned - paved having landmark value, 3000 ft. or greater
- Ultraflight Flight Park Selected

Fuel availability indicated by use of tick marks around basic airport symbol. Consult Supplement for details and availability at airports with hard-surfaced runways greater than 8069 ft.

★ Rotating airport beacon in operation Sunset to Sunrise

OBJECTIONABLE - Airport may adversely affect airspace use.

***Alert Area and Military Operations Area (MOA)**
(may be lit or unlit)

OBSTRUCTIONS
(may be lit or unlit)

- 1000 ft and higher AGL
- Above 200 ft & below 1000 ft AGL (above 299 ft AGL in urban area)
- Obstruction with high-intensity lights; may operate part-time
- Wind Turbine Farm
- Wind Turbine
- Group Obstruction
- Under construction or reported position and elevation unverified
- NOTICE: Guy wires may extend outward from structures.

TOPOGRAPHIC INFORMATION

- Power Transmission Line
- Aerial Cable
- Lookout Tower
- 618 (Elevation Base of Tower)
- Mountain Pass
- 71823 (Elevation of Pass)
- Pass symbol does not indicate a recommended route or direction of flight and pass elevation does not indicate a recommended clearance altitude. Hazardous flight conditions may exist within and near mountain passes.

- NOTES:**
- THIS MAP REPRODUCED FROM THE FAA SAN ANTONIO SECTIONAL AERONAUTICAL CHART EDITION DATED JUNE 15, 2023.
 - THE NEAREST AIRPORTS TO THE REGISTRATION BOUNDARY ARE STINSON-MISSION MUNICIPAL AIRPORT LOCATED 12 MILES SOUTHWEST, AND SAN ANTONIO INTERNATIONAL LOCATED 13 MILES NORTHWEST.

Tech. Complete App. - 253

0:\0601\12\TYPE V APPLICATION\PARTS I-II\FIG 8.1-AIRPORT MAP.dwg, mbahmani, 1:2

<input type="checkbox"/> DRAFT <input checked="" type="checkbox"/> FOR INFORMATION PURPOSES ONLY <input type="checkbox"/> ISSUED FOR CONSTRUCTION	PREPARED FOR TEXAS REGIONAL LANDFILL COMPANY, LP		TYPE V REGISTRATION APPLICATION AREA AIRPORTS SAN ANTONIO TRANSFER STATION BEXAR COUNTY, TEXAS											
	DATE: 09/2023 FILE: 0601-012-11 CAD: FIG I/II-8.1-AREA AIRPORTS.DWG	DRAWN BY: RAA DESIGN BY: MB REVIEWED BY: CRM		REVISIONS <table border="1"> <thead> <tr> <th>NO.</th> <th>DATE</th> <th>DESCRIPTION</th> </tr> </thead> <tbody> <tr><td> </td><td> </td><td> </td></tr> <tr><td> </td><td> </td><td> </td></tr> <tr><td> </td><td> </td><td> </td></tr> </tbody> </table>	NO.	DATE	DESCRIPTION							
NO.	DATE	DESCRIPTION												
Weaver Consultants Group TBPE REGISTRATION NO. F-3727		WWW.WCGRP.COM	FIGURE I/II-8.1											

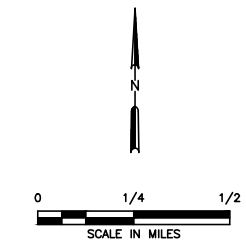

LEGEND

----- PERMIT BOUNDARY	
SPECIAL FLOOD HAZARD AREAS	Without Base Flood Elevation (BFE) Zone A, AE, AH, AR With BFE or Depth Zone AE, AH, AR, VE, AR
	Regulatory Floodway
OTHER AREAS OF FLOOD HAZARD	0.2% Annual Chance Flood Hazard, Areas of 1% annual chance flood with average depth less than one foot or with drainage areas of less than one square mile Zone X
	Future Conditions 1% Annual Chance Flood Hazard Zone X
	Area with Reduced Flood Risk due to Levee See Notes Zone X
OTHER AREAS	Area with Flood Risk due to Levee Zone D
	NO SCREEN Area of Minimal Flood Hazard Zone X
OTHER AREAS	Effective LOMRs
	Area of Undetermined Flood Hazard Zone D
GENERAL STRUCTURES	Channel, Culvert, or Storm Sewer
	Levee, Dike, or Floodwall
OTHER FEATURES	20.2 Cross Sections with 1% Annual Chance Water Surface Elevation
	17.5 Coastal Transect
	Coastal Transect Baseline
	Profile Baseline
	Hydrographic Feature
	Base Flood Elevation Line (BFE)
	Limit of Study
	Jurisdiction Boundary

- NOTES:**
- FLOODPLAIN INFORMATION PROVIDED BY FEMA FIRM PANEL 48029C0445G FOR BEXAR COUNTY, TEXAS AND INCORPORATED AREAS DATED SEPTEMBER 29, 2010.

Tech. Complete App. - 254

<input type="checkbox"/> DRAFT <input checked="" type="checkbox"/> FOR PERMITTING PURPOSES ONLY <input type="checkbox"/> ISSUED FOR CONSTRUCTION	PREPARED FOR	TEXAS REGIONAL LANDFILL COMPANY, LP TYPE V REGISTRATION APPLICATION FLOOD INSURANCE RATE MAP SAN ANTONIO TRANSFER STATION BEXAR COUNTY, TEXAS									
	DATE: 09/2023 FILE: 0601-012-11 CAD: FIG 11.1-FIRM.DWG		DESIGN BY: RAA DESIGN BY: MB REVIEWED BY: CRM								
Weaver Consultants Group TBPE REGISTRATION NO. F-3727		REVISIONS <table border="1"> <thead> <tr> <th>NO.</th> <th>DATE</th> <th>DESCRIPTION</th> </tr> </thead> <tbody> <tr> <td> </td> <td> </td> <td> </td> </tr> <tr> <td> </td> <td> </td> <td> </td> </tr> </tbody> </table>	NO.	DATE	DESCRIPTION						
NO.	DATE	DESCRIPTION									
WWW.WCGRP.COM		FIGURE 1/II-11.1									

0:\0601\12\TYPE V APPLICATION\PARTS 1-11\FIG 11.1-FIRM.dwg, mabhatmani, 1:2

ATTACHMENT 2
SITE PHOTOGRAPHS



Photo 1 – View of the building on the subject property.



Photo 2 – View looking south along the west boundary.



Photo 3 – View looking east along the southern edge of existing development.



Photo 4 – View of parking area on subject property.



Photo 5 – View of rangeland comprising the southern portion of the subject property.



Photo 6 – View from the south end looking north at subject property.

ATTACHMENT 3
USFWS IPAC SPECIES LIST

IPaC resource list

This report is an automatically generated list of species and other resources such as critical habitat (collectively referred to as *trust resources*) under the U.S. Fish and Wildlife Service's (USFWS) jurisdiction that are known or expected to be on or near the project area referenced below. The list may also include trust resources that occur outside of the project area, but that could potentially be directly or indirectly affected by activities in the project area. However, determining the likelihood and extent of effects a project may have on trust resources typically requires gathering additional site-specific (e.g., vegetation/species surveys) and project-specific (e.g., magnitude and timing of proposed activities) information.

Below is a summary of the project information you provided and contact information for the USFWS office(s) with jurisdiction in the defined project area. Please read the introduction to each section that follows (Endangered Species, Migratory Birds, USFWS Facilities, and NWI Wetlands) for additional information applicable to the trust resources addressed in that section.

Location

Bexar County, Texas



Local office

Austin Ecological Services Field Office

☎ (512) 937-7371

1505 Ferguson Lane

Austin, TX 78754-4501

NOT FOR CONSULTATION

Endangered species

This resource list is for informational purposes only and does not constitute an analysis of project level impacts.

The primary information used to generate this list is the known or expected range of each species. Additional areas of influence (AOI) for species are also considered. An AOI includes areas outside of the species range if the species could be indirectly affected by activities in that area (e.g., placing a dam upstream of a fish population even if that fish does not occur at the dam site, may indirectly impact the species by reducing or eliminating water flow downstream). Because species can move, and site conditions can change, the species on this list are not guaranteed to be found on or near the project area. To fully determine any potential effects to species, additional site-specific and project-specific information is often required.

Section 7 of the Endangered Species Act **requires** Federal agencies to "request of the Secretary information whether any species which is listed or proposed to be listed may be present in the area of such proposed action" for any project that is conducted, permitted, funded, or licensed by any Federal agency. A letter from the local office and a species list which fulfills this requirement can **only** be obtained by requesting an official species list from either the Regulatory Review section in IPaC (see directions below) or from the local field office directly.

For project evaluations that require USFWS concurrence/review, please return to the IPaC website and request an official species list by doing the following:

1. Draw the project location and click CONTINUE.
2. Click DEFINE PROJECT.
3. Log in (if directed to do so).
4. Provide a name and description for your project.
5. Click REQUEST SPECIES LIST.

Listed species¹ and their critical habitats are managed by the [Ecological Services Program](#) of the U.S. Fish and Wildlife Service (USFWS) and the fisheries division of the National Oceanic and Atmospheric Administration (NOAA Fisheries²).

Species and critical habitats under the sole responsibility of NOAA Fisheries are **not** shown on this list. Please contact [NOAA Fisheries](#) for [species under their jurisdiction](#).

-
1. Species listed under the [Endangered Species Act](#) are threatened or endangered; IPaC also shows species that are candidates, or proposed, for listing. See the [listing status page](#) for more information. IPaC only shows species that are regulated by USFWS (see FAQ).

2. [NOAA Fisheries](#), also known as the National Marine Fisheries Service (NMFS), is an office of the National Oceanic and Atmospheric Administration within the Department of Commerce.

The following species are potentially affected by activities in this location:

Mammals

NAME	STATUS
<p>Tricolored Bat <i>Perimyotis subflavus</i> Wherever found No critical habitat has been designated for this species. https://ecos.fws.gov/ecp/species/10515</p>	Proposed Endangered

Birds

NAME	STATUS
<p>Golden-cheeked Warbler <i>Setophaga chrysoparia</i> Wherever found No critical habitat has been designated for this species. https://ecos.fws.gov/ecp/species/33</p>	Endangered
<p>Piping Plover <i>Charadrius melodus</i> This species only needs to be considered if the following condition applies: <ul style="list-style-type: none"> Wind Energy Projects There is final critical habitat for this species. Your location does not overlap the critical habitat. https://ecos.fws.gov/ecp/species/6039</p>	Threatened
<p>Red Knot <i>Calidris canutus rufa</i> Wherever found This species only needs to be considered if the following condition applies: <ul style="list-style-type: none"> Wind Energy Projects There is proposed critical habitat for this species. https://ecos.fws.gov/ecp/species/1864</p>	Threatened

Amphibians

NAME	STATUS
------	--------

San Marcos Salamander *Eurycea nana*

Threatened

Wherever found

There is **final** critical habitat for this species. Your location does not overlap the critical habitat.

<https://ecos.fws.gov/ecp/species/6374>

Fishes

NAME

STATUS

Fountain Darter *Etheostoma fonticola*

Endangered

Wherever found

There is **final** critical habitat for this species. Your location does not overlap the critical habitat.

<https://ecos.fws.gov/ecp/species/5858>

Insects

NAME

STATUS

[no Common Name] Beetle *Rhadine exilis*

Endangered

Wherever found

There is **final** critical habitat for this species. Your location does not overlap the critical habitat.

<https://ecos.fws.gov/ecp/species/6942>

[no Common Name] Beetle *Rhadine infernalis*

Endangered

Wherever found

There is **final** critical habitat for this species. Your location does not overlap the critical habitat.

<https://ecos.fws.gov/ecp/species/3804>

Helotes Mold Beetle *Batrisodes venyivi*

Endangered

Wherever found

There is **final** critical habitat for this species. Your location does not overlap the critical habitat.

<https://ecos.fws.gov/ecp/species/1149>

Monarch Butterfly *Danaus plexippus*

Candidate

Wherever found

No critical habitat has been designated for this species.

<https://ecos.fws.gov/ecp/species/9743>

Arachnids

NAME	STATUS
<p>Cokendolpher Cave Harvestman <i>Texella cokendolpheri</i> Wherever found There is final critical habitat for this species. Your location does not overlap the critical habitat. https://ecos.fws.gov/ecp/species/676</p>	Endangered
<p>Government Canyon Bat Cave Meshweaver <i>Cicurina vespera</i> Wherever found There is final critical habitat for this species. Your location does not overlap the critical habitat. https://ecos.fws.gov/ecp/species/7037</p>	Endangered
<p>Government Canyon Bat Cave Spider <i>Tayshaneta microps</i> Wherever found There is final critical habitat for this species. Your location does not overlap the critical habitat. https://ecos.fws.gov/ecp/species/553</p>	Endangered
<p>Madla Cave Meshweaver <i>Cicurina madla</i> Wherever found There is final critical habitat for this species. Your location does not overlap the critical habitat. https://ecos.fws.gov/ecp/species/2467</p>	Endangered
<p>Robber Baron Cave Meshweaver <i>Cicurina baronia</i> Wherever found There is final critical habitat for this species. Your location does not overlap the critical habitat. https://ecos.fws.gov/ecp/species/2361</p>	Endangered

Critical habitats

Potential effects to critical habitat(s) in this location must be analyzed along with the endangered species themselves.

There are no critical habitats at this location.

You are still required to determine if your project(s) may have effects on all above listed species.

Migratory birds

Certain birds are protected under the Migratory Bird Treaty Act¹ and the Bald and Golden Eagle Protection Act².

Any person or organization who plans or conducts activities that may result in impacts to migratory birds, eagles, and their habitats should follow appropriate regulations and consider implementing appropriate conservation measures, as described [below](#).

1. The [Migratory Birds Treaty Act](#) of 1918.
2. The [Bald and Golden Eagle Protection Act](#) of 1940.

Additional information can be found using the following links:

- Birds of Conservation Concern <https://www.fws.gov/program/migratory-birds/species>
- Measures for avoiding and minimizing impacts to birds <https://www.fws.gov/library/collections/avoiding-and-minimizing-incident-take-migratory-birds>
- Nationwide conservation measures for birds <https://www.fws.gov/sites/default/files/documents/nationwide-standard-conservation-measures.pdf>

The birds listed below are birds of particular concern either because they occur on the [USFWS Birds of Conservation Concern \(BCC\)](#) list or warrant special attention in your project location. To learn more about the levels of concern for birds on your list and how this list is generated, see the FAQ [below](#). This is not a list of every bird you may find in this location, nor a guarantee that every bird on this list will be found in your project area. To see exact locations of where birders and the general public have sighted birds in and around your project area, visit the [E-bird data mapping tool](#) (Tip: enter your location, desired date range and a species on your list). For projects that occur off the Atlantic Coast, additional maps and models detailing the relative occurrence and abundance of bird species on your list are available. Links to additional information about Atlantic Coast birds, and other important information about your migratory bird list, including how to properly interpret and use your migratory bird report, can be found [below](#).

For guidance on when to schedule activities or implement avoidance and minimization measures to reduce impacts to migratory birds on your list, click on the PROBABILITY OF PRESENCE SUMMARY at the top of your list to see when these birds are most likely to be present and breeding in your project area.

NAME	BREEDING SEASON
Chimney Swift <i>Chaetura pelagica</i> This is a Bird of Conservation Concern (BCC) throughout its range in the continental USA and Alaska.	Breeds Mar 15 to Aug 25

Lesser Yellowlegs *Tringa flavipes*

Breeds elsewhere

This is a Bird of Conservation Concern (BCC) throughout its range in the continental USA and Alaska.

<https://ecos.fws.gov/ecp/species/9679>

Little Blue Heron *Egretta caerulea*

Breeds Mar 10 to Oct 15

This is a Bird of Conservation Concern (BCC) only in particular Bird Conservation Regions (BCRs) in the continental USA

Probability of Presence Summary

The graphs below provide our best understanding of when birds of concern are most likely to be present in your project area. This information can be used to tailor and schedule your project activities to avoid or minimize impacts to birds. Please make sure you read and understand the FAQ "Proper Interpretation and Use of Your Migratory Bird Report" before using or attempting to interpret this report.

Probability of Presence (■)

Each green bar represents the bird's relative probability of presence in the 10km grid cell(s) your project overlaps during a particular week of the year. (A year is represented as 12 4-week months.) A taller bar indicates a higher probability of species presence. The survey effort (see below) can be used to establish a level of confidence in the presence score. One can have higher confidence in the presence score if the corresponding survey effort is also high.

How is the probability of presence score calculated? The calculation is done in three steps:

1. The probability of presence for each week is calculated as the number of survey events in the week where the species was detected divided by the total number of survey events for that week. For example, if in week 12 there were 20 survey events and the Spotted Towhee was found in 5 of them, the probability of presence of the Spotted Towhee in week 12 is 0.25.
2. To properly present the pattern of presence across the year, the relative probability of presence is calculated. This is the probability of presence divided by the maximum probability of presence across all weeks. For example, imagine the probability of presence in week 20 for the Spotted Towhee is 0.05, and that the probability of presence at week 12 (0.25) is the maximum of any week of the year. The relative probability of presence on week 12 is $0.25/0.25 = 1$; at week 20 it is $0.05/0.25 = 0.2$.
3. The relative probability of presence calculated in the previous step undergoes a statistical conversion so that all possible values fall between 0 and 10, inclusive. This is the probability of presence score.

To see a bar's probability of presence score, simply hover your mouse cursor over the bar.

Breeding Season (■)

Yellow bars denote a very liberal estimate of the time-frame inside which the bird breeds across its entire range. If there are no yellow bars shown for a bird, it does not breed in your project area.

Survey Effort (I)

Vertical black lines superimposed on probability of presence bars indicate the number of surveys performed for that species in the 10km grid cell(s) your project area overlaps. The number of surveys is expressed as a range, for example, 33 to 64 surveys.

To see a bar's survey effort range, simply hover your mouse cursor over the bar.

No Data (-)

A week is marked as having no data if there were no survey events for that week.

Survey Timeframe

Surveys from only the last 10 years are used in order to ensure delivery of currently relevant information. The exception to this is areas off the Atlantic coast, where bird returns are based on all years of available data, since data in these areas is currently much more sparse.

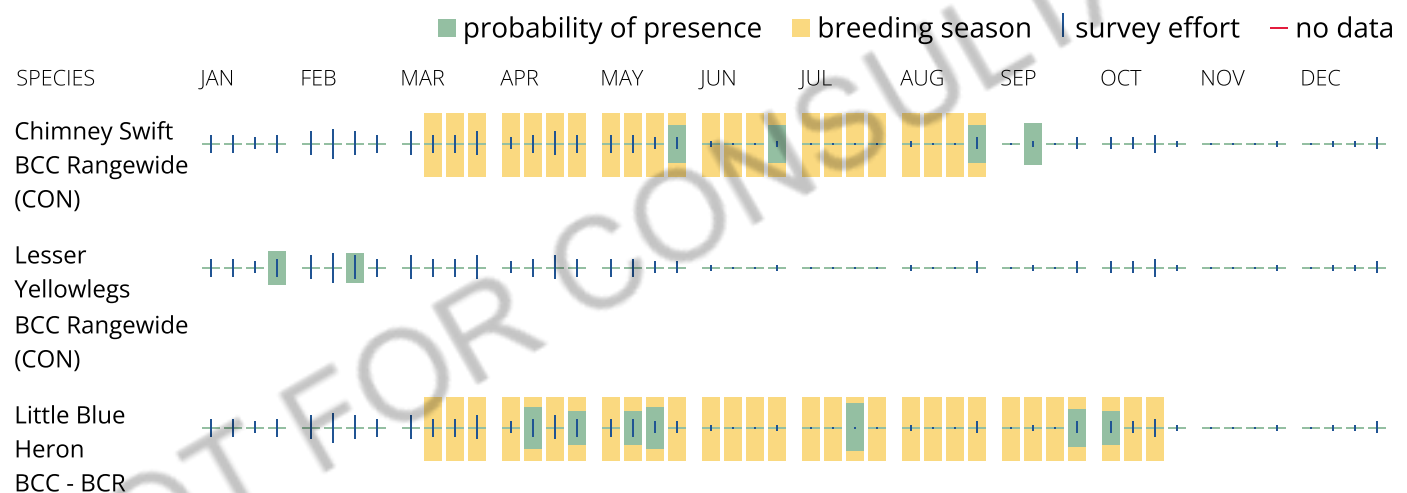

Tell me more about conservation measures I can implement to avoid or minimize impacts to migratory birds.

[Nationwide Conservation Measures](#) describes measures that can help avoid and minimize impacts to all birds at any location year round. Implementation of these measures is particularly important when birds are most likely to occur in the project area. When birds may be breeding in the area, identifying the locations of any active nests and avoiding their destruction is a very helpful impact minimization measure. To see when birds are most likely to occur and be breeding in your project area, view the Probability of Presence Summary. [Additional measures](#) or [permits](#) may be advisable depending on the type of activity you are conducting and the type of infrastructure or bird species present on your project site.

What does IPaC use to generate the list of migratory birds that potentially occur in my specified location?

The Migratory Bird Resource List is comprised of USFWS [Birds of Conservation Concern \(BCC\)](#) and other species that may warrant special attention in your project location.

The migratory bird list generated for your project is derived from data provided by the [Avian Knowledge Network \(AKN\)](#). The AKN data is based on a growing collection of [survey, banding, and citizen science datasets](#) and is queried and filtered to return a list of those birds reported as occurring in the 10km grid cell(s) which your project intersects, and that have been identified as warranting special attention because they are a BCC species in that area, an eagle ([Eagle Act](#) requirements may apply), or a species that has a particular vulnerability to offshore activities or development.

Again, the Migratory Bird Resource list includes only a subset of birds that may occur in your project area. It is not representative of all birds that may occur in your project area. To get a list of all birds potentially present in your project area, please visit the [Rapid Avian Information Locator \(RAIL\) Tool](#).

What does IPaC use to generate the probability of presence graphs for the migratory birds potentially occurring in my specified location?

The probability of presence graphs associated with your migratory bird list are based on data provided by the [Avian Knowledge Network \(AKN\)](#). This data is derived from a growing collection of [survey, banding, and citizen science datasets](#).

Probability of presence data is continuously being updated as new and better information becomes available. To learn more about how the probability of presence graphs are produced and how to interpret them, go to the Probability of Presence Summary and then click on the "Tell me about these graphs" link.

How do I know if a bird is breeding, wintering or migrating in my area?

To see what part of a particular bird's range your project area falls within (i.e. breeding, wintering, migrating or year-round), you may query your location using the [RAIL Tool](#) and look at the range maps provided for birds in your area at the bottom of the profiles provided for each bird in your results. If a bird on your migratory bird species list has a breeding season associated with it, if that bird does occur in your project area, there may be nests present at some point within the timeframe specified. If "Breeds elsewhere" is indicated, then the bird likely does not breed in your project area.

What are the levels of concern for migratory birds?

Migratory birds delivered through IPaC fall into the following distinct categories of concern:

1. "BCC Rangewide" birds are [Birds of Conservation Concern](#) (BCC) that are of concern throughout their range anywhere within the USA (including Hawaii, the Pacific Islands, Puerto Rico, and the Virgin Islands);
2. "BCC - BCR" birds are BCCs that are of concern only in particular Bird Conservation Regions (BCRs) in the continental USA; and
3. "Non-BCC - Vulnerable" birds are not BCC species in your project area, but appear on your list either because of the [Eagle Act](#) requirements (for eagles) or (for non-eagles) potential susceptibilities in offshore areas from certain types of development or activities (e.g. offshore energy development or longline fishing).

Although it is important to try to avoid and minimize impacts to all birds, efforts should be made, in particular, to avoid and minimize impacts to the birds on this list, especially eagles and BCC species of rangewide concern. For more information on conservation measures you can implement to help avoid and minimize migratory bird impacts and requirements for eagles, please see the FAQs for these topics.

Details about birds that are potentially affected by offshore projects

For additional details about the relative occurrence and abundance of both individual bird species and groups of bird species within your project area off the Atlantic Coast, please visit the [Northeast Ocean Data Portal](#). The Portal also offers data and information about other taxa besides birds that may be helpful to you in your project review. Alternately, you may download the bird model results files underlying the portal maps through the [NOAA NCCOS Integrative Statistical Modeling and Predictive Mapping of Marine Bird Distributions and Abundance on the Atlantic Outer Continental Shelf](#) project webpage.

Bird tracking data can also provide additional details about occurrence and habitat use throughout the year, including migration. Models relying on survey data may not include this information. For additional information on marine bird tracking data, see the [Diving Bird Study](#) and the [nanotag studies](#) or contact [Caleb Spiegel](#) or [Pam Loring](#).

What if I have eagles on my list?

If your project has the potential to disturb or kill eagles, you may need to [obtain a permit](#) to avoid violating the Eagle Act should such impacts occur.

Proper Interpretation and Use of Your Migratory Bird Report

The migratory bird list generated is not a list of all birds in your project area, only a subset of birds of priority concern. To learn more about how your list is generated, and see options for identifying what other birds may be in your project area, please see the FAQ "What does IPaC use to generate the migratory birds potentially occurring in my specified location". Please be aware this report provides the "probability of presence" of birds within the 10 km grid cell(s) that overlap your project; not your exact project footprint. On the graphs provided, please also look carefully at the survey effort (indicated by the black vertical bar) and for the existence of the "no data" indicator (a red horizontal bar). A high survey effort is the key component. If the survey effort is high, then the probability of presence score can be viewed as more dependable. In contrast, a low survey effort bar or no data bar means a lack of data and, therefore, a lack of certainty about presence of the species. This list is not perfect; it is simply a starting point for identifying what birds of concern have the potential to be in your project area, when they might be there, and if they might be breeding (which means nests might be present). The list helps you know what to look for to confirm presence, and helps guide you in knowing when to implement conservation measures to avoid or minimize potential impacts from your project activities, should presence be confirmed. To learn more about conservation measures, visit the FAQ "Tell me about conservation measures I can implement to avoid or minimize impacts to migratory birds" at the bottom of your migratory bird trust resources page.

Facilities

National Wildlife Refuge lands

Any activity proposed on lands managed by the [National Wildlife Refuge](#) system must undergo a 'Compatibility Determination' conducted by the Refuge. Please contact the individual Refuges to discuss any questions or concerns.

There are no refuge lands at this location.

Fish hatcheries

There are no fish hatcheries at this location.

Wetlands in the National Wetlands Inventory (NWI)

Impacts to [NWI wetlands](#) and other aquatic habitats may be subject to regulation under Section 404 of the Clean Water Act, or other State/Federal statutes.

For more information please contact the Regulatory Program of the local [U.S. Army Corps of Engineers District](#).

This location did not intersect any wetlands mapped by NWI.

NOTE: This initial screening does **not** replace an on-site delineation to determine whether wetlands occur. Additional information on the NWI data is provided below.

Data limitations

The Service's objective of mapping wetlands and deepwater habitats is to produce reconnaissance level information on the location, type and size of these resources. The maps are prepared from the analysis of high altitude imagery. Wetlands are identified based on vegetation, visible hydrology and geography. A margin of error is inherent in the use of imagery; thus, detailed on-the-ground inspection of any particular site may result in revision of the wetland boundaries or classification established through image analysis.

The accuracy of image interpretation depends on the quality of the imagery, the experience of the image analysts, the amount and quality of the collateral data and the amount of ground truth verification work conducted. Metadata should be consulted to determine the date of the source imagery used and any mapping problems.

Wetlands or other mapped features may have changed since the date of the imagery or field work. There may be occasional differences in polygon boundaries or classifications between the information depicted on the map and the actual conditions on site.

Data exclusions

Certain wetland habitats are excluded from the National mapping program because of the limitations of aerial imagery as the primary data source used to detect wetlands. These habitats include seagrasses or

submerged aquatic vegetation that are found in the intertidal and subtidal zones of estuaries and nearshore coastal waters. Some deepwater reef communities (coral or tubercid worm reefs) have also been excluded from the inventory. These habitats, because of their depth, go undetected by aerial imagery.

Data precautions

Federal, state, and local regulatory agencies with jurisdiction over wetlands may define and describe wetlands in a different manner than that used in this inventory. There is no attempt, in either the design or products of this inventory, to define the limits of proprietary jurisdiction of any Federal, state, or local government or to establish the geographical scope of the regulatory programs of government agencies. Persons intending to engage in activities involving modifications within or adjacent to wetland areas should seek the advice of appropriate Federal, state, or local agencies concerning specified agency regulatory programs and proprietary jurisdictions that may affect such activities.

NOT FOR CONSULTATION

ATTACHMENT 4
TPWD RARE SPECIES LIST

Last Update: 1/4/2023

BEXAR COUNTY

AMPHIBIANS

Cascade Caverns salamander *Eurycea latitans*

Aquatic; springs, streams and caves with rocky or cobble beds.

Federal Status:	State Status: T	SGCN: Y
Endemic: Y	Global Rank: G3	State Rank: S2

eastern tiger salamander *Ambystoma tigrinum*

Terrestrial adults generally occur under cover objects or in burrows surrounding a variety of lentic freshwater habitats, such as ponds, lakes, bottomland wetlands, or upland ephemeral pools. The specific terrestrial habitats are also varied and the occurrence of this species seems to be more closely associated with sandy, loamy or other soils which have easy burrowing properties, rather than any particular ecological system type. Requires fishless breeding pools for successful reproduction.

Federal Status:	State Status:	SGCN: Y
Endemic: N	Global Rank: G5	State Rank: S3

Strecker's chorus frog *Pseudacris streckeri*

Terrestrial and aquatic: Wooded floodplains and flats, prairies, cultivated fields and marshes. Likes sandy substrates.

Federal Status:	State Status:	SGCN: Y
Endemic: N	Global Rank: G5	State Rank: S3

Texas salamander *Eurycea neotenes*

Aquatic; springs, streams and caves with rocky or cobble beds.

Federal Status:	State Status: T	SGCN: Y
Endemic: Y	Global Rank: G1G2	State Rank: S1S2

Valdina Farms sinkhole salamander *Eurycea troglodytes*

Aquatic; springs, streams and caves with rocky or cobble beds.

Federal Status:	State Status:	SGCN: N
Endemic: Y	Global Rank: G3	State Rank: S3S4

Woodhouse's toad *Anaxyrus woodhousii*

Terrestrial and aquatic: A wide variety of terrestrial habitats are used by this species, including forests, grasslands, and barrier island sand dunes. Aquatic habitats are equally varied.

Federal Status:	State Status:	SGCN: Y
Endemic: N	Global Rank: G5	State Rank: SU

ARACHNIDS

Braken Bat Cave meshweaver *Cicurina venii*

Small, eyeless, or essentially eyeless spider; karst features in north and northwest Bexar County

Federal Status: LE	State Status:	SGCN: Y
--------------------	---------------	---------

DISCLAIMER

The information on this web application is provided "as is" without warranty as to the currentness, completeness, or accuracy of any specific data. The data provided are for planning, assessment, and informational purposes. Refer to the Frequently Asked Questions (FAQs) on the application website for further information.

BEXAR COUNTY

ARACHNIDS

Endemic: Y Global Rank: G1 State Rank: S1

Cokendolpher Cave harvestman *Texella cokendolpheri*

Small, eyeless harvestman; karst features in north and northwest Bexar County

Federal Status: LE State Status: SGCN: Y
Endemic: Y Global Rank: G1 State Rank: S1

Government Canyon Bat Cave meshweaver *Cicurina vespera*

Small, eyeless, or essentially eyeless spider; karst features in north and northwest Bexar County

Federal Status: LE State Status: SGCN: Y
Endemic: Y Global Rank: G1 State Rank: S1

Government Canyon Bat Cave spider *Neoleptoneta microps*

Small, eyeless, or essentially eyeless spider; karst features in north and northwest Bexar County

Federal Status: LE State Status: SGCN: Y
Endemic: Y Global Rank: G1 State Rank: S1

Madla Cave meshweaver *Cicurina madla*

Small, eyeless, or essentially eyeless spider; karst features in north and northwest Bexar County

Federal Status: LE State Status: SGCN: Y
Endemic: Y Global Rank: G1 State Rank: S1

No accepted common name *Tartarocreagris amblyopa*

Habitat description is not available at this time.

Federal Status: State Status: SGCN: Y
Endemic: Y Global Rank: G1G2 State Rank: S1

No accepted common name *Tartarocreagris reyesi*

Habitat description is not available at this time.

Federal Status: State Status: SGCN: Y
Endemic: Y Global Rank: GNR State Rank: S1

Reddell's Cave Millipede *Speodesmus reddelli*

Habitat description is not available at this time.

Federal Status: State Status: SGCN: Y
Endemic: Y Global Rank: GNR State Rank: S3

Robber Baron Cave meshweaver *Cicurina baronia*

DISCLAIMER

The information on this web application is provided "as is" without warranty as to the currentness, completeness, or accuracy of any specific data. The data provided are for planning, assessment, and informational purposes. Refer to the Frequently Asked Questions (FAQs) on the application website for further information.

BEXAR COUNTY

ARACHNIDS

Small, eyeless, or essentially eyeless spider; karst features in north and northwest Bexar County

Federal Status: LE	State Status:	SGCN: Y
Endemic: Y	Global Rank: G1	State Rank: S1

ARTHROPODS

Ivy's Cave Millipede *Speodesmus ivyi*

Habitat description is not available at this time.

Federal Status:	State Status:	SGCN: Y
Endemic: Y	Global Rank: GNR	State Rank: S2

Sickled Cave Millipede *Speodesmus falcatus*

Habitat description is not available at this time.

Federal Status:	State Status:	SGCN: Y
Endemic: Y	Global Rank: GNR	State Rank: S2

BIRDS

bald eagle *Haliaeetus leucocephalus*

Found primarily near rivers and large lakes; nests in tall trees or on cliffs near water; communally roosts, especially in winter; hunts live prey, scavenges, and pirates food from other birds

Federal Status:	State Status:	SGCN: Y
Endemic: N	Global Rank: G5	State Rank: S3B,S3N

black-capped vireo *Vireo atricapilla*

Oak-juniper woodlands with distinctive patchy, two-layered aspect; shrub and tree layer with open, grassy spaces; requires foliage reaching to ground level for nesting cover; return to same territory, or one nearby, year after year; deciduous and broad-leaved shrubs and trees provide insects for feeding; species composition less important than presence of adequate broad-leaved shrubs, foliage to ground level, and required structure; nesting season March-late summer

Federal Status:	State Status:	SGCN: Y
Endemic: N	Global Rank: G5	State Rank: S3B

chestnut-collared longspur *Calcarius ornatus*

Occurs in open shortgrass settings especially in patches with some bare ground. Also occurs in grain sorghum fields and Conservation Reserve Program lands

Federal Status:	State Status:	SGCN: Y
Endemic: N	Global Rank: G5	State Rank: S3

DISCLAIMER

The information on this web application is provided "as is" without warranty as to the currentness, completeness, or accuracy of any specific data. The data provided are for planning, assessment, and informational purposes. Refer to the Frequently Asked Questions (FAQs) on the application website for further information.

BEXAR COUNTY

BIRDS

Franklin's gull *Leucophaeus pipixcan*

The county distribution for this species includes geographic areas that the species may use during migration. Time of year should be factored into evaluations to determine potential presence of this species in a specific county. This species is only a spring and fall migrant throughout Texas. It does not breed in or near Texas. Winter records are unusual consisting of one or a few individuals at a given site (especially along the Gulf coastline). During migration, these gulls fly during daylight hours but often come down to wetlands, lake shore, or islands to roost for the night.

Federal Status:	State Status:	SGCN: Y
Endemic: N	Global Rank: G5	State Rank: S2N

golden-cheeked warbler *Setophaga chrysoparia*

Ashe juniper in mixed stands with various oaks (*Quercus* spp.). Edges of cedar brakes. Dependent on Ashe juniper (also known as cedar) for long fine bark strips, only available from mature trees, used in nest construction; nests are placed in various trees other than Ashe juniper; only a few mature junipers or nearby cedar brakes can provide the necessary nest material; forage for insects in broad-leaved trees and shrubs; nesting late March-early summer.

Federal Status: LE	State Status: E	SGCN: Y
Endemic: N	Global Rank: G2	State Rank: S2S3B

lark bunting *Calamospiza melanocorys*

Overall, it's a generalist in most short grassland settings including ones with some brushy component plus certain agricultural lands that include grain sorghum. Short grasses include sideoats and blue gramas, sand dropseed, prairie junegrass (*Koeleria*), buffalograss also with patches of bluestem and other mid-grass species. This bunting will frequent smaller patches of grasses or disturbed patches of grasses including rural yards. It also uses weedy fields surrounding playas. This species avoids urban areas and cotton fields.

Federal Status:	State Status:	SGCN: Y
Endemic: N	Global Rank: G5	State Rank: S4B

mountain plover *Charadrius montanus*

The county distribution for this species includes geographic areas that the species may use during migration. Time of year should be factored into evaluations to determine potential presence of this species in a specific county. Breeding: nests on high plains or shortgrass prairie, on ground in shallow depression; nonbreeding: shortgrass plains and bare, dirt (plowed) fields; primarily insectivorous.

Federal Status:	State Status:	SGCN: Y
Endemic: N	Global Rank: G3	State Rank: S2

DISCLAIMER

The information on this web application is provided "as is" without warranty as to the currentness, completeness, or accuracy of any specific data. The data provided are for planning, assessment, and informational purposes. Refer to the Frequently Asked Questions (FAQs) on the application website for further information.

BEXAR COUNTY

BIRDS

piping plover *Charadrius melodus*

The county distribution for this species includes geographic areas that the species may use during migration. Time of year should be factored into evaluations to determine potential presence of this species in a specific county. Beaches, sandflats, and dunes along Gulf Coast beaches and adjacent offshore islands. Also spoil islands in the Intracoastal Waterway. Based on the November 30, 1992 Section 6 Job No. 9.1, Piping Plover and Snowy Plover Winter Habitat Status Survey, algal flats appear to be the highest quality habitat. Some of the most important aspects of algal flats are their relative inaccessibility and their continuous availability throughout all tidal conditions. Sand flats often appear to be preferred over algal flats when both are available, but large portions of sand flats along the Texas coast are available only during low-very low tides and are often completely unavailable during extreme high tides or strong north winds. Beaches appear to serve as a secondary habitat to the flats associated with the primary bays, lagoons, and inter-island passes. Beaches are rarely used on the southern Texas coast, where bayside habitat is always available, and are abandoned as bayside habitats become available on the central and northern coast. However, beaches are probably a vital habitat along the central and northern coast (i.e. north of Padre Island) during periods of extreme high tides that cover the flats. Optimal site characteristics appear to be large in area, sparsely vegetated, continuously available or in close proximity to secondary habitat, and with limited human disturbance.

Federal Status: LT	State Status: T	SGCN: Y
Endemic: N	Global Rank: G3	State Rank: S2N

Sprague's pipit *Anthus spragueii*

The county distribution for this species includes geographic areas that the species may use during migration. Time of year should be factored into evaluations to determine potential presence of this species in a specific county. Habitat during migration and in winter consists of pastures and weedy fields (AOU 1983), including grasslands with dense herbaceous vegetation or grassy agricultural fields.

Federal Status:	State Status:	SGCN: Y
Endemic: N	Global Rank: G3G4	State Rank: S3N

western burrowing owl *Athene cunicularia hypugaea*

Open grasslands, especially prairie, plains, and savanna, sometimes in open areas such as vacant lots near human habitation or airports; nests and roosts in abandoned burrows

Federal Status:	State Status:	SGCN: Y
Endemic: N	Global Rank: G4T4	State Rank: S2

white-faced ibis *Plegadis chihi*

The county distribution for this species includes geographic areas that the species may use during migration. Time of year should be factored into evaluations to determine potential presence of this species in a specific county. Prefers freshwater marshes, sloughs, and irrigated rice fields, but will attend brackish and saltwater habitats; currently confined to near-coastal rookeries in so-called hog-wallow prairies. Nests in marshes, in low trees, on the ground in bulrushes or reeds, or on floating mats.

Federal Status:	State Status: T	SGCN: Y
Endemic: N	Global Rank: G5	State Rank: S4B

whooping crane *Grus americana*

The county distribution for this species includes geographic areas that the species may use during migration. Time of year should be factored into evaluations to determine potential presence of this species in a specific county. Small ponds, marshes, and flooded grain fields for both roosting and foraging. Potential migrant via plains throughout most of state to coast; winters in coastal marshes of Aransas, Calhoun, and Refugio counties.

Federal Status: LE	State Status: E	SGCN: Y
Endemic: N	Global Rank: G1	State Rank: S1S2N

DISCLAIMER

The information on this web application is provided "as is" without warranty as to the currentness, completeness, or accuracy of any specific data. The data provided are for planning, assessment, and informational purposes. Refer to the Frequently Asked Questions (FAQs) on the application website for further information.

BEXAR COUNTY

BIRDS

wood stork *Mycteria americana*

The county distribution for this species includes geographic areas that the species may use during migration. Time of year should be factored into evaluations to determine potential presence of this species in a specific county. Prefers to nest in large tracts of baldcypress (*Taxodium distichum*) or red mangrove (*Rhizophora mangle*); forages in prairie ponds, flooded pastures or fields, ditches, and other shallow standing water, including salt-water; usually roosts communally in tall snags, sometimes in association with other wading birds (i.e. active heronries); breeds in Mexico and birds move into Gulf States in search of mud flats and other wetlands, even those associated with forested areas; formerly nested in Texas, but no breeding records since 1960.

Federal Status:	State Status: T	SGCN: Y
Endemic: N	Global Rank: G4	State Rank: SHB,S2N

CRUSTACEANS

Cascade Cave amphipod *Stygobromus dejectus*

Subaquatic crustacean; subterranean obligate; in pools

Federal Status:	State Status:	SGCN: Y
Endemic: Y	Global Rank: G1G2	State Rank: S1

Ezell's Cave amphipod *Stygobromus flagellatus*

Known only from artesian wells

Federal Status:	State Status:	SGCN: Y
Endemic: Y	Global Rank: G2G3	State Rank: S3

No accepted common name *Mexiweckelia hardeni*

Habitat description is not available at this time.

Federal Status:	State Status:	SGCN: Y
Endemic: Y	Global Rank: G2G3	State Rank: S2

No accepted common name *Speocirolana hardeni*

Habitat description is not available at this time.

Federal Status:	State Status:	SGCN: Y
Endemic: N	Global Rank: G2G3	State Rank: S2

DISCLAIMER

The information on this web application is provided "as is" without warranty as to the currentness, completeness, or accuracy of any specific data. The data provided are for planning, assessment, and informational purposes. Refer to the Frequently Asked Questions (FAQs) on the application website for further information.

BEXAR COUNTY

FISH

Guadalupe bass *Micropterus treculii*

Endemic to the streams of the northern and eastern Edwards Plateau including portions of the Brazos, Colorado, Guadalupe, and San Antonio basins; species also found outside of the Edwards Plateau streams in decreased abundance, primarily in the lower Colorado River; two introduced populations have been established in the Nueces River system. A pure population was re-established in a portion of the Blanco River in 2014. Species prefers lentic environments but commonly taken in flowing water; numerous smaller fish occur in rapids, many times near eddies; large individuals found mainly in riffle tail races; usually found in spring-fed streams having clear water and relatively consistent temperatures.

Federal Status: State Status: SGCN: Y
Endemic: Y Global Rank: G3 State Rank: S3

river darter *Percina shumardi*

In Texas limited to eastern streams including Red River southward to the Neches River, and a disjunct population in the Guadalupe and San Antonio river systems east of the Balcones Escarpment. Confined to large rivers and lower parts of major tributaries; usually found in deep chutes and riffles where current is swift and bottom composed of coarse gravel or rock.

Federal Status: State Status: SGCN: Y
Endemic: Global Rank: G5 State Rank: S4

Texas shiner *Notropis amabilis*

In Texas, it is found primarily in Edwards Plateau streams from the San Gabriel River in the east to the Pecos River in the west. Typical habitat includes rocky or sandy runs, as well as pools.

Federal Status: State Status: SGCN: Y
Endemic: N Global Rank: G4 State Rank: S4

toothless blindcat *Trogloglanis pattersoni*

Restricted to five artesian wells penetrating the San Antonio Pool of the Edwards Aquifer; found at depths of 305-582 m.

Federal Status: State Status: T SGCN: Y
Endemic: Y Global Rank: G1G2 State Rank: S1

widemouth blindcat *Satan eurystomus*

Restricted to five artesian wells penetrating the San Antonio Pool of the Edwards Aquifer; found at depths of 305-582 m.

Federal Status: State Status: T SGCN: Y
Endemic: Y Global Rank: G1G2 State Rank: S1

INSECTS

American bumblebee *Bombus pensylvanicus*

Habitat description is not available at this time.

Federal Status: State Status: SGCN: Y
Endemic: Global Rank: G3G4 State Rank: SNR

DISCLAIMER

The information on this web application is provided "as is" without warranty as to the currentness, completeness, or accuracy of any specific data. The data provided are for planning, assessment, and informational purposes. Refer to the Frequently Asked Questions (FAQs) on the application website for further information.

BEXAR COUNTY

INSECTS

Helotes mold beetle

Batrisodes venyivi

Small, eyeless mold beetle; karst features in northwestern Bexar County and northeastern Medina County

Federal Status: LE

State Status:

SGCN: Y

Endemic: Y

Global Rank: G1

State Rank: S1

Manfreda giant-skipper

Stallingsia maculosus

Most skippers are small and stout-bodied; name derives from fast, erratic flight; at rest most skippers hold front and hind wings at different angles; skipper larvae are smooth, with the head and neck constricted; skipper larvae usually feed inside a leaf shelter and pupate in a cocoon made of leaves fastened together with silk

Federal Status:

State Status:

SGCN: Y

Endemic: N

Global Rank: G1

State Rank: S1

No accepted common name

Pygarctia lorula

Habitat description is not available at this time.

Federal Status:

State Status:

SGCN: Y

Endemic: Y

Global Rank: G2G3

State Rank: S2?

No accepted common name

Dichopetala catinata

Habitat description is not available at this time.

Federal Status:

State Status:

SGCN: Y

Endemic:

Global Rank: GNR

State Rank: SNR

No accepted common name

Dichopetala seeversi

Habitat description is not available at this time.

Federal Status:

State Status:

SGCN: Y

Endemic:

Global Rank: GNR

State Rank: SNR

No accepted common name

Nectopsyche texana

Riparian, Riverine

Federal Status:

State Status:

SGCN: Y

Endemic:

Global Rank: G1G3

State Rank: S2?

No accepted common name

Batrisodes shadeae

This species was recently described from a single cave in Bexar Co., Texas (Chandler et al., 2009).

Federal Status:

State Status:

SGCN: Y

Endemic:

Global Rank: G1

State Rank: SNR

No accepted common name

Lymantes nadineae

Habitat description is not available at this time.

Federal Status:

State Status:

SGCN: Y

DISCLAIMER

The information on this web application is provided "as is" without warranty as to the currentness, completeness, or accuracy of any specific data. The data provided are for planning, assessment, and informational purposes. Refer to the Frequently Asked Questions (FAQs) on the application website for further information.

BEXAR COUNTY

INSECTS

Endemic: Y	Global Rank: GNR	State Rank: S2
No accepted common name	<i>Cotalpa conclamara</i>	
Habitat description is not available at this time.		
Federal Status:	State Status:	SGCN: Y
Endemic:	Global Rank: GNR	State Rank: SNR
No accepted common name	<i>Cotinis boylei</i>	
Habitat description is not available at this time.		
Federal Status:	State Status:	SGCN: Y
Endemic:	Global Rank: GNR	State Rank: SNR
No accepted common name	<i>Rhadine exilis</i>	
Small, essentially eyeless ground beetle; karst features in north and northwest Bexar County		
Federal Status: LE	State Status:	SGCN: Y
Endemic: Y	Global Rank: G3	State Rank: S1
No accepted common name	<i>Rhadine infernalis</i>	
Small, essentially eyeless ground beetle; karst features in north and northwest Bexar County		
Federal Status: LE	State Status:	SGCN: Y
Endemic: Y	Global Rank: G2G3	State Rank: S1
No accepted common name	<i>Rhadine bullis</i>	
Habitat description is not available at this time.		
Federal Status:	State Status:	SGCN: Y
Endemic:	Global Rank: GNR	State Rank: SNR
No accepted common name	<i>Bombus variabilis</i>	
Habitat description is not available at this time.		
Federal Status:	State Status:	SGCN: Y
Endemic:	Global Rank: G1G2	State Rank: SNR
No accepted common name	<i>Megachile parksi</i>	
Habitat description is not available at this time.		
Federal Status:	State Status:	SGCN: Y
Endemic:	Global Rank: GH	State Rank: SNR

MAMMALS

big brown bat *Eptesicus fuscus*

DISCLAIMER

The information on this web application is provided "as is" without warranty as to the currentness, completeness, or accuracy of any specific data. The data provided are for planning, assessment, and informational purposes. Refer to the Frequently Asked Questions (FAQs) on the application website for further information.

BEXAR COUNTY

MAMMALS

Any wooded areas or woodlands except south Texas. Riparian areas in west Texas.

Federal Status:	State Status:	SGCN: Y
Endemic: N	Global Rank: G5	State Rank: S5

big free-tailed bat *Nyctinomops macrotis*

Habitat data sparse but records indicate that species prefers to roost in crevices and cracks in high canyon walls, but will use buildings, as well; reproduction data sparse, gives birth to single offspring late June-early July; females gather in nursery colonies; winter habits undetermined, but may hibernate in the Trans-Pecos; opportunistic insectivore

Federal Status:	State Status:	SGCN: Y
Endemic: N	Global Rank: G5	State Rank: S3

black bear *Ursus americanus*

Generalist. Historically found throughout Texas. In Chisos, prefers higher elevations where pinyon-oaks predominate; also occasionally sighted in desert scrub of Trans-Pecos (Black Gap Wildlife Management Area) and Edwards Plateau in juniper-oak habitat. For ssp. *luteolus*, bottomland hardwoods, floodplain forests, upland hardwoods with mixed pine; marsh. Bottomland hardwoods and large tracts of inaccessible forested areas.

Federal Status:	State Status: T	SGCN: Y
Endemic: N	Global Rank: G5	State Rank: S3

black-tailed prairie dog *Cynomys ludovicianus*

Dry, flat, short grasslands with low, relatively sparse vegetation, including areas overgrazed by cattle; live in large family groups

Federal Status:	State Status:	SGCN: Y
Endemic: N	Global Rank: G4	State Rank: S3

cave myotis bat *Myotis velifer*

Colonial and cave-dwelling; also roosts in rock crevices, old buildings, carports, under bridges, and even in abandoned Cliff Swallow (*Hirundo pyrrhonota*) nests; roosts in clusters of up to thousands of individuals; hibernates in limestone caves of Edwards Plateau and gypsum cave of Panhandle during winter; opportunistic insectivore.

Federal Status:	State Status:	SGCN: Y
Endemic: N	Global Rank: G4G5	State Rank: S2S3

eastern red bat *Lasiurus borealis*

Red bats are migratory bats that are common across Texas. They are most common in the eastern and central parts of the state, due to their requirement of forests for foliage roosting. West Texas specimens are associated with forested areas (cottonwoods). Also common along the coastline. These bats are highly mobile, seasonally migratory, and practice a type of "wandering migration". Associations with specific habitat is difficult unless specific migratory stopover sites or wintering grounds are found. Likely associated with any forested area in East, Central, and North Texas but can occur statewide.

Federal Status:	State Status:	SGCN: Y
Endemic: N	Global Rank: G3G4	State Rank: S4

DISCLAIMER

The information on this web application is provided "as is" without warranty as to the currentness, completeness, or accuracy of any specific data. The data provided are for planning, assessment, and informational purposes. Refer to the Frequently Asked Questions (FAQs) on the application website for further information.

BEXAR COUNTY

MAMMALS

eastern spotted skunk

Spilogale putorius

Generalist; open fields prairies, croplands, fence rows, farmyards, forest edges & woodlands. Prefer wooded, brushy areas & tallgrass prairies. S.p. ssp. interrupta found in wooded areas and tallgrass prairies, preferring rocky canyons and outcrops when such sites are available.

Federal Status:

State Status:

SGCN: Y

Endemic: N

Global Rank: G4

State Rank: S1S3

hoary bat

Lasiurus cinereus

Hoary bats are highly migratory, high-flying bats that have been noted throughout the state. Females are known to migrate to Mexico in the winter, males tend to remain further north and may stay in Texas year-round. Commonly associated with forests (foliage roosting species) but are found in unforested parts of the state and lowland deserts. Tend to be captured over water and large, open flyways.

Federal Status:

State Status:

SGCN: Y

Endemic: N

Global Rank: G3G4

State Rank: S4

long-tailed weasel

Mustela frenata

Includes brushlands, fence rows, upland woods and bottomland hardwoods, forest edges & rocky desert scrub. Usually live close to water.

Federal Status:

State Status:

SGCN: Y

Endemic: N

Global Rank: G5

State Rank: S5

mountain lion

Puma concolor

Generalist; found in a wide range of habitats statewide. Found most frequently in rugged mountains & riparian zones.

Federal Status:

State Status:

SGCN: Y

Endemic: N

Global Rank: G5

State Rank: S2S3

northern yellow bat

Lasiurus intermedius

Occurs mainly along the Gulf Coast but inland specimens are not uncommon. Prefers roosting in spanish moss and in the hanging fronds of palm trees. Common where this vegetation occurs. Found near water and forages over grassy, open areas. Males usually roost solitarily, whereas females roost in groups of several individuals.

Federal Status:

State Status:

SGCN: Y

Endemic: N

Global Rank: G5

State Rank: S4

swamp rabbit

Sylvilagus aquaticus

Primarily found in lowland areas near water including: cypress bogs and marshes, floodplains, creeks and rivers.

Federal Status:

State Status:

SGCN: Y

Endemic: N

Global Rank: G5

State Rank: S5

tricolored bat

Perimyotis subflavus

Forest, woodland and riparian areas are important. Caves are very important to this species.

Federal Status:

State Status:

SGCN: Y

Endemic: N

Global Rank: G3G4

State Rank: S2

DISCLAIMER

The information on this web application is provided "as is" without warranty as to the currentness, completeness, or accuracy of any specific data. The data provided are for planning, assessment, and informational purposes. Refer to the Frequently Asked Questions (FAQs) on the application website for further information.

BEXAR COUNTY

MAMMALS

western hog-nosed skunk *Conepatus leuconotus*

Habitats include woodlands, grasslands & deserts, to 7200 feet, most common in rugged, rocky canyon country; little is known about the habitat of the ssp. *telmalestes*

Federal Status: State Status: SGCN: Y
Endemic: N Global Rank: G4 State Rank: S4

western spotted skunk *Spilogale gracilis*

Brushy canyons, rocky outcrops (rimrock) on hillsides and walls of canyons. In semi-arid brushlands in U.S., in wet tropical forests in Mexico. When inactive or bearing young, occupies den in rocks, burrow, hollow log, brush pile, or under building.

Federal Status: State Status: SGCN: Y
Endemic: N Global Rank: G5 State Rank: S5

white-nosed coati *Nasua narica*

Woodlands, riparian corridors and canyons. Most individuals in Texas probably transients from Mexico; diurnal and crepuscular; very sociable; forages on ground and in trees; omnivorous; may be susceptible to hunting, trapping, and pet trade

Federal Status: State Status: T SGCN: Y
Endemic: N Global Rank: G5 State Rank: S1

MOLLUSKS

false spike *Fusconaia mitchelli*

Occurs in small streams to medium-size rivers in habitats such as riffles and runs with flowing water. Is often found in stable substrates of sand, gravel, and cobble (Howells 2010; Randklev et al. 2012; Sowards et al. 2013; Tsakiris and Randklev 2016). [Mussels of Texas 2019]

Federal Status: PE State Status: T SGCN: Y
Endemic: N Global Rank: GNR State Rank: S1

mimic cavesnail *Phreatodrobia imitata*

Subaquatic; only known from two wells penetrating the Edwards Aquifer

Federal Status: State Status: SGCN: Y
Endemic: Y Global Rank: G1 State Rank: S1

No accepted common name *Phreatodrobia conica*

Habitat description is not available at this time.

Federal Status: State Status: SGCN: Y
Endemic: Y Global Rank: G1 State Rank: S2

DISCLAIMER

The information on this web application is provided "as is" without warranty as to the currentness, completeness, or accuracy of any specific data. The data provided are for planning, assessment, and informational purposes. Refer to the Frequently Asked Questions (FAQs) on the application website for further information.

BEXAR COUNTY

REPTILES

Cagle's map turtle *Graptemys caglei*

Aquatic: shallow water with swift to moderate flow and gravel or cobble bottom, connected by deeper pools with a slower flow rate and a silt or mud bottom; gravel bar riffles and transition areas between riffles and pools especially important in providing insect prey items; nests on gently sloping sand banks within ca. 30 feet of waters edge.

Federal Status: State Status: T SGCN: Y
Endemic: Y Global Rank: G3 State Rank: S1

eastern box turtle *Terrapene carolina*

Terrestrial: Eastern box turtles inhabit forests, fields, forest-brush, and forest-field ecotones. In some areas they move seasonally from fields in spring to forest in summer. They commonly enters pools of shallow water in summer. For shelter, they burrow into loose soil, debris, mud, old stump holes, or under leaf litter. They can successfully hibernate in sites that may experience subfreezing temperatures.

Federal Status: State Status: SGCN: Y
Endemic: N Global Rank: G5 State Rank: S3

plateau spot-tailed earless lizard *Holbrookia lacerata*

Terrestrial: Habitats include moderately open prairie-brushland regions, particularly fairly flat areas free of vegetation or other obstructions (e.g., open meadows, old and new fields, graded roadways, cleared and disturbed areas, prairie savanna, and active agriculture including row crops); also, oak-juniper woodlands and mesquite-prickly pear associations (Axtell 1968, Bartlett and Bartlett 1999).

Federal Status: State Status: SGCN: Y
Endemic: Y Global Rank: GNR State Rank: S2

prairie skink *Plestiodon septentrionalis*

The prairie skink can occur in any native grassland habitat across the Rolling Plains, Blackland Prairie, Post Oak Savanna and Pineywoods ecoregions.

Federal Status: State Status: SGCN: Y
Endemic: N Global Rank: G5 State Rank: S2

slender glass lizard *Ophisaurus attenuatus*

Terrestrial: Habitats include open grassland, prairie, woodland edge, open woodland, oak savannas, longleaf pine flatwoods, scrubby areas, fallow fields, and areas near streams and ponds, often in habitats with sandy soil.

Federal Status: State Status: SGCN: Y
Endemic: N Global Rank: G5 State Rank: S3

Tamaulipan spot-tailed earless lizard *Holbrookia subcaudalis*

Terrestrial: Habitats include moderately open prairie-brushland regions, particularly fairly flat areas free of vegetation or other obstructions (e.g., open meadows, old and new fields, graded roadways, cleared and disturbed areas, prairie savanna, and active agriculture including row crops); also, oak-juniper woodlands and mesquite-prickly pear associations (Axtell 1968, Bartlett and Bartlett 1999).

Federal Status: State Status: SGCN: Y
Endemic: N Global Rank: GNR State Rank: S2

Texas garter snake *Thamnophis sirtalis annectens*

DISCLAIMER

The information on this web application is provided "as is" without warranty as to the currentness, completeness, or accuracy of any specific data. The data provided are for planning, assessment, and informational purposes. Refer to the Frequently Asked Questions (FAQs) on the application website for further information.

BEXAR COUNTY

REPTILES

Terrestrial and aquatic: Habitats used include the grasslands and modified open areas in the vicinity of aquatic features, such as ponds, streams or marshes. Damp soils and debris for cover are thought to be critical.

Federal Status:	State Status:	SGCN: Y
Endemic: Y	Global Rank: G5T4	State Rank: S1

Texas horned lizard *Phrynosoma cornutum*

Terrestrial: Open habitats with sparse vegetation, including grass, prairie, cactus, scattered brush or scrubby trees; soil may vary in texture from sandy to rocky; burrows into soil, enters rodent burrows, or hides under rock when inactive. Occurs to 6000 feet, but largely limited below the pinyon-juniper zone on mountains in the Big Bend area.

Federal Status:	State Status: T	SGCN: Y
Endemic: N	Global Rank: G4G5	State Rank: S3

Texas indigo snake *Drymarchon melanurus erebennus*

Terrestrial: Thornbush-chaparral woodland of south Texas, in particular dense riparian corridors. Can do well in suburban and irrigated croplands. Requires moist microhabitats, such as rodent burrows, for shelter.

Federal Status:	State Status:	SGCN: Y
Endemic: N	Global Rank: G5T4	State Rank: S4

Texas tortoise *Gopherus berlandieri*

Terrestrial: Open scrub woods, arid brush, lomas, grass-cactus association; often in areas with sandy well-drained soils. When inactive occupies shallow depressions dug at base of bush or cactus; sometimes in underground burrow or under object. Eggs are laid in nests dug in soil near or under bushes.

Federal Status:	State Status: T	SGCN: Y
Endemic: N	Global Rank: G4	State Rank: S2

timber (canebrake) rattlesnake *Crotalus horridus*

Terrestrial: Swamps, floodplains, upland pine and deciduous woodland, riparian zones, abandoned farmland. Limestone bluffs, sandy soil or black clay. Prefers dense ground cover, i.e. grapevines, palmetto.

Federal Status:	State Status:	SGCN: Y
Endemic: N	Global Rank: G4	State Rank: S4

western box turtle *Terrapene ornata*

Terrestrial: Ornate or western box turtles inhabit prairie grassland, pasture, fields, sandhills, and open woodland. They are essentially terrestrial but sometimes enter slow, shallow streams and creek pools. For shelter, they burrow into soil (e.g., under plants such as yucca) (Converse et al. 2002) or enter burrows made by other species.

Federal Status:	State Status:	SGCN: Y
Endemic: N	Global Rank: G5	State Rank: S3

DISCLAIMER

The information on this web application is provided "as is" without warranty as to the currentness, completeness, or accuracy of any specific data. The data provided are for planning, assessment, and informational purposes. Refer to the Frequently Asked Questions (FAQs) on the application website for further information.

BEXAR COUNTY

REPTILES

western hognose snake *Heterodon nasicus*

Terrestrial: Shortgrass or mixed grass prairie, with gravel or sandy soils. Often found associated with draws, floodplains, and more mesic habitats within the arid landscape. Frequently occurs in shrub encroached grasslands.

Federal Status: State Status: SGCN: Y
Endemic: N Global Rank: G5 State Rank: S4

western rattlesnake *Crotalus viridis*

Terrestrial: Dry desert and prairie grasslands, shrub desert rocky hillsides; edges of arid and semi-arid river breaks.

Federal Status: State Status: SGCN: Y
Endemic: N Global Rank: G5 State Rank: S5

PLANTS

awnless lestdaisy *Chaetopappa imberbis*

In woodlands on lomas of Carrizo sand (TEX-LL specimens Carr 23875, 12507). Flowering and fruiting during Mar - May.

Federal Status: State Status: SGCN: Y
Endemic: Y Global Rank: G3 State Rank: S3

big red sage *Salvia pentstemonoides*

Moist to seasonally wet, steep limestone outcrops on seeps within canyons or along creek banks; occasionally on clayey to silty soils of creek banks and terraces, in partial shade to full sun; basal leaves conspicuous for much of the year; flowering June-October

Federal Status: State Status: SGCN: Y
Endemic: Y Global Rank: G1 State Rank: S1

bigflower cornsalad *Valerianella stenocarpa*

Usually along creekbeds or in vernal moist grassy open areas (Carr 2015).

Federal Status: State Status: SGCN: Y
Endemic: Y Global Rank: G3 State Rank: S3

bracted twistflower *Streptanthus bracteatus*

Shallow, well-drained gravelly clays and clay loams over limestone in oak juniper woodlands and associated openings, on steep to moderate slopes and in canyon bottoms; several known soils include Tarrant, Brackett, or Speck over Edwards, Glen Rose, and Walnut geologic formations; populations fluctuate widely from year to year, depending on winter rainfall; flowering mid April-late May, fruit matures and foliage withers by early summer

Federal Status: PT State Status: SGCN: Y
Endemic: Y Global Rank: G1 State Rank: S1

DISCLAIMER

The information on this web application is provided "as is" without warranty as to the currentness, completeness, or accuracy of any specific data. The data provided are for planning, assessment, and informational purposes. Refer to the Frequently Asked Questions (FAQs) on the application website for further information.

BEXAR COUNTY

PLANTS

bristle nailwort

Paronychia setacea

Flowering vascular plant endemic to eastern southcentral Texas, occurring in sandy soils

Federal Status:	State Status:	SGCN: Y
Endemic: Y	Global Rank: G3	State Rank: S2

Buckley tridens

Tridens buckleyanus

Occurs in juniper-oak woodlands on rocky limestone slopes; Perennial; Flowering/Fruiting April-Nov

Federal Status:	State Status:	SGCN: Y
Endemic: Y	Global Rank: G3G4	State Rank: S3S4

Burridge greenthread

Thelesperma burridgeanum

Sandy open areas; Annual; Flowering March-Nov; Fruiting March-June

Federal Status:	State Status:	SGCN: Y
Endemic: Y	Global Rank: G3	State Rank: S3

Correll's false dragon-head

Physostegia correllii

Wet, silty clay loams on streamsides, in creek beds, irrigation channels and roadside drainage ditches; or seepy, mucky, sometimes gravelly soils along riverbanks or small islands in the Rio Grande; or underlain by Austin Chalk limestone along gently flowing spring-fed creek in central Texas; flowering May-September

Federal Status:	State Status:	SGCN: Y
Endemic: N	Global Rank: G2	State Rank: S2

Elmendorf's onion

Allium elmendorffii

Grassland openings in oak woodlands on deep, loose, well-drained sands; in Coastal Bend, on Pleistocene barrier island ridges and Holocene Sand Sheet that support live oak woodlands; to the north it occurs in post oak-black hickory-live oak woodlands over Queen City and similar Eocene formations; one anomalous specimen found on Llano Uplift in wet pockets of granitic loam; Perennial; Flowering March-April, May

Federal Status:	State Status:	SGCN: Y
Endemic: Y	Global Rank: G2	State Rank: S2

Glass Mountains coral-root

Hexalectris nitida

Apparently rare in mixed woodlands in canyons in the mountains of the Brewster County, but encountered with regularity, albeit in small numbers, under *Juniperus ashei* in woodlands over limestone on the Edwards Plateau, Callahan Divide and Lampasas Cutplain; Perennial; Flowering June-Sept; Fruiting July-Sept

Federal Status:	State Status:	SGCN: Y
Endemic: N	Global Rank: G3	State Rank: S3

gravelbar brickellbush

Brickellia dentata

Essentially restricted to frequently-scoured gravelly alluvial beds in creek and river bottoms; Perennial; Flowering June-Nov; Fruiting June-Oct

Federal Status:	State Status:	SGCN: Y
Endemic: Y	Global Rank: G3G4	State Rank: S3S4

DISCLAIMER

The information on this web application is provided "as is" without warranty as to the currentness, completeness, or accuracy of any specific data. The data provided are for planning, assessment, and informational purposes. Refer to the Frequently Asked Questions (FAQs) on the application website for further information.

BEXAR COUNTY

PLANTS

hairy sycamore-leaf snowbell *Styrax platanifolius ssp. stellatus*

Rare throughout range, in habitats similar to those of var. *platanifolius* - usually in oak-juniper woodlands on steep rocky banks and ledges along intermittent or perennial streams, rarely far from some reliable source of moisture; Perennial; Flowering April-Oct; Fruiting May-Sept

Federal Status: State Status: SGCN: Y
Endemic: Y Global Rank: G3T3 State Rank: S3

Heller's marbleseed *Onosmodium helleri*

Occurs in loamy calcareous soils in oak-juniper woodlands on rocky limestone slopes, often in more mesic portions of canyons; Perennial; Flowering March-May

Federal Status: State Status: SGCN: Y
Endemic: Y Global Rank: G3 State Rank: S3

Hill Country wild-mercury *Argythamnia aphoroides*

Mostly in bluestem-grama grasslands associated with plateau live oak woodlands on shallow to moderately deep clays and clay loams over limestone on rolling uplands, also in partial shade of oak-juniper woodlands in gravelly soils on rocky limestone slopes; Perennial; Flowering April-May with fruit persisting until midsummer

Federal Status: State Status: SGCN: Y
Endemic: Y Global Rank: G2G3 State Rank: S3

low spurge *Euphorbia peplidion*

Occurs in a variety of vernal-moist situations in a number of natural regions; Annual; Flowering Feb-April; Fruiting March-April

Federal Status: State Status: SGCN: Y
Endemic: Y Global Rank: G3 State Rank: S3

narrowleaf brickellbush *Brickellia eupatorioides var. gracillima*

Moist to dry gravelly alluvial soils along riverbanks but also on limestone slopes; Perennial; Flowering/Fruiting April-Nov

Federal Status: State Status: SGCN: Y
Endemic: Y Global Rank: G5T3 State Rank: S3

net-leaf bundleflower *Desmanthus reticulatus*

Mostly on clay prairies of the coastal plain of central and south Texas; Perennial; Flowering April-July; Fruiting April-Oct

Federal Status: State Status: SGCN: Y
Endemic: Y Global Rank: G3 State Rank: S3

Osage Plains false foxglove *Agalinis densiflora*

Most records are from grasslands on shallow, gravelly, well drained, calcareous soils; Prairies, dry limestone soils; Annual; Flowering Aug-Oct

Federal Status: State Status: SGCN: Y
Endemic: N Global Rank: G3 State Rank: S2

Parks' jointweed *Polygonella parksii*

DISCLAIMER

The information on this web application is provided "as is" without warranty as to the currentness, completeness, or accuracy of any specific data. The data provided are for planning, assessment, and informational purposes. Refer to the Frequently Asked Questions (FAQs) on the application website for further information.

BEXAR COUNTY

PLANTS

Mostly found on deep, loose, whitish sand blowouts (unstable, deep, xeric, sandhill barrens) in Post Oak Savanna landscapes over the Carrizo and Sparta formations; also occurs in early successional grasslands, along right-of-ways, and on mechanically disturbed areas; flowering June-late October or September-November

Federal Status: State Status: SGCN: Y
Endemic: Y Global Rank: G2 State Rank: S2

Plateau loosestrife *Lythrum ovalifolium*

Banks and gravelly beds of perennial (or strong intermittent) streams on the Edwards Plateau, Llano Uplift and Lampasas Cutplain; Perennial; Flowering/Fruiting April-Nov

Federal Status: State Status: SGCN: Y
Endemic: N Global Rank: G3G4 State Rank: S3S4

plateau milkvine *Matelea edwardsensis*

Occurs in various types of juniper-oak and oak-juniper woodlands; Perennial; Flowering March-Oct; Fruiting May-June

Federal Status: State Status: SGCN: Y
Endemic: Y Global Rank: G3 State Rank: S3

sandhill woollywhite *Hymenopappus carrizoanus*

Disturbed or open areas in grasslands and post oak woodlands on deep sands derived from the Carrizo Sand and similar Eocene formations; flowering April-June

Federal Status: State Status: SGCN: Y
Endemic: Y Global Rank: G2 State Rank: S2

Siler's huaco *Manfreda sileri*

Rare in a variety of grasslands and shrublands on dry sites; Perennial; Flowering April-July; Fruiting June-July

Federal Status: State Status: SGCN: Y
Endemic: N Global Rank: G3 State Rank: S3

South Texas rushpea *Caesalpinia phyllanthoides*

Tamaulipan thorn shrublands or grasslands on very shallow sandy to clayey soils over calcareous sandstone and caliche; flowering in spring, sometimes later in growing season, perhaps in response to rainfall

Federal Status: State Status: SGCN: Y
Endemic: N Global Rank: G2? State Rank: S1

sycamore-leaf snowbell *Styrax platanifolius ssp. platanifolius*

Rare throughout range, usually in oak-juniper woodlands on steep rocky banks and ledges along intermittent or perennial streams, rarely far from some reliable source of moisture; Perennial; Flowering April-May; Fruiting May-Aug.

Federal Status: State Status: SGCN: Y
Endemic: Y Global Rank: G3T3 State Rank: S3

Texas almond *Prunus minutiflora*

DISCLAIMER

The information on this web application is provided "as is" without warranty as to the currentness, completeness, or accuracy of any specific data. The data provided are for planning, assessment, and informational purposes. Refer to the Frequently Asked Questions (FAQs) on the application website for further information.

BEXAR COUNTY

PLANTS

Wide-ranging but scarce, in a variety of grassland and shrubland situations, mostly on calcareous soils underlain by limestone but occasionally in sandier neutral soils underlain by granite; Perennial; Flowering Feb-May and Oct; Fruiting Feb-Sept

Federal Status: State Status: SGCN: Y
Endemic: Y Global Rank: G3G4 State Rank: S3S4

Texas amorpha *Amorpha roemeriana*

Juniper-oak woodlands or shrublands on rocky limestone slopes, sometimes on dry shelves above creeks; Perennial; Flowering May-June; Fruiting June-Oct

Federal Status: State Status: SGCN: Y
Endemic: N Global Rank: G3 State Rank: S3

Texas fescue *Festuca versuta*

Occurs in mesic woodlands on limestone-derived soils on stream terraces and canyon slopes; Perennial; Flowering/Fruiting April-June

Federal Status: State Status: SGCN: Y
Endemic: N Global Rank: G3 State Rank: S3

Texas peachbush *Prunus texana*

Occurs at scattered sites in various well drained sandy situations; deep sand, plains and sand hills, grasslands, oak woods, 0-200 m elevation; Perennial; Flowering Feb-Mar; Fruiting Apr-Jun

Federal Status: State Status: SGCN: Y
Endemic: Y Global Rank: G3G4 State Rank: S3S4

Texas seymeria *Seymeria texana*

Found primarily in grassy openings in juniper-oak woodlands on dry rocky slopes but sometimes on rock outcrops in shaded canyons; Annual; Flowering May-Nov; Fruiting July-Nov

Federal Status: State Status: SGCN: Y
Endemic: Y Global Rank: G3 State Rank: S3

threeflower penstemon *Penstemon triflorus ssp. triflorus*

Occurs sparingly on rock outcrops and in grasslands associated with juniper-oak woodlands (Carr 2015).

Federal Status: State Status: SGCN: Y
Endemic: Y Global Rank: G3T3 State Rank: S3

tree dodder *Cuscuta exaltata*

Parasitic on various Quercus, Juglans, Rhus, Vitis, Ulmus, and Diospyros species as well as Acacia berlandieri and other woody plants; Annual; Flowering May-Oct; Fruiting July-Oct

Federal Status: State Status: SGCN: Y
Endemic: N Global Rank: G3 State Rank: S3

DISCLAIMER

The information on this web application is provided "as is" without warranty as to the currentness, completeness, or accuracy of any specific data. The data provided are for planning, assessment, and informational purposes. Refer to the Frequently Asked Questions (FAQs) on the application website for further information.

BEXAR COUNTY

PLANTS

turnip-root scurfpea	<i>Pediomelum cyphocalyx</i>	
Grasslands and openings in juniper-oak woodlands on limestone substrates on the Edwards Plateau and in north-central Texas (Carr 2015).		
Federal Status:	State Status:	SGCN: Y
Endemic: Y	Global Rank: G3G4	State Rank: S2S3
woolly butterfly-weed	<i>Gaura villosa ssp. parksii</i>	
Flats and hills of red sand of Rio Grande Plains (Raven and Gregory 1972). April-Oct.		
Federal Status:	State Status:	SGCN: Y
Endemic: Y	Global Rank: G5T3	State Rank: S3
Wright's milkvetch	<i>Astragalus wrightii</i>	
On sandy or gravelly soils; April (Diggs et al. 1999).		
Federal Status:	State Status:	SGCN: Y
Endemic: Y	Global Rank: G3	State Rank: S3

DISCLAIMER

The information on this web application is provided "as is" without warranty as to the currentness, completeness, or accuracy of any specific data. The data provided are for planning, assessment, and informational purposes. Refer to the Frequently Asked Questions (FAQs) on the application website for further information.

**SAN ANTONIO TRANSFER STATION
BEXAR COUNTY, TEXAS
TCEQ PERMIT NO. MSW-2420
TYPE V PERMIT APPLICATION
PART III
SITE DEVELOPMENT PLAN**

Prepared for

Waste Connections Lone Star, Inc.

January 2024

Revised May 2024

Revised July 2024

Revised September 2024



Prepared by

Weaver Consultants Group, LLC

TBPE Registration No. F-3727

6420 Southwest Boulevard, Suite 206

Fort Worth, Texas 76109

817-735-9770

WCG Project No. 0601-012-11-01

This document is issued for permitting purposes only.



CONTENTS

1	INTRODUCTION	III-1
1.1	Background	III-1
1.2	Site Location	III-1
1.3	Land Use and Zoning §330.63(a)	III-1
2	GENERAL FACILITY DESIGN	III-2
2.1	Facility Access	III-2
2.1.1	Adequacy of Access Roads and Highways §330.63(a)	III-2
2.1.2	Fences and Access Control §330.63(b)(1)	III-2
2.2	Waste Movement §330.63(b)(2)	III-3
2.2.1	Waste Flow Diagram §330.63(b)(2)(A)	III-3
2.2.2	Waste Process Schematic View §330.63(b)(2)(B)	III-3
2.2.3	Ventilation and Odor Control §330.63(b)(2)(C)	III-3
2.2.4	Generalized Construction Details §330.63(b)(2)(D) through (F)	III-3
2.2.5	Noise Pollution Control §330.63(b)(2)(I)	III-4
2.3	Sanitation and Water Pollution Control §330.63(b)(3) & (4)	III-4
2.3.1	Surface Water and Groundwater Protection §330.63(b)(3)(A) & (4)	III-4
2.3.2	Floor Wash Down §330.63(b)(3)(A) through (D)	III-4
2.4	Protection of Endangered Species §330.63(b)(5)	III-5
3	SURFACE WATER DRAINAGE REPORT §330.63(C)	III-6
3.1	Drainage Design §330.63(c)(1)	III-6
3.2	Floodplain Considerations §330.63(c)(2)	III-6
4	WASTE PROCESSING FACILITY DESIGN §330.63(D)(1)	III-7
4.1	Waste Operations §330.63(d)(1)(A)	III-7
4.2	Spill Prevention and Control §330.63(d)(1)(B)	III-7
4.3	Waste Storage Period §330.63(d)(1)(C)	III-8
5	CLOSURE PLAN §330.63(H)	III-9
6	COST ESTIMATE FOR CLOSURE §330.63(J)	III-10

CONTENTS (Continued)

APPENDIX IIIA GENERAL FACILITY DESIGN DRAWINGS

- Drawing IIIA-1 Proposed Site Plan
- Drawing IIIA-2 Transfer Area Site Plan
- Drawing IIIA-3 Sections Station Building Plan
- Drawing IIIA-4 Sections and Details
- Drawing IIIA-5 Screening Plan

APPENDIX IIIB FACILITY SURFACE WATER DRAINAGE REPORT

APPENDIX IIIC CLOSURE PLAN

APPENDIX IIID COST ESTIMATE FOR CLOSURE



1 INTRODUCTION

This Part III – Site Development Plan (SDP) has been prepared for the San Antonio Transfer Station (TS) consistent with Title 30 Texas Administrative Code (TAC) §330.63.

Part III – SDP addresses the general facility design, closure plan, and cost estimate for closure. Site design plans for the San Antonio TS are presented in Appendix IIIA – General Facility Design Drawings.

This section addresses §330.63. Additional specific regulatory citations are indicated within the Part III subsection headings.

1.1 Background

The San Antonio TS will provide an efficient means to process and transfer the waste that is generated in the City of San Antonio, Bexar County, and the surrounding areas and transfer the waste to a Texas Commission on Environmental Quality (TCEQ) permitted MSW landfill. Support facilities for the San Antonio TS include a site entrance road, scale house, collection and transfer equipment parking/staging area, transfer station building.

1.2 Site Location

The San Antonio TS will be located in the Extra Territorial Jurisdiction (ETJ) area of San Antonio in Bexar County, Texas. The transfer station will be located at 10244 FM 1346, Adkins, Texas approximately 1.5 miles west of the intersection of FM 1604 and FM 1346. The site location is shown on Figure I/II-4.1.

1.3 Land Use and Zoning §330.63(a)

Information related to zoning of the TS property is provided in Part I/II, Section 7. The property is located within San Antonio's ETJ and is currently un-zoned.

2 GENERAL FACILITY DESIGN

2.1 Facility Access

2.1.1 Adequacy of Access Roads and Highways §330.63(a)

Vehicles bound for the San Antonio TS will access the TS from one of two existing driveways on FM 1346. Most vehicles will utilize Interstate Highway 10 and FM 1604 to get to FM 1346 and the site entrance. Other roads (i.e., Stuart Road) may be periodically used by collection vehicles to serve residences and businesses located along or near these roadways; however, these roads are not main access roads that other collection vehicles will routinely use to access the site.

Interstate Highway 10, FM 1604, and FM 1346 are public roads and are maintained by the Texas Department of Transportation (TxDOT). As noted in Parts I/II, Section 8.0 and in the Traffic Study included in Appendix I/IIA the site access roads will provide adequate access throughout the life of the facility. In accordance with Title 30 TAC §330.61(i)(4), TxDOT was contacted to determine if any traffic or location restrictions apply to the facility. The TxDOT coordination information is included in Parts I/II, Appendix I/IIA.

2.1.2 Fences and Access Control §330.63(b)(1)

Vehicle access to the TS will be controlled by the scale house attendant during operating hours. An attendant will be on site during all operating hours to regulate access to the TS. Outside of operating hours, a gate is located across the facility entrance road north of the scale house to prevent unauthorized vehicle access. The height and material for the entrance gate may vary. The scale house entrance will be locked to prevent unauthorized access. Vehicle access to the site at points other than the entry gate will be minimized by suitable fencing, which will be a chain link, barbed wire, or other acceptable fencing.

Waste Connections Lone Star, Inc.'s (WCLSI) policy will restrict entry to the site only to designated site operations personnel, solid waste haulers authorized to use the facility, TCEQ personnel, and properly identified persons whose entry is authorized by the TS Manager. Lealco reserves the right to restrict access to the site to persons not demonstrating a legitimate purpose for visiting. Visitors are allowed only when accompanied by a Lealco representative.

WASTE FLOW DIAGRAM

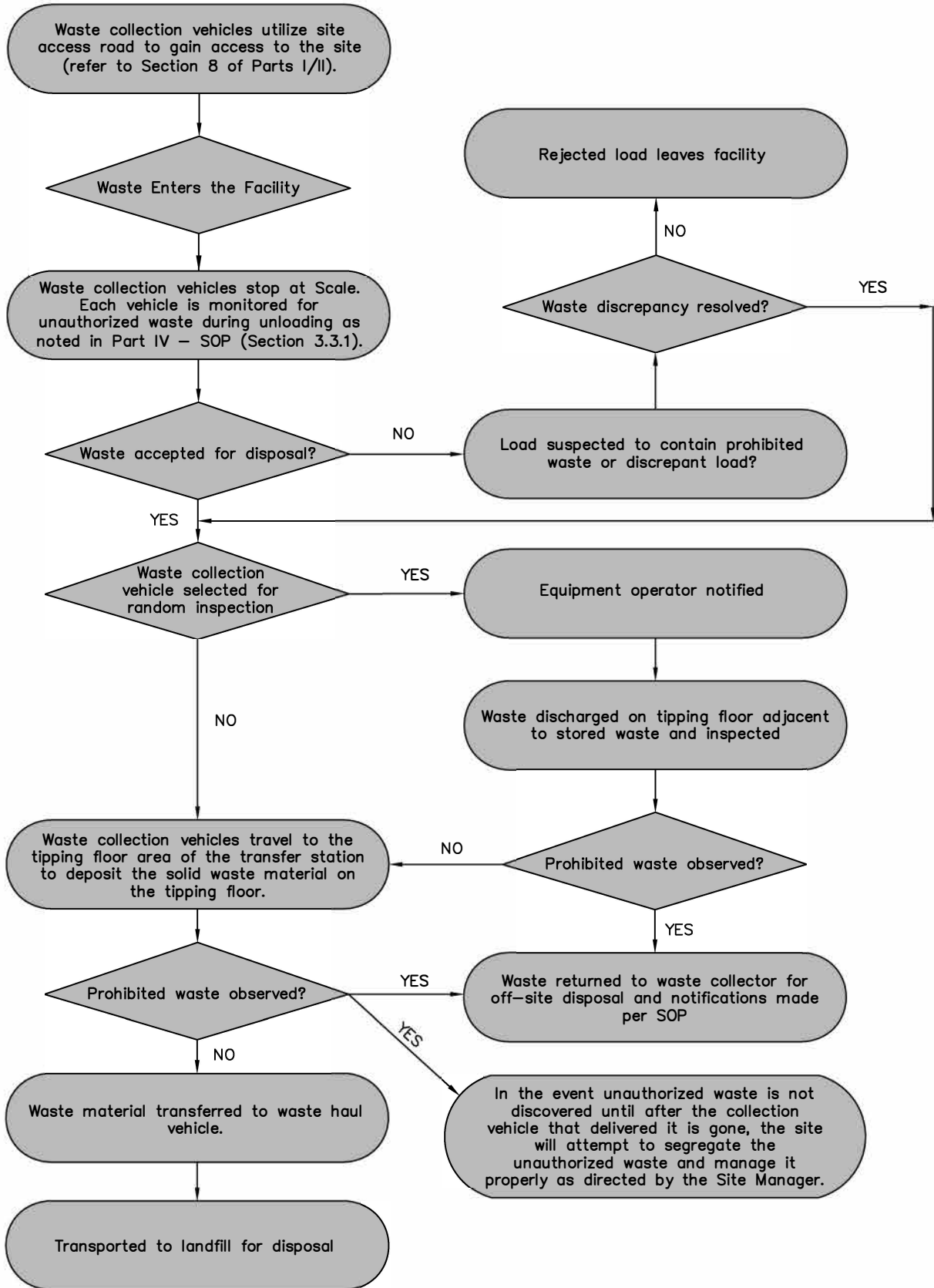

FIGURE III-2.1

0:\0601\12\TYPE V APPLICATION\PART III\FIG 2.1-WASTE FLOW DIAGRAM.dwg, ca/weaver, 1:1

2.2 Waste Movement §330.63(b)(2)

2.2.1 Waste Flow Diagram §330.63(b)(2)(A)

A waste flow diagram indicating the processing, storage, and disposal sequences for various types of wastes received is shown on Figure III-2.1.

2.2.2 Waste Process Schematic View §330.63(b)(2)(B)

A schematic view indicating the phases, waste processing, storage, and disposal as applicable, is shown on Drawings IIIA-2 and IIIA-3 in Appendix IIIA. These drawings include the layout of the TS within the 7.51-acre Permit boundary and the traffic flow patterns.

2.2.3 Ventilation and Odor Control §330.63(b)(2)(C)

The TS structure is designed to provide adequate ventilation. The north and south sides of the structure are open. No significant air pollution emissions are expected to result from the operation of the TS.

The TS is operated to provide adequate ventilation for odor control and employee safety. The operator will prevent nuisance odors from leaving the TS Permit boundary. If nuisance odors are detected near the TS Permit boundary, the site will take action to abate the condition. Odors are controlled by limiting operations to within the structure and limiting the time solid waste may be stored on the tipping floor (refer to Part IV – SOP, Section 8.10). All processing of solid waste will occur within the TS structure. Mist systems may be used within the TS structure to suppress odors, if needed. The mist (or similar) systems may also be used to control odors through the addition of chemical deodorizers. Ponding water will be controlled to avoid objectionable odors.

2.2.4 Generalized Construction Details §330.63(b)(2)(D) through (F)

The TS will consist of a metal structure with a total tipping floor area of approximately 19,500 square feet. The structure covers a reinforced concrete pad (tipping floor) used for waste processing. The tipping floor is designed with a slope to drain toward the west. The north and south sides of the building have openings for entrance to the tipping floor for collection vehicles. Contaminated water collected on the tipping floor will drain to the opening on the west of the tipping floor. As shown on Figure IIIA-3 (Appendix IIIA), a sump will collect contaminated water, which will then be conveyed to a minimum 500-gallon grit trap/oil water separator. -The grit trap will be emptied of captured sediment and oil by a vacuum truck that will haul this material offsite to a permitted facility for disposal. This will occur as necessary to allow proper operation of the TS. Water passing through the separator will flow by gravity or via a pumped forcemain (minimum 5 gpm) to a minimum 2,000-gallon holding tank.

Waste grease, oil, or sludge will not be received or accepted at the TS.

2.2.5 Noise Pollution Control §330.63(b)(2)(I)

Since TS activities take place within the structure, generated noise is mostly confined to the structure. Waste transfer operations are screened and buffered from the public by existing dense trees and bushes, as well as an 8' screening fence on portions of the facility perimeter bordering existing residents. WCLSI will utilize OSHA-approved "white noise" or similar backup alarms on mobile TS equipment as practicable. The TS structure is located at a sufficient distance from nearby residences and businesses so that activities at the site are not readily visible. The Permit boundary is located approximately 50 feet from the nearest residence, with the TS structure located approximately 180 feet from the nearest residence/business. A Facility Screening Plan is provided as Figure IIIA-5.

2.3 Sanitation and Water Pollution Control §330.63(b)(3) & (4)

The TS structure will include a metal roof that covers the concrete slab waste processing area (tipping floor) and the waste storage area. Waste will be unloaded and processed on the concrete tipping floor. As shown on Figure IIIA-3 (Appendix IIIA), a 50-gallon (minimum) sump will collect contaminated water from the tipping floor, which will then convey it to a minimum 500-gallon grit trap/oil water separator then to a minimum 2,000-gallon holding tank. As discussed in Appendix IIIB, the TS site will be graded to prevent run-on drainage and flow of stormwater onto the tipping floor.

2.3.1 Surface Water and Groundwater Protection §330.63(b)(3)(A) & (4)

As discussed in the Parts I/II, Section 10, the TS site is designed to prevent discharge of pollutants into waters of the United States, as defined by the Texas Water Code and the Federal Clean Water Act, respectively. The facility will be constructed, maintained, and operated to manage run-on and runoff during the peak discharge of a 25-year rainfall event and prevent the off-site discharge of waste material, including, but not limited to, in-process and/or processed materials. Surface water drainage in and around the facility will be controlled to prevent surface water from running into, onto, and off the processing area. Since all contaminated water is managed in a controlled manner, as discussed above, groundwater is protected.

2.3.2 Floor Wash Down §330.63(b)(3)(A) through (D) and §330.243(a)

Waste processing operations within the TS structure will be conducted on a covered tipping floor. All walls and floors in operating areas will be constructed of masonry, concrete, or other hard-surfaced materials that will be washed at least weekly with a pressure washer and/or powered floor sweeper. A one-hour wash with a pressure washer flowrate of 5 gpm produces an expected wastewater output of 300-350 gallons per week. Waste water will drain through a sump and be directed to an oil/water separator then to a minimum 2,000-gallon contaminated water holding tank.

2.4 Protection of Endangered Species §330.63(b)(5)

Since the majority of the TS will be located on disturbed land and based on the findings from the recent wildlife study, it was determined that no threatened or endangered species exist within the property boundary. Additional discussion regarding threatened or endangered species is provided in Parts I/II, Section 12.

3 SURFACE WATER DRAINAGE REPORT §330.63(c)

3.1 Drainage Design §330.63(c)

The TS will be constructed, maintained, and operated to manage run-on and runoff during the peak discharge of a 25-year storm event and prevent the off-site discharge of waste material, including, but not limited to, in-process and/or processed materials. Surface water drainage in and around the facility will be controlled to minimize surface water running onto, into, and off the processing area. Details of the drainage system and associated design demonstrations are included in Appendix IIIB, Surface Water Drainage Report.

3.2 Floodplain Considerations §330.63(c)

As shown on Figure I/II-11.1, the TS area is not located within a 100-year floodplain as defined by FEMA.

4 WASTE PROCESSING FACILITY DESIGN §330.63(D)(1)

4.1 Waste Operations §330.63(d)(1)(A)

The TS is designed for efficient waste processing. The building footprint will be 150 feet by 130 feet with a maximum limit of waste acceptance of 2,500 tons per day.

All solid waste capable of creating public health hazards or nuisances will be stored within the building, processed or transferred promptly, and will not be allowed to result in a nuisance or public health hazard. All solid waste stored overnight at the facility will either be in a transfer trailer with a tarp over it or on the tipping floor with a tarp over it. Recyclable materials on the tipping floor or within enclosed containers will not require tarping.

The scale house attendant directs incoming waste collection traffic to the tipping floor or unloading area of the TS once the incoming vehicle's weight or volume has been recorded. The scale house attendant informs the customer that the waste is only to be unloaded in the area where the customer is directed by site operating personnel to unload. Signs directing traffic from the scale house to the TS structure are located, as needed, along the route to the unloading areas. The unloading of waste is directed by personnel working inside the TS. Equipment operators and other personnel are on duty during operating hours to direct traffic to the unloading areas.

Unloading of waste in unauthorized areas is prohibited. Any waste that is identified as having been deposited in an unauthorized area will be immediately moved to the proper unloading areas.

Prohibited waste is not allowed to enter the site. The scale house attendant is the first point of contact with the hauler. The hauler is asked to inform the scale house attendant of the content of the load. The scale house attendant visually inspects containers to verify contents. In the event prohibited wastes are identified in the load, the entire load will be turned away from the gate and not allowed entrance to the site. Prohibited waste identified as having been dumped onto the TS floor will be managed in accordance with Section 8.2.1 in Part IV.

4.2 Spill Prevention and Control §330.63(d)(1)(B)

Staging and processing areas at this facility will be located within the TS structure. The unloading areas are designed to control and contain spills and contaminated

water. Contaminated water generated by the TS consists of washdown water applied to the tipping floor. The tipping floor is designed to control and contain spills and contaminated water. Contaminated water is conveyed from the tipping floor to a sump with a capacity of approximately 50 gallons, to a minimum 500-gallon oil/water separator and then to minimum 2,000-gallon holding tank, which is pumped by a registered hauler and transported to a permitted waste water treatment facility for disposal. The combined storage capacity of the holding tank, grit separator, and sump will be at minimum 2,500 gallons, sufficient to store approximately seven weeks of contaminated water generated onsite.

4.3 Waste Storage Period §330.63(d)(1)(A) and (C)

The facility will not accumulate solid waste in quantities that cannot be processed within such time as will preclude the creation of odors, insect breeding, or harborage of other vectors. Solid waste will be stored in a manner to prevent fires, ensure safety, prevent a health hazard, or preclude food or harborage for animals and vectors, and contained to minimize windblown solid waste and litter. Solid waste will be stored either in a transfer trailer with a tarp cover or on the tipping floor with a tarp cover. The maximum time waste material will be stored will not exceed 48 hours for the TS, except on holidays or weekends. On holidays and/or weekends the maximum time will not exceed 72 hours.

5 CLOSURE PLAN §330.63(H)

A closure plan is included in Appendix IIIC.

6 COST ESTIMATE FOR CLOSURE §330.63(J)

A cost estimate for the final closure of the facility is included as Appendix IIID. The estimated cost is \$208,150 in 2023 dollars.

**SAN ANTONIO TRANSFER STATION
BEXAR COUNTY, TEXAS
TCEQ PERMIT NO. MSW-2420
TYPE V PERMIT APPLICATION
PART III
SITE DEVELOPMENT PLAN
APPENDIX IIIA
GENERAL FACILITY DESIGN DRAWINGS**

Prepared for
Waste Connections Lone Star, Inc.

January 2024
Revised May 2024

Revised July 2024

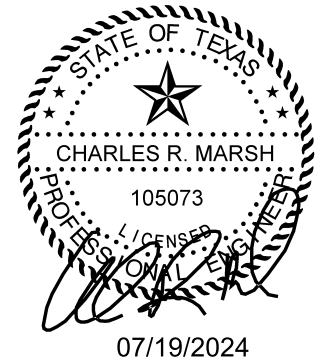

Prepared by
Weaver Consultants Group, LLC
TBPE Registration No. F-3727
6420 Southwest Boulevard, Suite 206
Fort Worth, Texas 76109
817-735-9770

WCG Project No. 0601-012-11-01

This document is issued for permitting purposes only.

CONTENTS

Drawing IIIA-1	Proposed Site Plan
Drawing IIIA-2	Transfer Area Site Plan
Drawing IIIA-3	Sections Station Building Plan
Drawing IIIA-4	Sections and Details
Drawing IIIA-5	Screening Plan



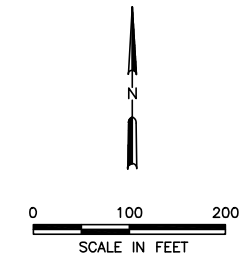
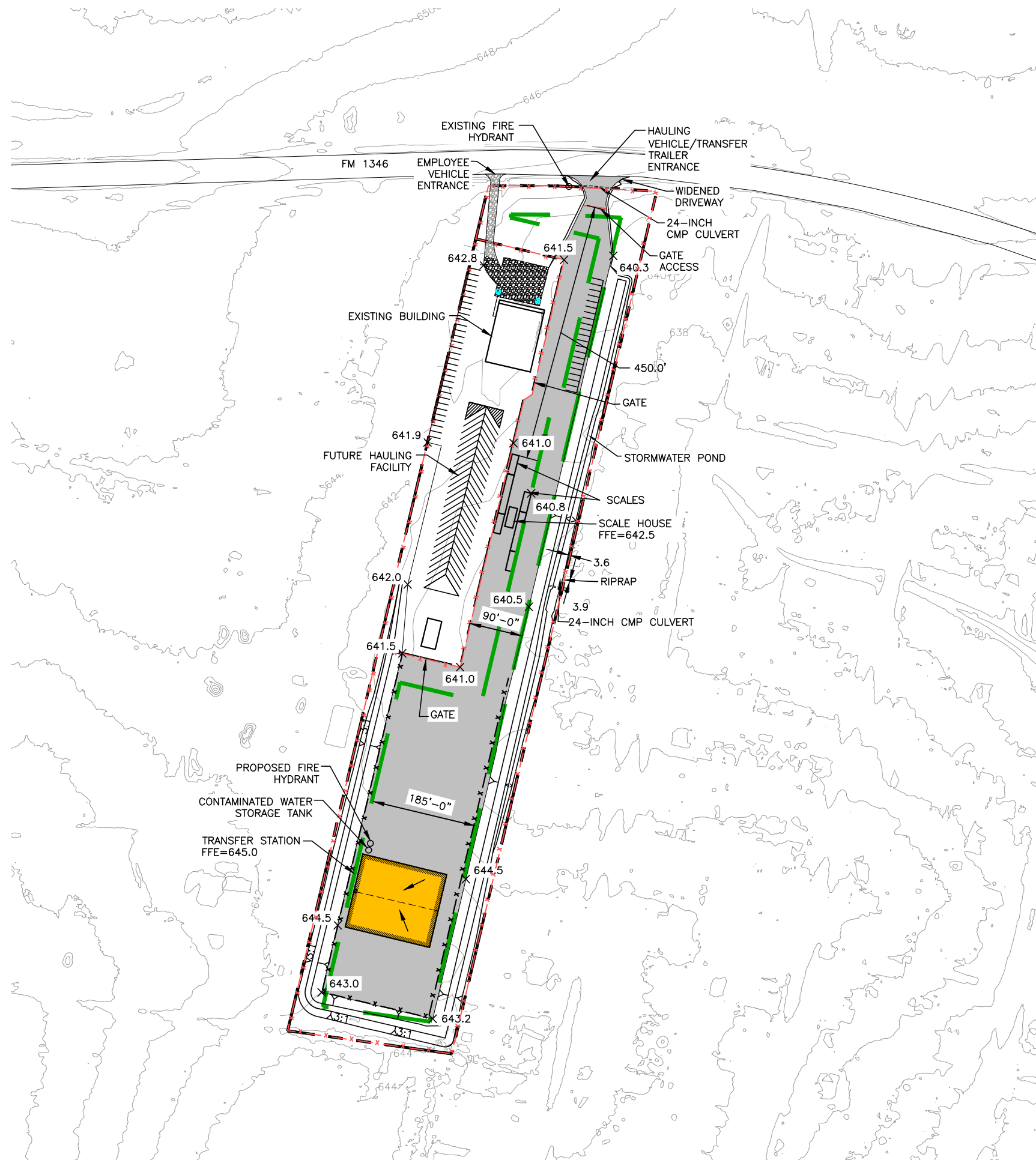

LEGEND

	PERMIT BOUNDARY
	PROPERTY BOUNDARY
	EXISTING CONTOUR
	PROPOSED BUILDING
	EXISTING GRAVEL PAVEMENT
	PROPOSED GRAVEL PAVEMENT
	50-FOOT BUFFER ZONE
	ACCESS CONTROL FENCE (SEE NOTE 3)
	PROPOSED OPERATIONS AREA FENCE (SEE NOTE 2)
	PROPOSED CONCRETE OR ASPHALT PAVEMENT OR AGGREGATE SURFACE
	PROPOSED SPOT ELEVATION

- NOTES:**
1. THE EXISTING CONTOURS PROVIDED BY TEXAS RESOURCE INFORMATION SYSTEM (TNRIS) BEXAR AND TRAVIS COUNTIES LIDAR, 2022.
 2. THE TRANSFER STATION ACCESS WILL BE CONTROLLED BY A FENCE AROUND THE PROPERTY WITH GATES ON THE FACILITY ENTRANCE ROAD. AREAS WITH DENSE TREES PROVIDE A NATURAL BARRIER AROUND THE EAST SIDE OF THE FACILITY BOUNDARY.
 3. PERIMETER FENCE ACCESS POINTS MAY BE INSTALLED TO FACILITATE SITE MAINTENANCE AND OPERATIONS.

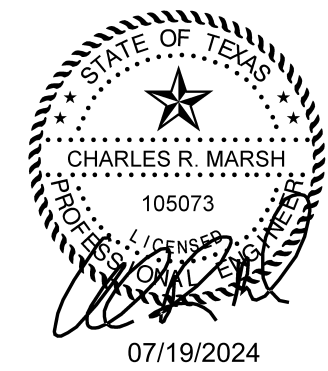

Tech. Complete App. - 310

<input type="checkbox"/> 90% REVIEW <input checked="" type="checkbox"/> FOR PERMITTING PURPOSES ONLY <input type="checkbox"/> ISSUED FOR CONSTRUCTION	PREPARED FOR		TYPE V PERMIT APPLICATION PROPOSED SITE PLAN SAN ANTONIO TRANSFER STATION BEXAR COUNTY, TEXAS
	WASTE CONNECTIONS LONE STAR, INC.		
DATE: 01/2024 FILE: 0601-012-11 CAD: IIIA-1-PROPOSED SITE PLAN.DWG	DRAWN BY: RAA DESIGN BY: MB REVIEWED BY: CRM	REVISIONS	
Weaver Consultants Group TBPE REGISTRATION NO. F-3727		NO. 1 DATE 05/2024 DESCRIPTION PERMIT MODIFICATION	WWW.WCGRP.COM FIGURE IIIA-1

O:\0601\12\TYPE V PERMIT APP\FART IIIA\CLEAN (07-2024)\III A-1 PROPOSED SITE PLAN.dwg, Farrington, 1:2

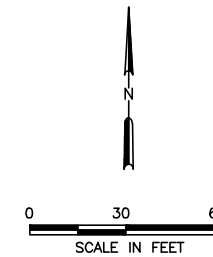

LEGEND

	PERMIT BOUNDARY
	EXISTING CONTOUR
	PROPOSED BUILDING
	PROPOSED CONCRETE OR ASPHALT PAVEMENT OR AGGREGATE SURFACE
	PROPOSED SPOT ELEVATION
	TRANSFER TRAILER ROUTE
	ROUTE TRUCK/UNLOADING ROUTE
	SCREENING AND ACCESS CONTROL FENCE (SEE NOTE 3)

NOTES:

1. THE EXISTING CONTOURS PROVIDED BY TEXAS RESOURCE INFORMATION SYSTEM (TNRIS) BEXAR AND TRAVIS COUNTIES LIDAR, 2022.
2. THE TRANSFER STATION ACCESS WILL BE CONTROLLED BY A FENCE AROUND THE PROPERTY WITH GATES ON THE FACILITY ENTRANCE ROAD. AREAS WITH DENSE TREES PROVIDE A NATURAL BARRIER AROUND THE EAST SIDE OF THE FACILITY BOUNDARY.
3. PERIMETER FENCE ACCESS POINTS MAY BE INSTALLED TO FACILITATE SITE MAINTENANCE AND OPERATIONS.
4. THE PROPERTY BOUNDARY IS COINCIDENT WITH THE PERMIT BOUNDARY FOR THE PORTION OF THE SITE DEPICTED.
5. THE FIRE HYDRANT MAY BE RELOCATED OR SUBSTITUTED FOR A STORAGE TANK IF REQUIRED BY THE FIRE MARSHAL.



Tech. Complete App. - 311

<input type="checkbox"/> 90% REVIEW <input checked="" type="checkbox"/> FOR PERMITTING PURPOSES ONLY <input type="checkbox"/> ISSUED FOR CONSTRUCTION		PREPARED FOR WASTE CONNECTIONS LONE STAR, INC.		TYPE V PERMIT APPLICATION TRANSFER AREA SITE PLAN SAN ANTONIO TRANSFER STATION BEXAR COUNTY, TEXAS			
DATE: 01/2024 FILE: 0601-012-11 CAD: IIIA-1-PROPOSED SITE PLAN.DWG		DRAWN BY: RAA DESIGN BY: MB REVIEWED BY: CRM					
Weaver Consultants Group TBPE REGISTRATION NO. F-3727		REVISIONS		WWW.WCGRP.COM			
		<table border="1"> <thead> <tr> <th>NO.</th> <th>DATE</th> <th>DESCRIPTION</th> </tr> </thead> <tbody> <tr> <td>1</td> <td>09/2024</td> <td>PERMIT MODIFICATION</td> </tr> </tbody> </table>				NO.	DATE
NO.	DATE	DESCRIPTION					
1	09/2024	PERMIT MODIFICATION					
				FIGURE IIIA-2			

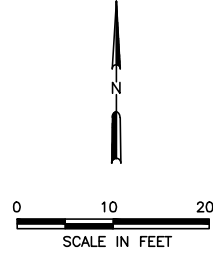
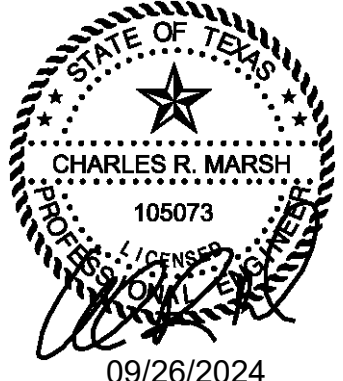

- LEGEND**
- 640 EXISTING CONTOUR
 - PROPOSED BUILDING
 - PROPOSED CONCRETE OR ASPHALT PAVEMENT OR AGGREGATE SURFACE
 - 642.0 PROPOSED SPOT ELEVATION
 - FLOW DIRECTION
 - INDICATES REVISION

- NOTES:**
1. THE EXISTING CONTOURS PROVIDED BY TEXAS RESOURCE INFORMATION SYSTEM (TNRIS) BEXAR AND TRAVIS COUNTIES LIDAR, 2022.
 2. THE TRANSFER STATION ACCESS WILL BE CONTROLLED BY A FENCE AROUND THE PROPERTY WITH GATES ON THE FACILITY ENTRANCE ROAD. AREAS WITH DENSE TREES PROVIDE A NATURAL BARRIER AROUND THE EAST SIDE OF THE FACILITY BOUNDARY.
 3. PERIMETER FENCE ACCESS POINTS MAY BE INSTALLED TO FACILITATE SITE MAINTENANCE AND OPERATIONS.
 4. THE FIRE HYDRANT MAY BE RELOCATED OR SUBSTITUTED FOR A STORAGE TANK IF REQUIRED BY THE FIRE MARSHAL.

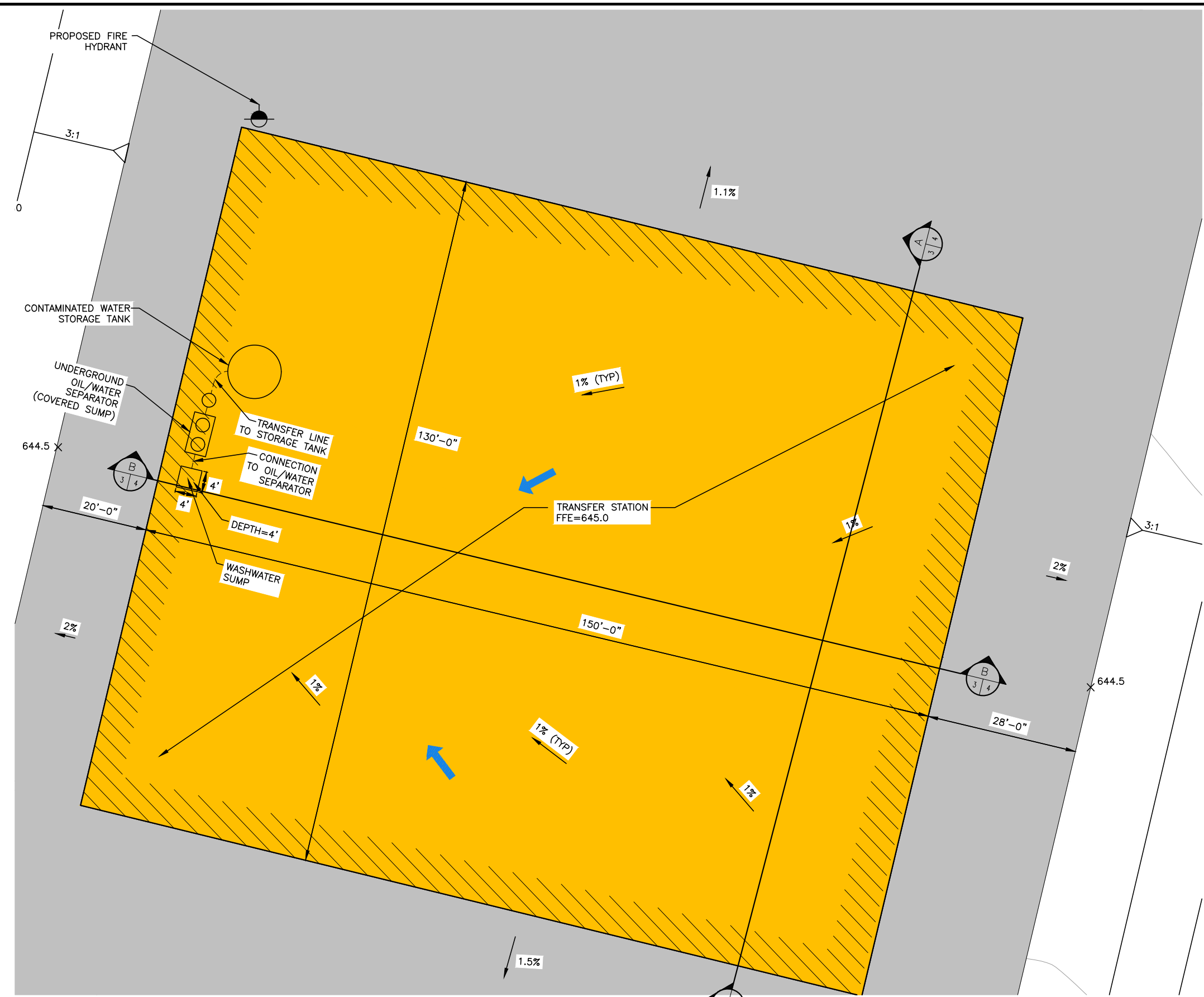

Tech. Complete App. - 312

<input type="checkbox"/> 90% REVIEW <input checked="" type="checkbox"/> FOR PERMITTING PURPOSES ONLY <input type="checkbox"/> ISSUED FOR CONSTRUCTION	PREPARED FOR		WASTE CONNECTIONS LONE STAR, INC. TYPE V PERMIT APPLICATION TRANSFER STATION BUILDING PLAN SAN ANTONIO TRANSFER STATION BEXAR COUNTY, TEXAS
	DATE: 01/2024 FILE: 0601-012-11 CAD: IIIA-3-PROPOSED SITE PLAN.DWG		
DRAWN BY: RAA DESIGN BY: MB REVIEWED BY: CRM	REVISIONS		WWW.WCGRP.COM
Weaver Consultants Group TBPE REGISTRATION NO. F-3727	NO. 1	DATE 09/2024	
FIGURE IIIA-3			FIGURE IIIA-3

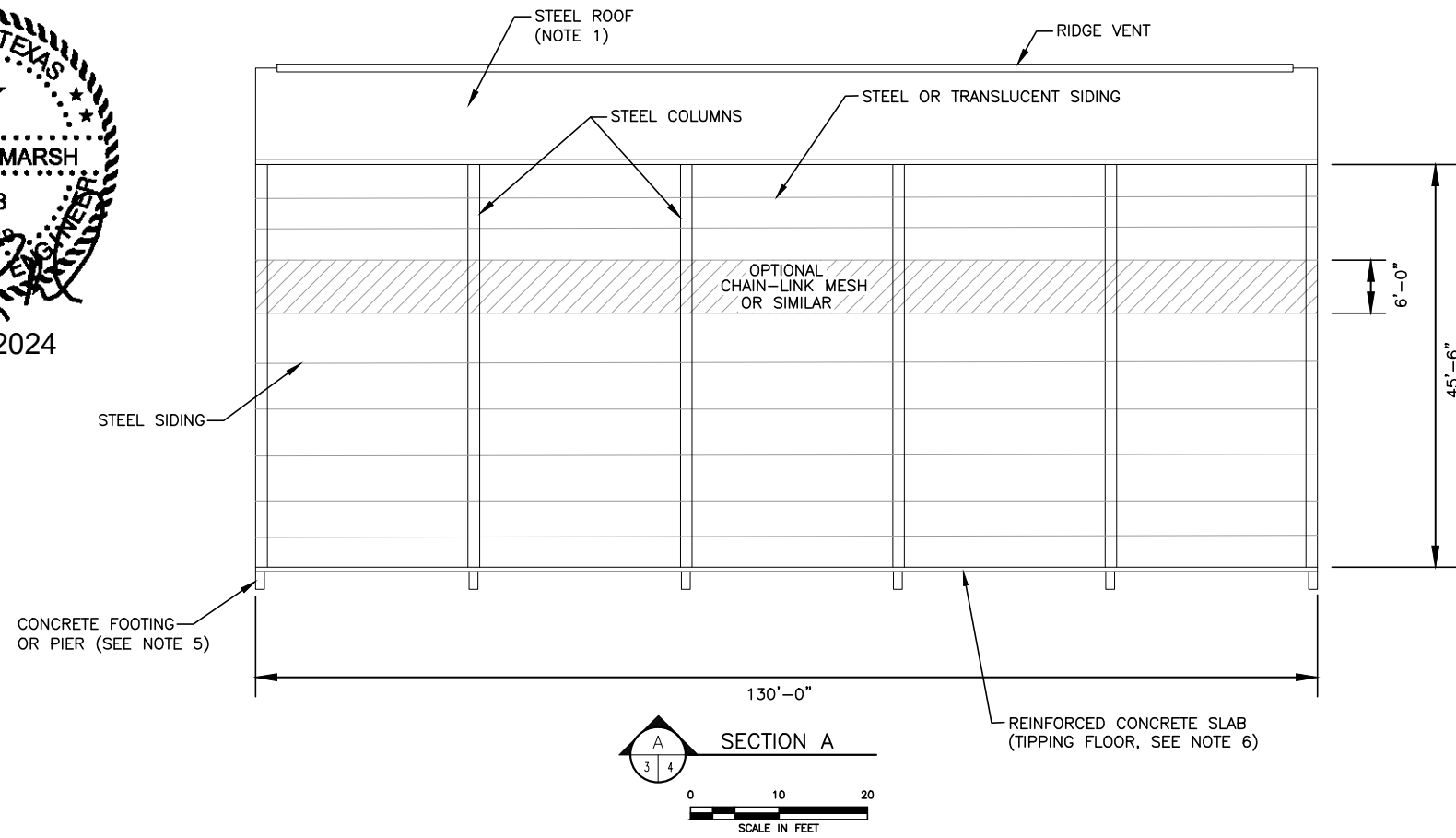
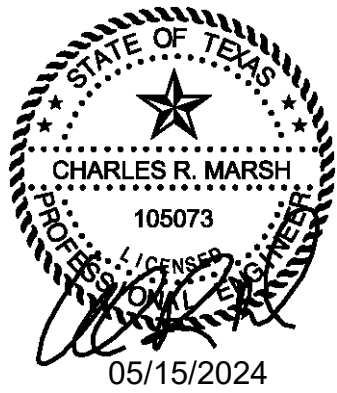

SECTION A
SCALE IN FEET

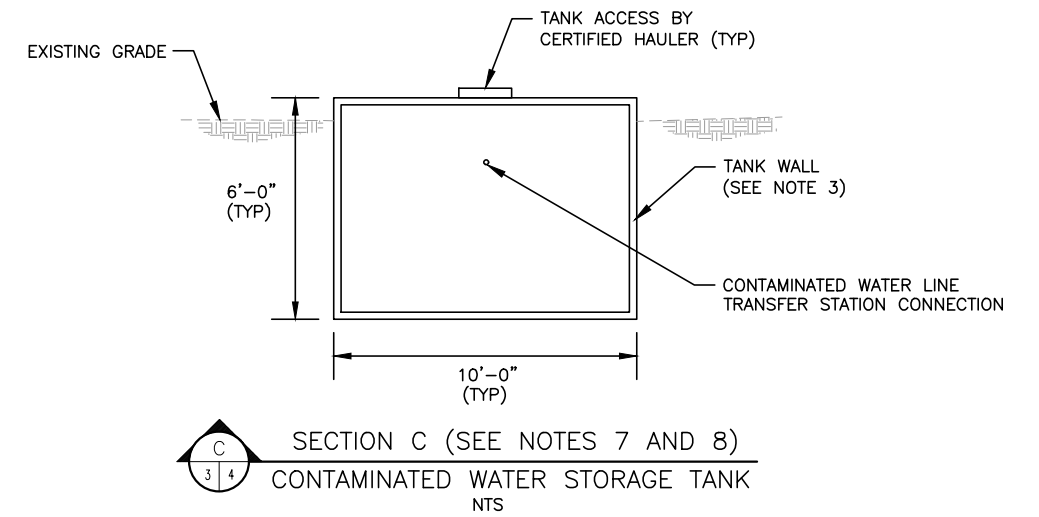

SECTION C (SEE NOTES 7 AND 8)
CONTAMINATED WATER STORAGE TANK
NTS

NOTES:

1. TRANSLUCENT PANELS MAY BE USED ON PORTIONS OF ROOF.
2. DIMENSIONS SHOWN ARE APPROXIMATE.
3. BUILDING IS A PRE-FABRICATED STEEL BUILDING DESIGNED AND CONSTRUCTED TO CURRENT BUILDING CODES.
4. BUILDING DIMENSIONS AND MATERIALS MAY VARY FROM AS SHOWN IN SECTIONS.
5. TRANSFER STATION BUILDING FOUNDATION BEARING PRESSURES AND CONFIGURATIONS WILL BE DETERMINED BASED ON A GEOTECHNICAL INVESTIGATION AND ANALYSES PERFORMED FOR THE BUILDING AND FOUNDATION LOADING CONCURRENT WITH PREPARATION OF CONSTRUCTION-LEVEL DESIGNS OF THE STRUCTURE. THE BUILDING FOUNDATIONS WILL BE EITHER SHALLOW SPREAD FOOTINGS, DRILLED SHAFT OR DRIVEN PILES. THE FOUNDATIONS WILL BE DESIGNED AND CONSTRUCTED TO CONFORM WITH ALL APPLICABLE STATE AND LOCAL BUILDING CODES AND REQUIREMENTS.
6. CONCRETE TIPPING FLOOR WILL BE A MINIMUM 8-INCH THICK CONCRETE WITH STEEL REBAR REINFORCING. THE FLOOR CONCRETE WILL HAVE A MINIMUM 28-DAY COMPRESSIVE STRENGTH OF 3,500 PSI. THE CONCRETE THICKNESS AND RECOMMENDED REINFORCING DETAIL WILL BE PROVIDED AS AN ELEMENT OF THE GEOTECHNICAL ANALYSES DISCUSSED FOR NOTE 5, ABOVE. THE CONCRETE TIPPING FLOOR WILL BE DESIGNED TO PROVIDE A PERFORMANCE LIFE, AND WILL BE SUITABLE FOR PLACEMENT OF OVERLAY RESURFACING LAYERS IF REQUIRED DURING THE ACTIVE LIFE OF THE TRANSFER STATION.
7. CONTAMINATED WATER HOLDING TANKS DO NOT RECEIVE ANY RUNOFF - CLOSED SYSTEM WHICH RECEIVE ONLY WASHDOWN WATER FROM WITHIN THE TRANSFER STATION BUILDING. CONTAMINATED WATER STORAGE TANK WALLS WILL BE PLASTIC OR SIMILAR MATERIALS TO PREVENT SEEPAGE. THE DIMENSIONS SHOWN ARE TYPICAL; HOWEVER, MINIMUM TANK CAPACITY OF 2,000 GALLONS WILL BE PROVIDED.
8. CONTAMINATED WATER HOLDING TANK IS SHOWN BELOW GRADE FOR ILLUSTRATIVE PURPOSES ONLY. THE TANK WILL BE INSTALLED TO MEET ANY LOCAL AND STATE REQUIREMENTS AT THE TIME OF INSTALLATION.
9. THE STORAGE TANK RECEIVING CONTAMINATED WASH WATER WILL BE DUAL-CONTAINED OR CONSTRUCTED WITH SECONDARY CONTAINMENT, AND INCLUDE LEAK DETECTION WITH LEAK DETECTION MONITORING, AND MEANS TO PREVENT TANK SPILLAGE OR LEAKING DURING HIGH LEVEL EVENTS (AN ABOVE GRADE RISER FOR LIQUIDS REMOVAL AS AN EXAMPLE). THE STORAGE TANK WILL BE CONSTRUCTED OF MATERIALS DEMONSTRATED TO RESIST CORROSION OR DEGRADATION FROM CONTACT WITH LEACHATE OR OTHER WASTE-RELATED LIQUIDS (HIGH-DENSITY POLYETHYLENE OR FIBERGLASS AS EXAMPLES). DOCUMENTATION OF THE TANK DESIGN, LEAK DETECTION, AND CORROSION RESISTANCE SHALL BE PLACED INTO THE SITE OPERATING RECORD FOR THE FACILITY.
10. DISPOSAL OF SANITARY WASTEWATER AND CONTAMINATED WATER MAY BE TO FUTURE SANITARY SEWER SERVICE CONNECTION INSTALLED AND SERVING THE PROPERTY.

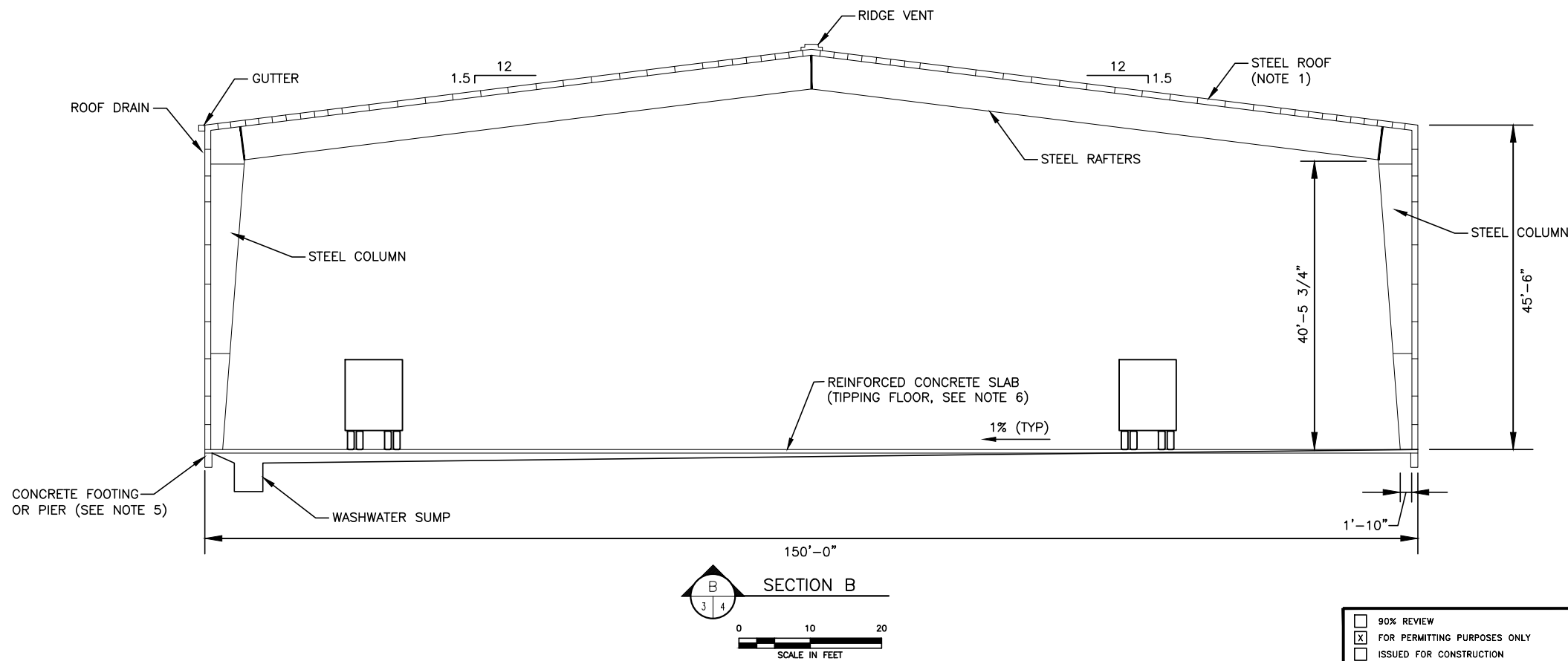

SECTION B
SCALE IN FEET

<input type="checkbox"/> 90% REVIEW <input checked="" type="checkbox"/> FOR PERMITTING PURPOSES ONLY <input type="checkbox"/> ISSUED FOR CONSTRUCTION	PREPARED FOR		WASTE CONNECTIONS LONE STAR, INC.	TYPE V PERMIT APPLICATION SECTIONS AND DETAILS	
	DATE: 01/2024 FILE: 0601-012-11 CAD: 4-SECTIONS A AND B.DWG				
Weaver Consultants Group TBPE REGISTRATION NO. F-3727		REVISIONS		SAN ANTONIO TRANSFER STATION BEXAR COUNTY, TEXAS	
		NO.	DATE		
		1	05/2024	PERMIT MODIFICATION	WWW.WCGRP.COM

Tech. Complete App. - 313

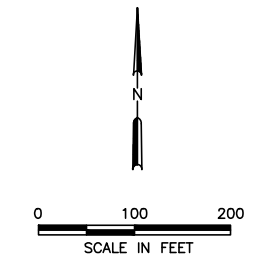
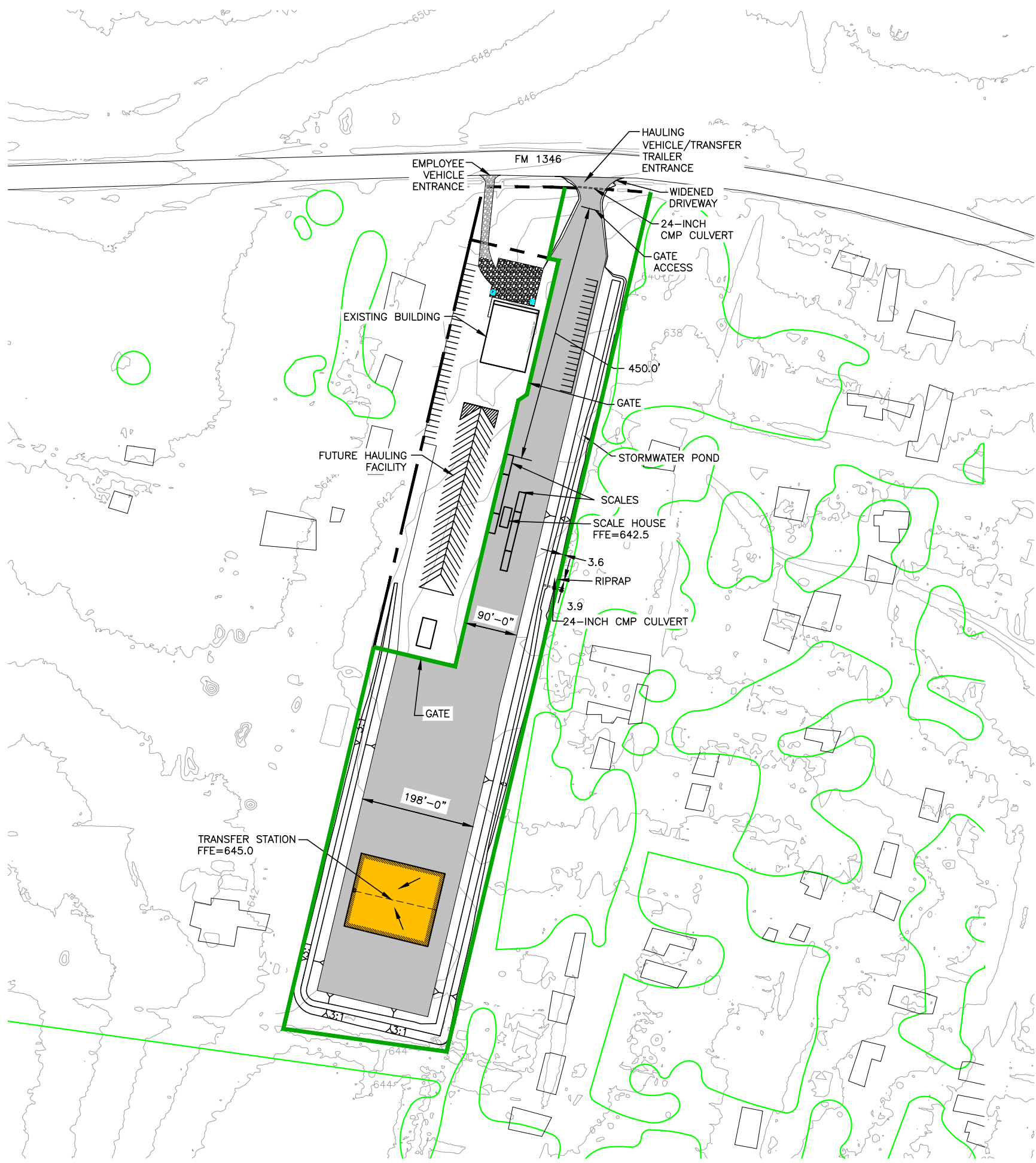

LEGEND

	PERMIT BOUNDARY
	PROPERTY BOUNDARY
	EXISTING CONTOUR
	PROPOSED BUILDING
	EXISTING GRAVEL PAVEMENT
	PROPOSED GRAVEL PAVEMENT
	PROPOSED CONCRETE OR ASPHALT PAVEMENT OR AGGREGATE SURFACE
	EXISTING TREES
	EXISTING BUILDING
	SCREENING AND ACCESS CONTROL FENCE (SEE NOTE 4)

- NOTES:**
1. THE EXISTING CONTOURS PROVIDED BY TEXAS RESOURCE INFORMATION SYSTEM (TNRIS) BEXAR AND TRAVIS COUNTIES LIDAR, 2022.
 2. THE TRANSFER STATION ACCESS WILL BE CONTROLLED BY A FENCE AROUND THE PROPERTY WITH GATES ON THE FACILITY ENTRANCE ROAD. AREAS WITH DENSE TREES PROVIDE A NATURAL BARRIER AROUND THE EAST SIDE OF THE FACILITY BOUNDARY.
 3. PERIMETER FENCE ACCESS POINTS MAY BE INSTALLED TO FACILITATE SITE MAINTENANCE AND OPERATIONS.
 4. SCREENING FENCE TO BE INSTALLED ALONG PORTIONS OF THE SOUTHERN, WESTERN, AND EASTERN PERIMETERS. DOWNCAST LIGHT FIXTURES WILL BE USED TO PREVENT MIGRATION OF LIGHTING.

Tech. Complete App. - 314

<input type="checkbox"/> 90% REVIEW <input checked="" type="checkbox"/> FOR PERMITTING PURPOSES ONLY <input type="checkbox"/> ISSUED FOR CONSTRUCTION	PREPARED FOR WASTE CONNECTIONS LONE STAR, INC.		TYPE V PERMIT APPLICATION SCREENING PLAN SAN ANTONIO TRANSFER STATION BEXAR COUNTY, TEXAS	
	DATE: 01/2024 FILE: 0601-012-11 CAD: IIIA-5-SCREENING PLAN.DWG			
Weaver Consultants Group TBPE REGISTRATION NO. F-3727	DRAWN BY: RAA DESIGN BY: MB REVIEWED BY: CRM	NO. 1	DATE 05/2024	DESCRIPTION PERMIT MODIFICATION
		NO. 1	DATE 09/2024	DESCRIPTION PERMIT MODIFICATION
		WWW.WCGRP.COM		FIGURE IIIA-5

0:\0601\12\PERMIT APP\PART III\IIIA-5_SCREENING PLAN.dwg - Necessary

**SAN ANTONIO TRANSFER STATION
BEXAR COUNTY, TEXAS
TCEQ PERMIT NO. MSW-2420
TYPE V PERMIT APPLICATION**

**PART III
SITE PLAN AND DESIGN CRITERIA
APPENDIX IIIB
FACILITY SURFACE WATER DRAINAGE REPORT**

Prepared for

Waste Connections Lone Star, Inc.

January 2024

Revised May 2024

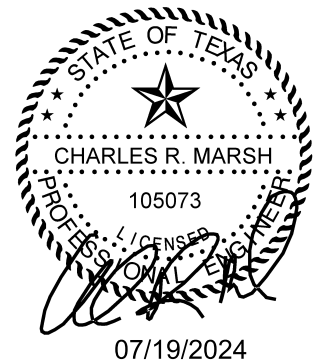

Prepared by

Weaver Consultants Group, LLC

TBPE Registration No. F-3727

6420 Southwest Blvd., Suite 206

Fort Worth, Texas 76109

817-735-9770

WCG Project No. 0601-012-11-01

This document is issued for permitting purposes only.

Tech. Complete App. - 315

CONTENTS

1	INTRODUCTION	IIIB-1
2	STORMWATER MANAGEMENT	IIIB-2
2.1	Regional Drainage Information	IIIB-2
2.2	Surface Water Protection	IIIB-2
2.3	Drainage System Layout	IIIB-3
2.4	TPDES Compliance	IIIB-3
2.5	Erosion and Sedimentation Control Plan	IIIB-4
3	DRAINAGE SYSTEM DESIGN	IIIB-5
3.1	Methodology	IIIB-5
3.2	Hydrologic Analysis	IIIB-5
3.2.1	Description of Computer Program	IIIB-5
3.2.2	Watershed Subareas and Schematization	IIIB-5
3.2.3	Time Step	IIIB-5
3.2.4	Hypothetical Precipitation	IIIB-6
3.2.5	Precipitation Losses	IIIB-6
3.2.6	Hydrograph Information	IIIB-6
4	SITE DRAINAGE PATTERNS	IIIB-8
4.1	Site Drainage Patterns	IIIB-8
4.2	Effect of Site Development on Drainage from the Site	IIIB-8
4.2.1	Peak Flow Rates	IIIB-8
4.2.2	Volumes	IIIB-9
4.2.3	Velocities	IIIB-9
4.2.4	Floodplain	IIIB-9
4.3	Summary	IIIB-10



CONTENTS (Continued)

APPENDIX IIIB-A
Post-Development Condition Drainage Analysis

APPENDIX IIIB-B
Culvert Calculations

APPENDIX IIIB-C
Existing Condition Drainage Analysis

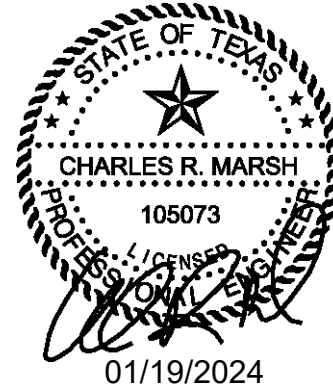

TABLES AND FIGURES

Tables

Page

4-1	Flow Rates, Drainage Areas, Hydrograph Time to Peak Values, Runoff Volumes, and Velocities for the 25-Year Design Storm Event	IIIB-11
-----	---	---------

Figures

4.1	Existing Drainage Conditions
4.2	Post-Development Drainage Conditions
4.3	Existing and Post-Development Drainage Comparison
4.4	Flood Insurance Rate Map
4.5	Pond P1 Plan

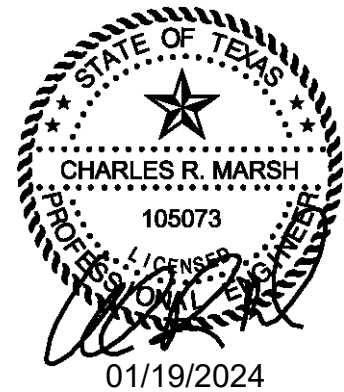

1 INTRODUCTION

This Facility Surface Water Drainage Report is prepared as part of the Municipal Solid Waste (MSW) Type V Permit Application for the San Antonio Transfer Station (TS) consistent with Title 30 Texas Administrative Code (TAC) §330.63(c) and §330.303. This plan addresses surface water drainage design and erosion control. Permit level plans and details are presented for the TS in Appendix IIIA.

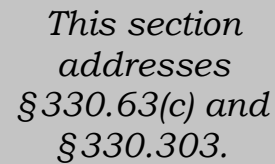

*This section
addresses
§330.63(c) and
§330.303.*

Consistent with Title 30 TAC §330.63(c) and §330.303, the facility will be constructed, maintained, and operated to manage run-on and runoff during the peak discharge of a 25-year, 24-hour rainfall event and will prevent the off-site discharge of waste and in-process and/or processed materials. Surface water drainage in and around a facility shall be controlled to prevent surface water running onto, into, and off the transfer station processing area. Although not specifically required by the rules, the drainage analysis for a 25-year, 24-hour storm event is used to demonstrate that the existing drainage of the TS site will not be adversely altered. The supporting hydrologic demonstrations are included in Appendices IIIB-A and IIIB-C.

As shown on Figure 4.4 and discussed in Parts I/II, Section 11 – Floodplain and Wetlands Statement, no portion of the proposed plan is located within the 100-year floodplain. More importantly, the TS building is not located in the 100-year floodplain, as defined by the Federal Emergency Management Administration (FEMA). No waste storage or processing will occur within the 100-year floodplain.

Section 2 of this report includes a discussion of the regional drainage, stormwater management system, and TPDES compliance. Section 3 discusses the detailed drainage design methodology. Section 4 demonstrates that the TS development will not adversely alter the existing drainage patterns.

2 STORMWATER MANAGEMENT

2.1 Regional Drainage Information

According to the USGS Watershed Boundary Dataset, the San Antonio Transfer Station is located in the Cibolo Creek Watershed (HUC: 12100304). The facility drains to the tributaries of Chupaderes Creek in San Antonio, Texas, which then flows south to Calaveras Lake

2.2 Surface Water Protection

The TS has been designed to achieve the following goals.

1. Prevent a discharge of solid wastes or pollutants adjacent to or into waters of the state.
2. Prevent a discharge of pollutants into waters of the United States.
3. Prevent a discharge of dredged or fill material to waters of the United States.
4. Prevent a discharge of nonpoint source pollution to waters of the United States.
5. Avoid adverse alteration of existing drainage patterns.

The TS facility will consist of a building with a reinforced concrete slab foundation. Drainage from the facility is designed to maintain the existing drainage patterns at the permit boundary and will prevent the offsite discharge of waste and feedstock material, including, but not limited to, in-process and/or processed materials. Surface water drainage in and around the facility will be controlled to prevent surface water running onto, into, and off the processing area. For example:

- Uncontaminated stormwater run-on and runoff will be directed away from the transfer station building entrances by site grading. The inside of the transfer station building will not result in any storm-generated contaminated water since the transfer station building is completely covered. Stormwater

will be managed by maintaining the existing stormwater patterns in areas outside of the transfer station building footprint.

- Runoff from the western and southern areas (designated as offsite drainage areas O1 and O2 in Figures 4-1 and 4-2) predominantly flow in an eastward and northward direction, ultimately converging into the proposed pond denoted as P1. Concurrently, runoff originating from drainage areas DA1, DA2, and DA4 primarily flows eastward, ultimately joining the flow into proposed pond P1. Runoff from drainage area DA3 proceeds in a southerly direction, ultimately connecting with proposed pond P1. Similarly, runoff originating from drainage area DA5 directs eastward into proposed pond P1. Pond P1 efficiently manages all runoff through the spillway and culvert (DP1), which discharge to the east, consistent with existing conditions.
- There is no runoff that enters the Transfer Station building.
- The finish floor elevation for the tipping floor is approximately 645 ft.-msl, which is approximately 54 feet above the nearest 100-year floodplain elevation located approximately ½ mile south. There is no proposed development within the 100-year floodplain.

2.3 Drainage System Layout

The general drainage pattern of the existing TS site is from the west and northwest to the east and southeast. The TS site is located at a topographic high point, generally isolating the site from upland flow.

After the development of the proposed TS is complete, drainage patterns will remain similar to the existing drainage patterns at the TS site. Runoff within the permit boundary is conveyed mainly by sheet flow to discharge locations on the north, west, and east sides of the permit boundary.

2.4 TPDES Compliance

The TS will operate in such a manner as to prevent discharge of pollutants into waters of the state or United States as defined by the Texas Water Code and the Federal Clean Water Act. The site is subject to the TCEQ's stormwater permit requirements and will operate under the TPDES multi-sector General Permit for Stormwater Discharges, under SIC 4212 (Transportation and Warehousing). Construction is subject to the TCEQ's stormwater permit requirements, and a construction stormwater permit will be obtained prior to beginning construction.

Waste Connections Lone Star, Inc. (WCLSI) will maintain a Notice of Intent (NOI) for the San Antonio TS. The facility Stormwater Pollution Prevention Plan (SWPPP) will be developed and implemented prior to operating the improved facility.

2.5 Erosion and Sedimentation Control Plan

Erosion and sedimentation control will be provided, as necessary, during construction activities through the use of a combination of temporary diversion berms and hay bales. These measures will be developed to provide for control of erosion and sediment prior to stormwater flows leaving the site. The temporary erosion control measures will be documented in the SWPPP that will be developed prior to construction of the facilities, consistent with TPDES requirements. Permanent erosion control features have been included in the final site design. These features include the establishment of vegetation or other landscaping on the non-paved portion of the site. In addition, site grading is designed to convey runoff without causing erosion (i.e., runoff velocities are less than 5 ft/sec during a 25-year, 24-hour storm event).

3 DRAINAGE SYSTEM DESIGN

3.1 Methodology

Drainage calculations for the TS are based on the peak flow rates resulting from the 25-year, 24-hour rainfall event for the area. The USACE HEC-HMS computer program was used to compute peak flow rates produced from the design storm. The hydraulic methods employed in this study are consistent with those presented in the TCEQ *Surface Water Drainage Technical Guidance Manual for a Municipal Solid Waste Facility (RG-417, May 2018)*, the 2019 TxDOT *Bridge Division Hydraulic Manual*, and the City of San Antonio *Stormwater Design Criteria Manual*. Manning's n values for culverts, pavement, and vegetated areas were taken from the "Roughness Coefficients (Manning's n) for sheet flow" table 3-1 of *Urban Hydrology for Small Watershed*.

3.2 Hydrologic Analysis

3.2.1 Description of Computer Program

HEC-HMS was used to model the existing and post-development conditions to determine peak flows entering and leaving the TS site. HEC-HMS was developed by the USACE Hydrologic Engineering Center to simulate the surface runoff response of a watershed. The HEC-HMS model represents a watershed as a network of hydrologic and hydraulic components. The modeling process results in the computation of stream-flow hydrographs at desired locations in the watershed.

3.2.2 Watershed Subareas and Schematization

The TS site was delineated to derive a peak flow leaving the TS site. The drainage areas for the post-development and existing conditions are discussed in Appendix IIIB-A and Appendix IIIB-C, respectively.

3.2.3 Time Step

The time step, or the program computation interval, is the time interval that the flow rates for the hydrographs are generated by the program. The time step used for a design storm event is 5 minutes.

3.2.4 Hypothetical Precipitation

The hypothetical precipitation of the storm was obtained from the National Oceanic and Atmospheric Administration (NOAA) Atlas 14 for the project area. For this analysis, the design storm utilized was the 25-year, 24-hour storm event. The precipitation is assumed to be evenly distributed over the TS site for each time interval.

3.2.5 Precipitation Losses

Precipitation losses (the precipitation that does not contribute to the runoff) are calculated using the Soil Conservation Service (SCS) Curve Number (CN) method. CN is a function of soil cover, land use, and antecedent moisture conditions. A CN of 98 was selected to represent the post-development concrete-paved areas at the site, 91 for gravel-surfaced areas, and 74 for natural (existing) ground or vegetated areas. A CN of 100 was used for the low-lying storm water storage areas upstream of the culvert. Further discussion on selection of CN values is provided in Appendices IIIB-A and IIIB-C for post-development and existing conditions.

3.2.6 Hydrograph Information

The Soil Conservation Service (SCS) Unit Hydrograph Method was used for parameter selection in this hydrologic analysis. Reservoir storage-discharge methods were used for hydrograph routings. Information for the model parameters used for this project is included in Appendix IIIB-C (existing) and Appendix IIIB-A (post-development).

SCS Unit Hydrograph Method

The Soil Conservation Service (SCS) Unit Hydrograph Method, also known as the NRCS (Natural Resources Conservation Service) Unit Hydrograph Method, is a widely used hydrological tool for estimating the runoff response of a watershed to a rainfall event. The SCS unit hydrograph method makes use of a dimensionless, curvilinear unit hydrograph to route excess precipitation to the subbasin outlet. The model is based upon averages of Unit Hydrographs derived from gaged rainfall and runoff for a large number of small agricultural watersheds throughout the US. This method is essential for various hydrological and hydraulic engineering applications, including flood forecasting, floodplain management, and the design of water resource and soil conservation structures.

Hydrograph Routing

The hydrograph at the post-development Pond P1 outlet was generated by routing the inflow through the available volume for the pond storage. Additionally, the physical characteristics of the spillway were incorporated to generate a compound discharge of spillway and culvert flow.

4 SITE DRAINAGE PATTERNS

This section provides a demonstration that the TS development will not adversely alter the existing drainage patterns. A summary of drainage patterns and stormwater flows produced by the 25-year, 24-hour storm event are presented on the following Appendices.

- Appendix IIIB-A – Post-development Condition Hydrologic Calculations
- Appendix IIIB-C – Existing Condition Hydrologic Calculations

The following two sections discuss: (1) site drainage patterns and (2) the effect of the proposed development on peak flows, volumes, and velocities discharged from the site.

4.1 Site Drainage Patterns

The post-development drainage patterns are consistent with the existing drainage patterns. Runoff exits the permit boundary in both analyzed conditions from discharge location DP1. The total drainage area to the discharge location DP1 is the same for the existing and post-development conditions.

Runoff exiting the permit boundary on the east (DP1) side discharge via sheetflow flow across the permit boundary. This runoff ultimately flows into existing tributaries of Chupaderas Creek, which then flows southward to Calaveras Lake.

4.2 Effect of Site Development on Drainage from the Site

4.2.1 Peak Flow Rates

As shown on Table 4-1, the comparison of existing and post-development drainage conditions at the site shows that the peak flows generated by a 25-year storm event and discharging off the permit boundary of the site are not adversely altered by the proposed TS development. Additionally, the TS site design will not change the direction at which stormwater runoff leaves the site. Drainage analyses

for post-development conditions and existing conditions at the site are presented in Appendices IIIB-C and IIIB-A, respectively.

Stormwater exiting the permit boundary discharges at one main location, eastward (DP1). The proposed plan for the construction of the Transfer Station site includes adding paved areas and construction of the transfer station building and other required improvements do not adversely affect the peak flow at discharge location DP1. The design of proposed pond P1 ensures that all water flow is directed towards discharge point DP1 through its spillway and culvert. All the proposed paved areas around the transfer station building direct their flow into the proposed pond P1. It's worth noting that the transfer station building will be situated at an elevation of 645 ft-msl, which is 4.6 ft higher than the peak elevation within Pond P1 expected during a 25-Year design storm.

4.2.2 Volumes

Post-development runoff volume generated at discharge point DP1 is slightly increased due to adding more paved areas compared to the existing condition (13.50 ac-ft versus 11.63 ac-ft). Runoff volume from offsite drainage area O1 to the permit boundary is same at the post-development condition compared to the existing condition (0.7 ac-ft). Runoff volume from offsite drainage area O2 to the permit boundary in the post-development condition slightly increased compared to existing condition (7.69 ac-ft versus 7.43 ac-ft). This increase is attributed to more paved areas in the post-development plan.

Runoff volume calculations are provided in Appendices IIIB-A and IIIB-C. As shown on Table 4-1, the maximum increase in runoff volume for discharge point DP1 is 1.87 acre-feet. However, the increased volume is discharged at the lower peak flow rate when compared to the existing condition. Therefore, this increase in volume is not an adverse alteration.

4.2.3 Velocities

A summary of the 25-year frequency storm peak flow velocities that enter and exit the site are shown on Table 4-1 and Figure 4-3. Flow velocities at all locations are approximately same. At DP1, the flow velocity decreases by 0.05 ft/sec compared to existing conditions. Velocity calculations are provided in Appendices IIIB-A and IIIB-C for the post-development and existing conditions, respectively.

4.2.4 Floodplain

As discussed in Section 11 of Parts I/II, no portion of the site is located within the 100-year floodplain. The effective FIRM is shown on Figure 4-4.

4.3 Summary

From the hydrological evaluations of the existing and post-development conditions, the existing drainage conditions at the permit boundary will not be adversely altered by the proposed development. Given that: (1) drainage patterns are not adversely altered, (2) the post-development peak discharge rate compared to the existing condition is lower at the permit boundary, (3) total volume of stormwater leaving the permit boundary is not adversely impacted for the existing and post-development conditions, (4) there is no increase in velocity at the discharge point from the permit boundary, (5) the stormwater discharge location is consistent with the existing configuration, and (6) the floodplain is not impacted, it is concluded that the proposed development will not adversely alter existing drainage patterns.

0:\0601\12\PERMIT APP\PART III\CLEAN\FIG 4-1 Permitted Drainage Conditions.dwg, mbahmani, 1:2

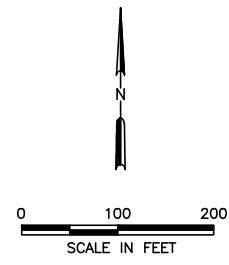
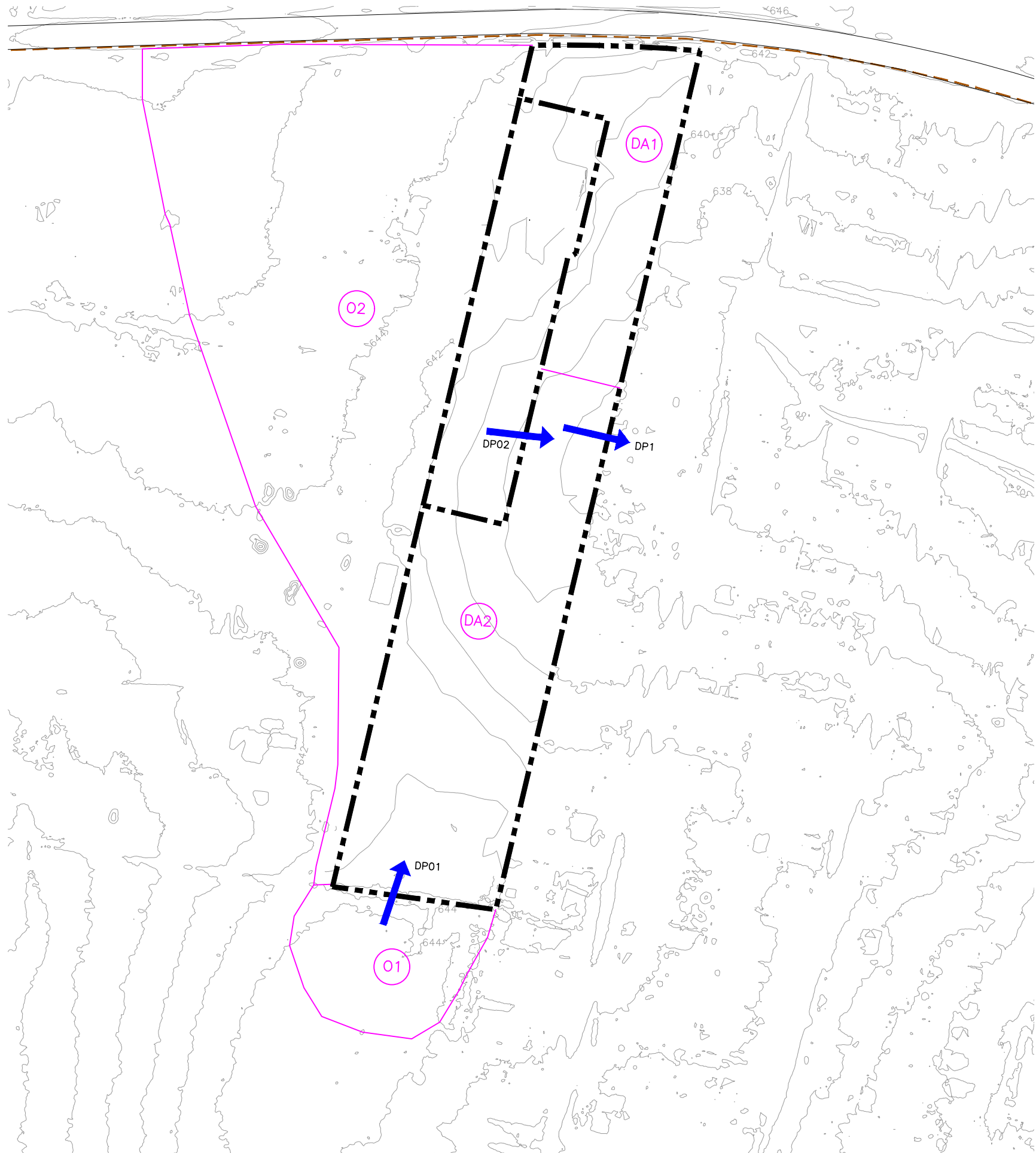

LEGEND

- PERMIT BOUNDARY
- PROPERTY BOUNDARY
- 430 EXISTING CONTOUR
- SEWER LINE
- FLOW LINE
- DRAINAGE AREA
- ➔ DISCHARGE LOCATIONS
- DA1 DRAINAGE AREA DESIGNATION

NOTES:
 1. THE EXISTING CONTOURS PROVIDED BY TEXAS RESOURCE INFORMATION SYSTEM (TNRIS) BEXAR AND TRAVIS COUNTIES LIDAR, 2022.

EXISTING CONDITION DRAINAGE AREAS	
DRAINAGE AREA	AREA (ACRES)
O1	1.58
O2	13.40
DA1	2.22
DA2	5.29

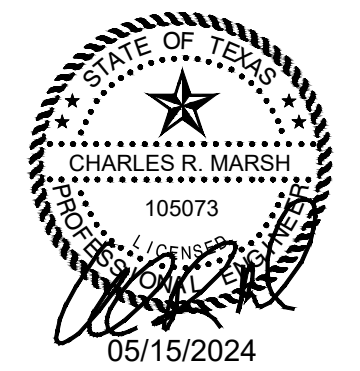

Tech. Complete App. - 329

<input type="checkbox"/> 90% REVIEW <input checked="" type="checkbox"/> FOR PERMITTING PURPOSES ONLY <input type="checkbox"/> ISSUED FOR CONSTRUCTION	PREPARED FOR WASTE CONNECTIONS LONE STAR, INC.	TYPE V PERMIT APPLICATION EXISTING DRAINAGE CONDITIONS SAN ANTONIO TRANSFER STATION BEXAR COUNTY, TEXAS						
	DATE: 01/2024 FILE: 0601-012-11 CAD: FIGURE 4-1 PERMITTED DRNG CON.DWG		DRAWN BY: RAA DESIGN BY: MB REVIEWED BY: CRM					
Weaver Consultants Group TBPE REGISTRATION NO. F-3727		REVISIONS <table border="1"> <thead> <tr> <th>NO.</th> <th>DATE</th> <th>DESCRIPTION</th> </tr> </thead> <tbody> <tr> <td>1</td> <td>05/2024</td> <td>PERMIT MODIFICATION</td> </tr> </tbody> </table>	NO.	DATE	DESCRIPTION	1	05/2024	PERMIT MODIFICATION
NO.	DATE	DESCRIPTION						
1	05/2024	PERMIT MODIFICATION						
		WWW.WCGRP.COM FIGURE 4-1						

0:\0601\12\TYPE V PERMIT APP\PART III\CLEAN\FIG 4-3 DRAINAGE COMPARISON.dwg, m.bahmani, 1:2

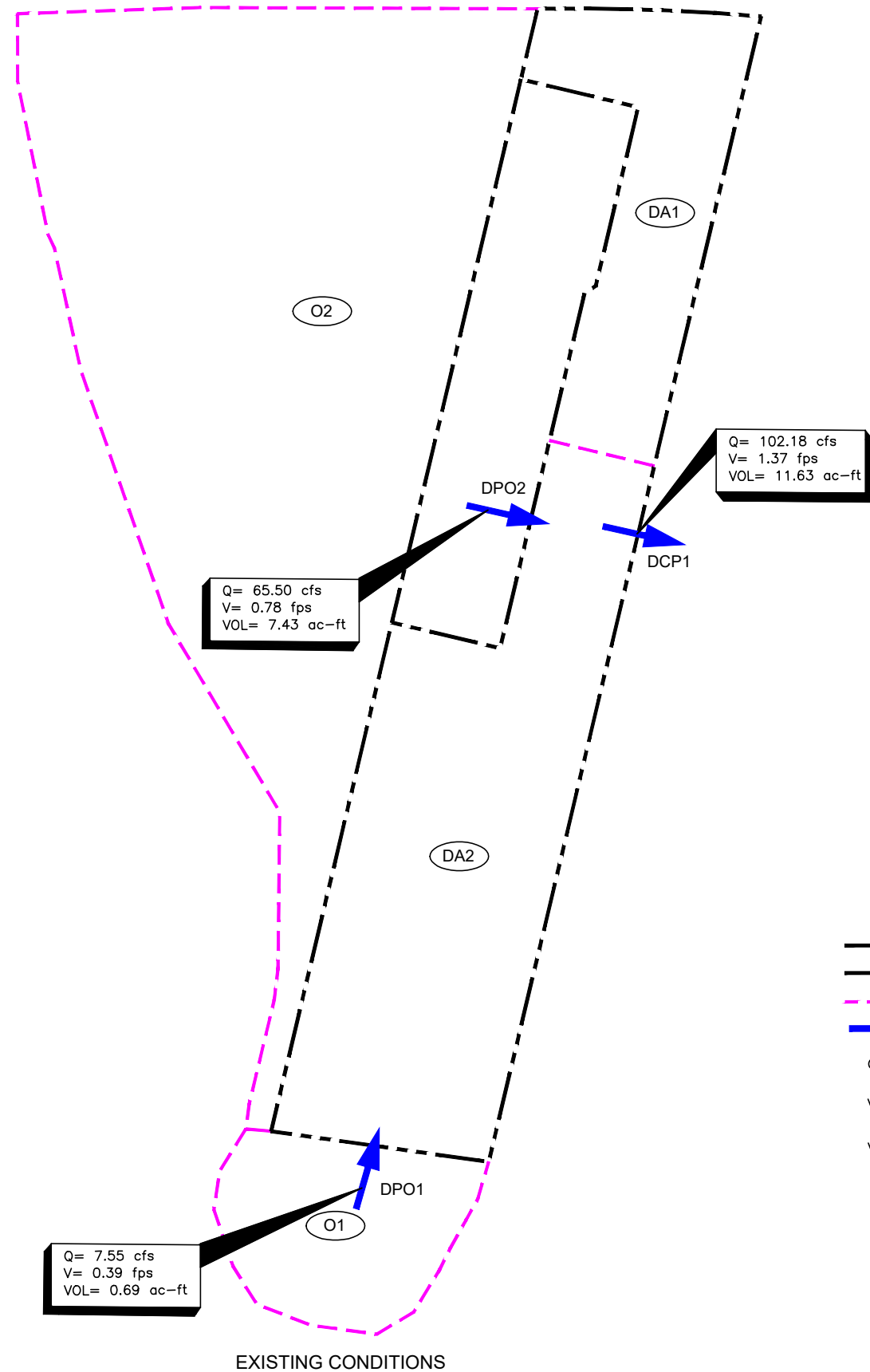

EXISTING CONDITIONS

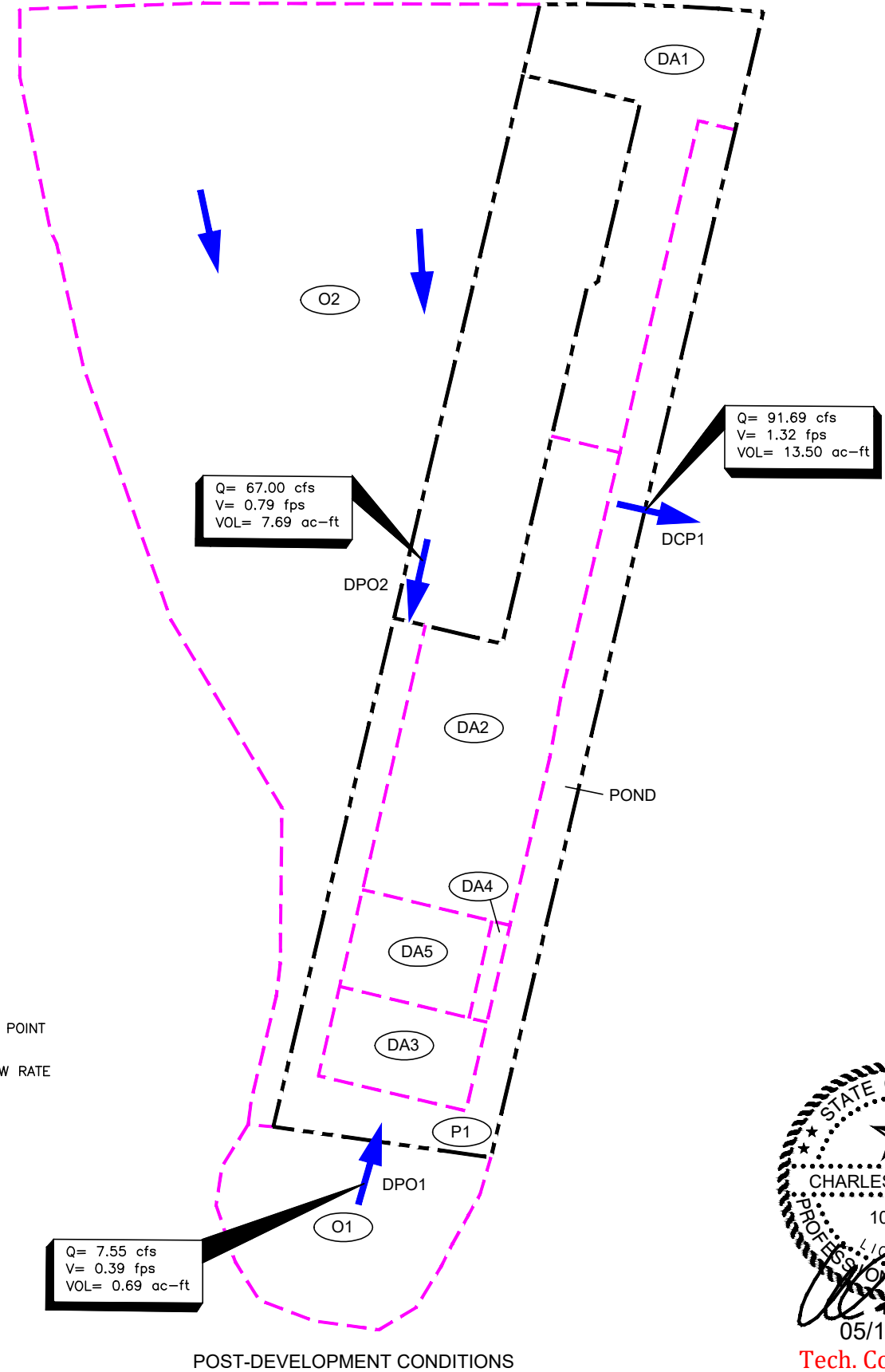

POST-DEVELOPMENT CONDITIONS

N

0 100 200
SCALE IN FEET

LEGEND

	PROPERTY BOUNDARY
	PERMIT BOUNDARY
	DRAINAGE BOUNDARY
	DCP1 STORMWATER DISCHARGE POINT
	Q= 11.00 cfs 25-YEAR 24-HOUR STORM EVENT PEAK FLOW RATE
	V= 3.39 fps 25-YEAR 24-HOUR FLOW VELOCITY
	VOL= 2.80 ac-ft 25-YEAR 24-HOUR FLOW VOLUME

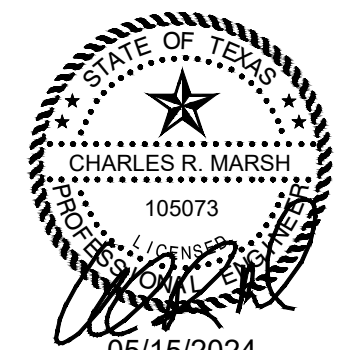

05/15/2024

Tech. Complete App. - 331

NOTE:
1. THE PROPERTY BOUNDARY AND PERMIT BOUNDARY ARE REPRODUCED FROM A LEGAL DESCRIPTION PROVIDED BY TEXAS RESOURCE INFORMATION SYSTEM (TNRIS) BEXAR AND TRAVIS COUNTIES LIDAR, 2022.

<input type="checkbox"/> DRAFT <input checked="" type="checkbox"/> FOR PERMITTING PURPOSES ONLY <input type="checkbox"/> ISSUED FOR CONSTRUCTION	PREPARED FOR WASTE CONNECTIONS LONE STAR, INC.		TYPE V PERMIT APPLICATION EXISTING AND POST-DEVELOPMENT DRAINAGE COMPARISON SAN ANTONIO TRANSFER STATION BEXAR COUNTY, TEXAS					
	DATE: 01/2024 FILE: 0601-012-11 CAD: FIG 4-3 DRAINAGE COMPARISON.DWG	DRAWN BY: RAA DESIGN BY: MB REVIEWED BY: CRM		REVISIONS <table border="1" style="width: 100%; border-collapse: collapse;"> <thead> <tr> <th style="width: 5%;">NO.</th> <th style="width: 15%;">DATE</th> <th style="width: 80%;">DESCRIPTION</th> </tr> </thead> <tbody> <tr> <td style="text-align: center;">1</td> <td style="text-align: center;">05/2024</td> <td style="text-align: center;">PERMIT MODIFICATION</td> </tr> </tbody> </table>	NO.	DATE	DESCRIPTION	1
NO.	DATE	DESCRIPTION						
1	05/2024	PERMIT MODIFICATION						
Weaver Consultants Group TBPE REGISTRATION NO. F-3727		WWW.WCGRP.COM	FIGURE 4-3					



APPROXIMATE LOCATION OF SAN ANTONIO TRANSFER STATION

CHUPADERAS CREEK TRIBUTARIES

AREA OF MINIMAL FLOOD HAZARD

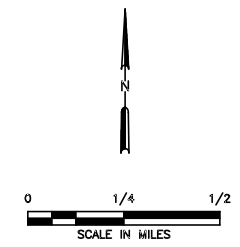

LEGEND

-----	PERMIT BOUNDARY
-----	PROPERTY BOUNDARY
SPECIAL FLOOD HAZARD AREAS	
[Light Blue]	Without Base Flood Elevation (BFE) Zone A, V, A99
[Light Blue]	With BFE or Depth Zone AE, A0, AH, VE, AR
[Red Hatched]	Regulatory Floodway
OTHER AREAS OF FLOOD HAZARD	
[Orange]	0.2% Annual Chance Flood Hazard, Areas of 1% annual chance flood with average depth less than one foot or with drainage areas of less than one square mile Zone X
[Grey Hatched]	Future Conditions 1% Annual Chance Flood Hazard Zone X
[Diagonal Hatched]	Area with Reduced Flood Risk due to Levee See Notes Zone X
[Yellow Hatched]	Area with Flood Risk due to Levee Zone D
OTHER AREAS	
[White]	NO SCREEN Area of Minimal Flood Hazard Zone X
[Blue]	Effective LOMRs
[Light Orange]	Area of Undetermined Flood Hazard Zone D
GENERAL STRUCTURES	
[Dashed Line]	Channel, Culvert, or Storm Sewer
[Dotted Line]	Levee, Dike, or Floodwall
OTHER FEATURES	
[Circle with 20.2]	20.2 Cross Sections with 1% Annual Chance Water Surface Elevation
[Circle with 17.5]	17.5 Cross Sections with 1% Annual Chance Water Surface Elevation
[Circle with S]	Coastal Transect
[Dashed Line]	Coastal Transect Baseline
[Dotted Line]	Profile Baseline
[Blue Line]	Hydrographic Feature
[Wavy Line]	Base Flood Elevation Line (BFE)
[Red Line]	Limit of Study
[Yellow Line]	Jurisdiction Boundary

NOTES:

- FLOODPLAIN INFORMATION PROVIDED BY FEMA FIRM PANEL 48029C0445G FOR BEXAR COUNTY, TEXAS AND INCORPORATED AREAS DATED SEPTEMBER 29, 2010.



Tech. Complete App. - 332

<input type="checkbox"/> DRAFT <input checked="" type="checkbox"/> FOR PERMITTING PURPOSES ONLY <input type="checkbox"/> ISSUED FOR CONSTRUCTION		PREPARED FOR WASTE CONNECTIONS LONE STAR, INC.		TYPE V PERMIT APPLICATION FLOOD INSURANCE RATE MAP SAN ANTONIO TRANSFER STATION BEXAR COUNTY, TEXAS	
DATE: 01/2024 FILE: 0601-012-11 CAD: FIG 4-4-FIRM.DWG		DRAWN BY: RAA DESIGN BY: MB REVIEWED BY: CRM			
		REVISIONS			
		NO.	DATE	DESCRIPTION	
		1	05/2024	PERMIT MODIFICATION	
Weaver Consultants Group TBE REGISTRATION NO. F-3727		WWW.WCGRP.COM		FIGURE 4-4	

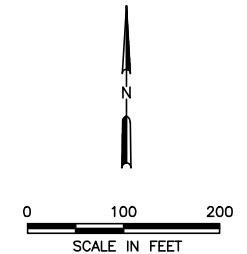
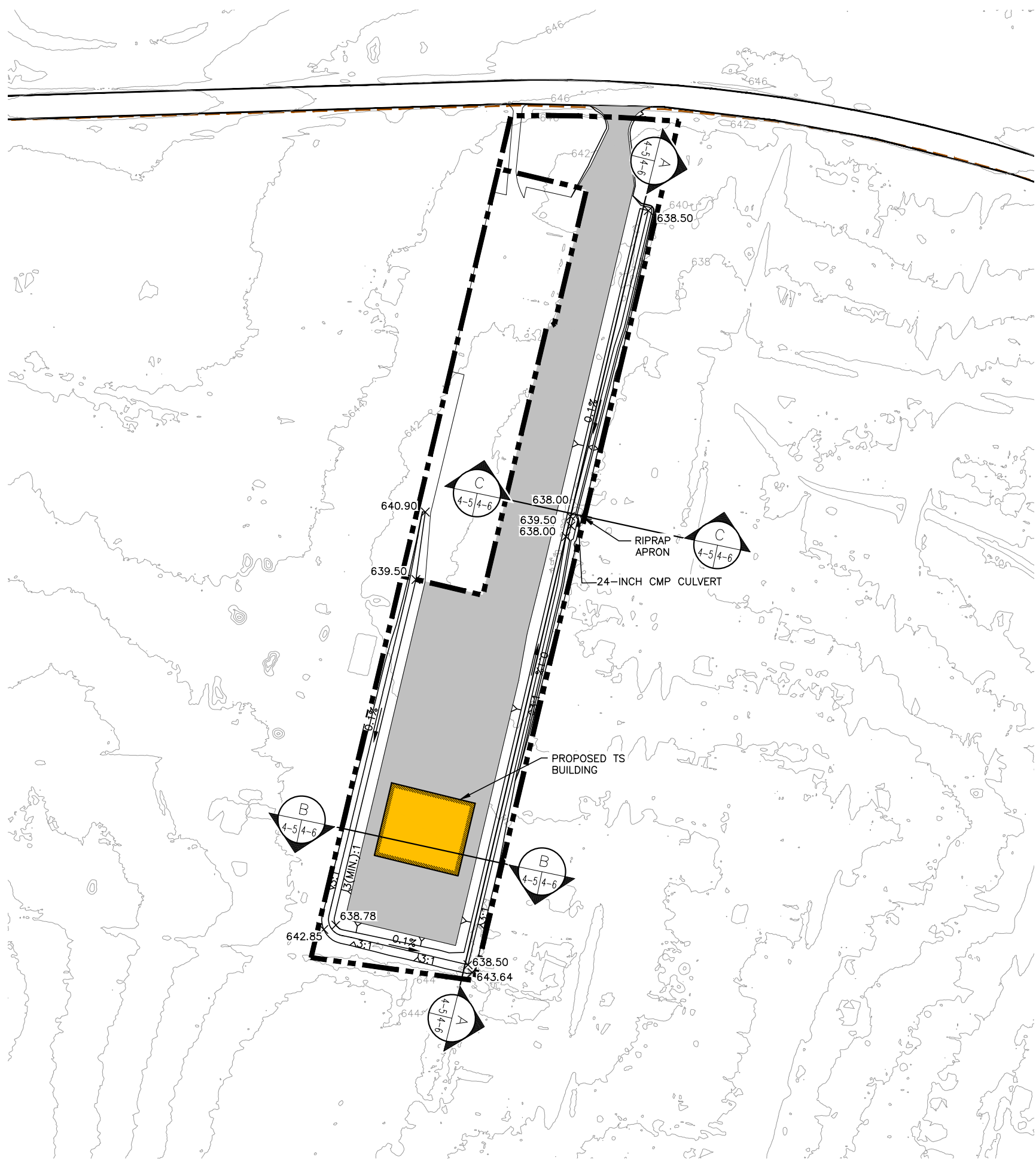

LEGEND

	PERMIT BOUNDARY
	PROPERTY BOUNDARY
	EXISTING CONTOUR

- NOTES:
- THE EXISTING CONTOURS PROVIDED BY TEXAS RESOURCE INFORMATION SYSTEM (TNRIS) BEXAR AND TRAVIS COUNTIES LIDAR, 2022.

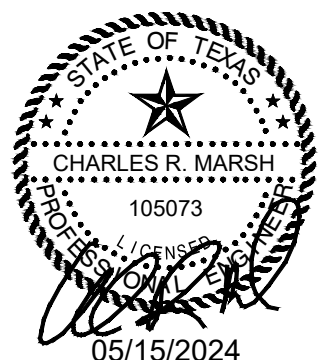

Tech. Complete App. - 333

<input type="checkbox"/> 90% REVIEW <input checked="" type="checkbox"/> FOR PERMITTING PURPOSES ONLY <input type="checkbox"/> ISSUED FOR CONSTRUCTION	PREPARED FOR		TYPE V PERMIT APPLICATION POND 1 PLAN SAN ANTONIO TRANSFER STATION BEXAR COUNTY, TEXAS
	WASTE CONNECTIONS LONE STAR, INC.		
DATE: 01/2024 FILE: 0601-012-11 CAD: FIG-4-5 POND PLAN.DWG	DRAWN BY: RAA DESIGN BY: MB REVIEWED BY: CRM	REVISIONS	
Weaver Consultants Group TBPE REGISTRATION NO. F-3727		NO. 1 DATE 05/2024 DESCRIPTION PERMIT MODIFICATION	WWW.WCGRP.COM FIGURE 4-5

O:\0601\12\TYPE V PERMIT APP\PART III\CLEAN\FIG 4-5 Pond Plan.dwg, cmarsh, 1/2

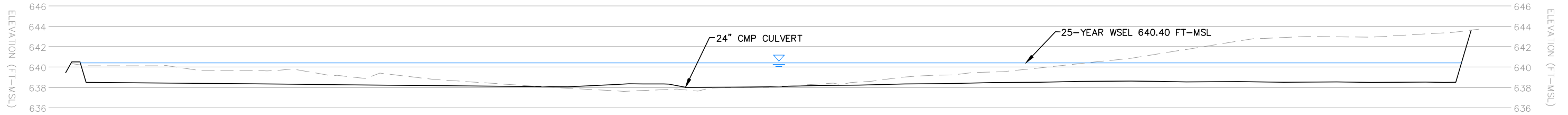

DETENTION POND P1 SECTION A
 0 50 100
 HORIZONTAL SCALE IN FEET
 0 5 10
 VERTICAL SCALE IN FEET

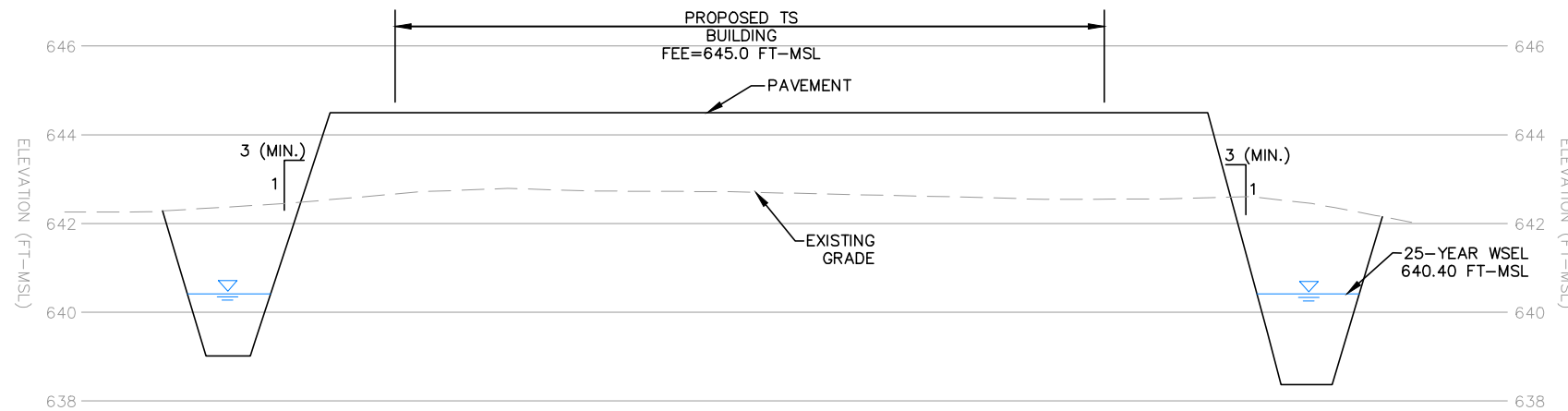

DETENTION POND P1 SECTION B
 0 20 40
 HORIZONTAL SCALE IN FEET
 0 2 4
 VERTICAL SCALE IN FEET

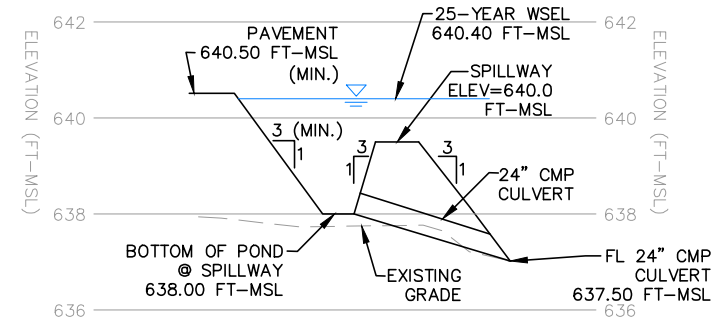

DETENTION POND P1 SECTION C
 SPILLWAY LOCATION
 0 20 40
 HORIZONTAL SCALE IN FEET
 0 2 4
 VERTICAL SCALE IN FEET

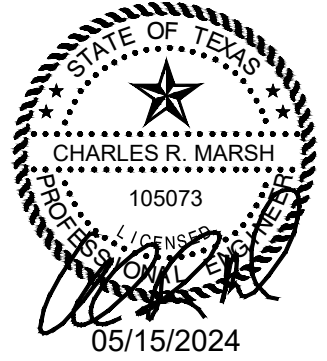

Tech. Complete App. - 334

<input type="checkbox"/> 90% REVIEW <input checked="" type="checkbox"/> FOR PERMITTING PURPOSES ONLY <input type="checkbox"/> ISSUED FOR CONSTRUCTION	PREPARED FOR WASTE CONNECTIONS LONE STAR, INC.		TYPE V PERMIT APPLICATION POND SECTIONS	
	DATE: 01/2024 FILE: 0601-012-11 CAD: FIG-4-6 POND SECTIONS.DWG		DRAWN BY: RAA DESIGN BY: MB REVIEWED BY: CRM	
REVISIONS		SAN ANTONIO TRANSFER STATION BEXAR COUNTY, TEXAS		
		NO.	DATE	DESCRIPTION
		1	05/2024	PERMIT MODIFICATION
Weaver Consultants Group TBPE REGISTRATION NO. F-3727		WWW.WCGRP.COM		FIGURE 4-6

**Table 4-1
Flow Rates, Drainage Areas, Hydrograph Time to Peak Values, Runoff Volumes, and Velocities
for the 25-Year Design Storm Event**

Stormwater Discharge Point ¹	Existing Conditions				Post-development Conditions			
	Flow Rate (cfs)	Drainage Area (acres)	Runoff Volume (ac-ft)	Velocity at Permit Boundary ² (ft/sec)	Flow Rate (cfs)	Drainage Area (acres)	Runoff Volume (ac-ft)	Velocity at Permit Boundary ² (ft/sec)
DP1	102.18	22.49	11.63	1.37	91.69	22.49	13.50	1.32
DP01	7.55	1.58	0.69	0.39	7.55	1.58	0.69	0.39
DP02	65.50	13.40	7.43	0.78	67.00	13.40	7.69	0.79

¹ Stormwater discharge points are shown on Figure 4-3. The volume shown is the total volume of runoff for the hydrograph duration.

² Runoff volume and velocity calculations are provided in Appendix IIIB-A and IIIB-C.

³ Discharges onto access road owned by Permittee.

APPENDIX IIIB-A

POST-DEVELOPMENT CONDITION DRAINAGE ANALYSIS

Includes pages IIIB-A-1 through IIIB-A-45

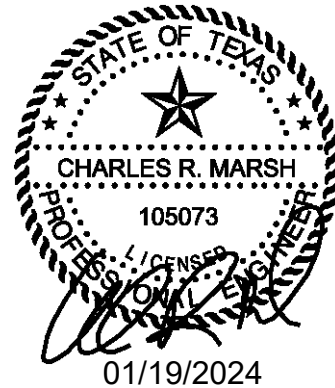

CONTENTS

Hypothetical Storm Data	IIIB-A-1
Precipitation Loss Data	IIIB-A-3
Hydrograph Development Information	IIIB-A-9
Post-Development HEC-HMS Analysis Drainage Areas	IIIB-A-15
HEC-HMS Output – Post-development 25-Year, 24-Hour Storm Event	IIIB-A-17
Volume Calculations	IIIB-A-41
Velocity Calculations	IIIB-A-44



HYPOTHETICAL STORM DATA

Hypothetical Storm Data

Precipitation data taken from NOAA Atlas 14, Volume 11, Version 2.

Time	5 min	15 min	60 min	2 hr	3 hr	6 hr	12 hr	24 hr
25 Year Event	0.907	1.8	3.34	4.39	5.07	6.22	7.24	8.29

PRECIPITATION LOSS DATA

Required: Determine the SCS curve numbers for the on-site drainage areas and pond for use in the HEC-HMS analysis.

- References:**
1. HEC-HMS, U.S. Army Corps of Engineers, Institute For Water Resources, Hydrologic Engineering Center.
 2. United States Department of Agriculture, National Resource Conservation Service, Web Soil Survey for Collin County, Texas (<http://websoilsurvey.nrcs.usda.gov>).

Solution: Based on the soil survey information found in Ref. 2, hydrologic group C soils predominate the soils within the permit boundary drainage area (see pages IIIB-A-5 through IIIB-A-7).

The non-impervious portions of subbasins (e.g., non-paved areas) were considered to be open space, contoured and in good condition. A curve number was selected using the provided drainage manual and the Web Soil Survey.

Use: CN = 74

The curve number for the proposed impervious, concrete-paved areas was selected using the provided drainage manual and the Web Soil Survey.

Use: CN = 98

The pond area is assumed to consist of areas that have zero precipitation losses (water surfaces) with vegetated sideslopes and gravel-surfaced top of embankment areas

Use: CN = 99

Hydrologic Soil Group—Bexar County, Texas



Soil Map may not be valid at this scale.

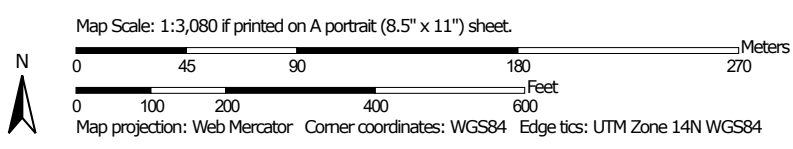

MAP LEGEND

Area of Interest (AOI)









 Area of Interest (AOI)

Soils

Soil Rating Polygons





-  A
-  A/D
-  B
-  B/D
-  C
-  C/D
-  D
-  Not rated or not available

Soil Rating Lines

-  A
-  A/D
-  B
-  B/D
-  C
-  C/D
-  D
-  Not rated or not available

Soil Rating Points





-  A
-  A/D
-  B
-  B/D

-  C
-  C/D
-  D
-  Not rated or not available

Water Features

 Streams and Canals

Transportation

-  Rails
-  Interstate Highways
-  US Routes
-  Major Roads
-  Local Roads

Background

 Aerial Photography

MAP INFORMATION

The soil surveys that comprise your AOI were mapped at 1:24,000.

Warning: Soil Map may not be valid at this scale.

Enlargement of maps beyond the scale of mapping can cause misunderstanding of the detail of mapping and accuracy of soil line placement. The maps do not show the small areas of contrasting soils that could have been shown at a more detailed scale.

Please rely on the bar scale on each map sheet for map measurements.

Source of Map: Natural Resources Conservation Service
 Web Soil Survey URL:
 Coordinate System: Web Mercator (EPSG:3857)

Maps from the Web Soil Survey are based on the Web Mercator projection, which preserves direction and shape but distorts distance and area. A projection that preserves area, such as the Albers equal-area conic projection, should be used if more accurate calculations of distance or area are required.

This product is generated from the USDA-NRCS certified data as of the version date(s) listed below.

Soil Survey Area: Bexar County, Texas
 Survey Area Data: Version 26, Aug 24, 2022

Soil map units are labeled (as space allows) for map scales 1:50,000 or larger.

Date(s) aerial images were photographed: Dec 3, 2020—Dec 9, 2020

The orthophoto or other base map on which the soil lines were compiled and digitized probably differs from the background imagery displayed on these maps. As a result, some minor shifting of map unit boundaries may be evident.

Hydrologic Soil Group

Map unit symbol	Map unit name	Rating	Acres in AOI	Percent of AOI
OrB	Laparita clay loam, 1 to 3 percent slopes	C	3.0	15.2%
SaB	San Antonio clay loam, 1 to 3 percent slopes	C	16.4	84.8%
Totals for Area of Interest			19.4	100.0%

Description

Hydrologic soil groups are based on estimates of runoff potential. Soils are assigned to one of four groups according to the rate of water infiltration when the soils are not protected by vegetation, are thoroughly wet, and receive precipitation from long-duration storms.

The soils in the United States are assigned to four groups (A, B, C, and D) and three dual classes (A/D, B/D, and C/D). The groups are defined as follows:

Group A. Soils having a high infiltration rate (low runoff potential) when thoroughly wet. These consist mainly of deep, well drained to excessively drained sands or gravelly sands. These soils have a high rate of water transmission.

Group B. Soils having a moderate infiltration rate when thoroughly wet. These consist chiefly of moderately deep or deep, moderately well drained or well drained soils that have moderately fine texture to moderately coarse texture. These soils have a moderate rate of water transmission.

Group C. Soils having a slow infiltration rate when thoroughly wet. These consist chiefly of soils having a layer that impedes the downward movement of water or soils of moderately fine texture or fine texture. These soils have a slow rate of water transmission.

Group D. Soils having a very slow infiltration rate (high runoff potential) when thoroughly wet. These consist chiefly of clays that have a high shrink-swell potential, soils that have a high water table, soils that have a claypan or clay layer at or near the surface, and soils that are shallow over nearly impervious material. These soils have a very slow rate of water transmission.

If a soil is assigned to a dual hydrologic group (A/D, B/D, or C/D), the first letter is for drained areas and the second is for undrained areas. Only the soils that in their natural condition are in group D are assigned to dual classes.

Rating Options

Aggregation Method: Dominant Condition

"Straight row" and the hydrologic condition is "Good", then the SCS Curve Numbers will range from 67 to 89, depending on the soil group.

Land Use Description	Hydrologic Soil Group			
	A	B	C	D
Residential:				
1/8 acre or less average lots (65% imperv.)	77	85	90	92
1/4 acre average lots (38% impervious)	61	75	83	87
1/3 acre average lots (35% impervious)	57	72	81	86
1/2 acre average lots (25% impervious)	54	70	80	85
1 acre average lots (20% impervious)	51	68	79	84
Paved parking lots, roofs, driveways, etc.	98	98	98	98
Streets and Roads:				
Paved with curbs and storm sewers	98	98	98	98
gravel	76	85	89	91
dirt	72	82	87	89
Commercial & Business Areas (85% Impervious)	89	92	94	95
Industrial Districts (72% Impervious)	81	88	91	93
Open Spaces, Lawns, Parks, Golf Courses, Cemeteries, etc.:				
good condition grass cover on 75% or more	39	61	74	80
fair condition grass cover on 50% to 75%	49	69	79	84

TABLE 5.2 Values of SCS Curve Number for Urban and Suburban Areas

Source: [McCuen, 1982].

The values in this table are "adjusted" to account for the effects of urbanization. These adjusted values already account for the effects of impervious cover in the watershed. Therefore, the "Percent Impervious Cover in Watershed" value should normally be set to zero (0) if the adjusted Curve Numbers listed in this table are used.

This is **not** the method recommended for use in HEC-1.

HYDROGRAPH DEVELOPMENT INFORMATION

HYDROGRAPH DEVELOPMENT INFORMATION

Offsite and Overland Flow Areas

The hydrographs for the drainage areas were developed using the Soil Conservation Service (SCS) unit hydrograph method. The National Resources Conservation Service (NRCS) method has been used to estimate Snyder parameters. SCS parameter estimations are provided on pages IIIB-A-11 through IIIB-A-14.

Drainage Areas

The drainage areas used for this analysis are shown on Sheet IIIB-A-16. The routing scheme is shown in the HEC-HMS output file.

SAN ANTONIO TRANSFER STATION
0601-012-11
SCS UNIT HYDROGRAPH DATA

SCS Unit Hydrograph Coefficients (NRCS Method)

Proposed Conditions

Drainage Area	Area (acres)	I (%)	Manning "n"	CN	Sheet Flow				Shallow Concentrated Flow				t _{total} min	t _{lag} min	
					Length ft	P ₂ in	Slope	t _{sheet} hr	Paved?	Length ft	Slope	Velocity ft/sec			t _{shallow} hr
DA1	1.71	65	0.01	90	300	4.44	0.0100	0.083	Y	84	0.0100	2.0328	0.011	5.7	3.4
DA2	2.19	100	0.01	98	300	4.44	0.0060	0.083	Y	56	0.0120	2.2268	0.007	5.4	3.3
DA3	0.54	100	0.01	98	119	4.44	0.0100	0.083	Y	--	--	--	--	5.0	3.0
DA4	0.07	100	0.01	98	24	4.44	0.0230	0.083	Y	--	--	--	--	5.0	3.0
DA5	0.52	100	0.01	98	174	4.44	0.0200	0.083	Y	--	--	--	--	5.0	3.0
O1	1.58	2	0.15	74	250	4.44	0.0040	0.333	N	--	--	--	--	20.0	12.0
O2	13.40	35	0.15	85	300	4.44	0.0133	0.333	N	606	0.0080	1.4431	0.117	27.0	16.2
P1	2.50	0	--	99	--	--	--	--	--	--	--	--	--	--	0.1

- t_r = surface runoff to unit hydrograph peak (min)
- I = impervious cover within the watershed (%)
- t_{lag} = watershed lag time (min)
- P₂ = 2-year, 24-hour rainfall depth (in)
- t_{sheet} = Time for the sheet flow (Initial 300 ft of the flow length) (Per "San Antonio Storm Water Drainage Manual", maximum overland flow is 20 min and its minimum is 5 min)
- t_{shallow} = Time for the shallow concentrated flow (flow length after initial 300 ft)

SCS Unit Hydrograph uses lag time (t_{lag}) for flood wave and watershed storage conditions.

Dainage area DA1 is used for example.

Estimated Watershed specific parameters

A =	1.71	acres	watershed area
L =	384.00	feet	maximun flow length with this watershed
S =	0.01	feet/feet	watershed slope
I =	65	percent (%)	watershed imperviousness
n =	0.01		Manning's coefficient
P ₂ =	4.44	in	2-Year, 24-Hour rainfall depth

The SCS UH lag can be estimated via calibration for gaged headwater subwatersheds. Time of concentration is a quasi-physically based parameter that can be estimated as:

$$t_{total} = t_{sheet} + t_{shallow} + t_{channel}$$

Calculate T_{sheet} : Sum of travel time in sheet flow segments over the watershed land surface

$$t_{sheet} = 0.007(nL)^{0.8} / (P_2^{0.5} S^{0.4})$$

$$t_{sheet} = 0.007(0.01 * 300)^{0.8} / ((4.44^{0.5})(0.01^{0.4}))$$

$$t_{sheet} = 0.054 \quad \text{hr}$$

$$t_{sheet} = 5.0 \quad \text{min} \quad (\text{Per "San Antonio Storm Water Srainage Manual", maximum overland flow is 20 min and its minimum is 5 min})$$

Calculate $t_{shallow}$: Sum of travel time in shallow flow segments, down streets, in gutters, or in shallow rills and rivulets

$$t_{shallow} = L/V \quad (V \text{ is flow veloicity})$$

$$V = 16.1345(S^{0.5}) \quad \text{Flow velocity for unpaved surface}$$

$$V = 20.3282(S^{0.5}) \quad \text{Flow velocity for paved surface}$$

DA1 is a paved surface.

$$t_{shallow} = 84 / (3600 * 20.3282(0.01^{0.5}))$$

$$t_{shallow} = 0.011 \quad \text{hr}$$

$$t_{shallow} = 0.7 \quad \text{min}$$

Calculate $T_{channel}$: Sum of travel time in channel segments.

There is no channel flow in this drainage area.

$$t_{total} = 5.7 \quad \text{min}$$

$$t_{lag} = 0.6 t_{total}$$

$$t_{lag} = 3.4 \quad \text{min}$$

Chapter 3

Time of Concentration and Travel Time

Travel time (T_t) is the time it takes water to travel from one location to another in a watershed. T_t is a component of time of concentration (T_c), which is the time for runoff to travel from the hydraulically most distant point of the watershed to a point of interest within the watershed. T_c is computed by summing all the travel times for consecutive components of the drainage conveyance system.

T_c influences the shape and peak of the runoff hydrograph. Urbanization usually decreases T_c , thereby increasing the peak discharge. But T_c can be increased as a result of (a) ponding behind small or inadequate drainage systems, including storm drain inlets and road culverts, or (b) reduction of land slope through grading.

Factors affecting time of concentration and travel time

Surface roughness

One of the most significant effects of urban development on flow velocity is less retardance to flow. That is, undeveloped areas with very slow and shallow overland flow through vegetation become modified by urban development: the flow is then delivered to streets, gutters, and storm sewers that transport runoff downstream more rapidly. Travel time through the watershed is generally decreased.

Channel shape and flow patterns

In small non-urban watersheds, much of the travel time results from overland flow in upstream areas. Typically, urbanization reduces overland flow lengths by conveying storm runoff into a channel as soon as possible. Since channel designs have efficient hydraulic characteristics, runoff flow velocity increases and travel time decreases.

Slope

Slopes may be increased or decreased by urbanization, depending on the extent of site grading or the extent to which storm sewers and street ditches are used in the design of the water management system. Slope will tend to increase when channels are straightened and decrease when overland flow is directed through storm sewers, street gutters, and diversions.

Computation of travel time and time of concentration

Water moves through a watershed as sheet flow, shallow concentrated flow, open channel flow, or some combination of these. The type that occurs is a function of the conveyance system and is best determined by field inspection.

Travel time (T_t) is the ratio of flow length to flow velocity:

$$T_t = \frac{L}{3600V} \quad [\text{eq. 3-1}]$$

where:

T_t = travel time (hr)

L = flow length (ft)

V = average velocity (ft/s)

3600 = conversion factor from seconds to hours.

Time of concentration (T_c) is the sum of T_t values for the various consecutive flow segments:

$$T_c = T_{t_1} + T_{t_2} + \dots + T_{t_m} \quad [\text{eq. 3-2}]$$

where:

T_c = time of concentration (hr)

m = number of flow segments

Sheet flow

Sheet flow is flow over plane surfaces. It usually occurs in the headwater of streams. With sheet flow, the friction value (Manning’s n) is an effective roughness coefficient that includes the effect of raindrop impact; drag over the plane surface; obstacles such as litter, crop ridges, and rocks; and erosion and transportation of sediment. These n values are for very shallow flow depths of about 0.1 foot or so. Table 3-1 gives Manning’s n values for sheet flow for various surface conditions.

Table 3-1 Roughness coefficients (Manning’s n) for sheet flow

Surface description	n ^{1/}
Smooth surfaces (concrete, asphalt, gravel, or bare soil)	0.011
Fallow (no residue)	0.05
Cultivated soils:	
Residue cover ≤20%	0.06
Residue cover >20%	0.17
Grass:	
Short grass prairie	0.15
Dense grasses ^{2/}	0.24
Bermudagrass	0.41
Range (natural)	0.13
Woods: ^{3/}	
Light underbrush	0.40
Dense underbrush	0.80

¹ The n values are a composite of information compiled by Engman (1986).
² Includes species such as weeping lovegrass, bluegrass, buffalo grass, blue grama grass, and native grass mixtures.
³ When selecting n, consider cover to a height of about 0.1 ft. This is the only part of the plant cover that will obstruct sheet flow.

For sheet flow of less than 300 feet, use Manning’s kinematic solution (Overtop and Meadows 1976) to compute T_t:

$$T_t = \frac{0.007(nL)^{0.8}}{(P_2)^{0.5} s^{0.4}} \quad [\text{eq. 3-3}]$$

where:

- T_t = travel time (hr),
- n = Manning’s roughness coefficient (table 3-1)
- L = flow length (ft)
- P₂ = 2-year, 24-hour rainfall (in)
- s = slope of hydraulic grade line (land slope, ft/ft)

This simplified form of the Manning’s kinematic solution is based on the following: (1) shallow steady uniform flow, (2) constant intensity of rainfall excess (that part of a rain available for runoff), (3) rainfall duration of 24 hours, and (4) minor effect of infiltration on travel time. Rainfall depth can be obtained from appendix B.

Shallow concentrated flow

After a maximum of 300 feet, sheet flow usually becomes shallow concentrated flow. The average velocity for this flow can be determined from figure 3-1, in which average velocity is a function of watercourse slope and type of channel. For slopes less than 0.005 ft/ft, use equations given in appendix F for figure 3-1. Tillage can affect the direction of shallow concentrated flow. Flow may not always be directly down the watershed slope if tillage runs across the slope.

After determining average velocity in figure 3-1, use equation 3-1 to estimate travel time for the shallow concentrated flow segment.

Open channels

Open channels are assumed to begin where surveyed cross section information has been obtained, where channels are visible on aerial photographs, or where blue lines (indicating streams) appear on United States Geological Survey (USGS) quadrangle sheets. Manning’s equation or water surface profile information can be used to estimate average flow velocity. Average flow velocity is usually determined for bank-full elevation.

**POST-DEVELOPMENT HEC-HMS
ANALYSIS DRAINAGE AREAS**

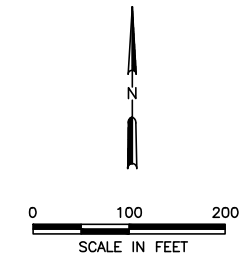
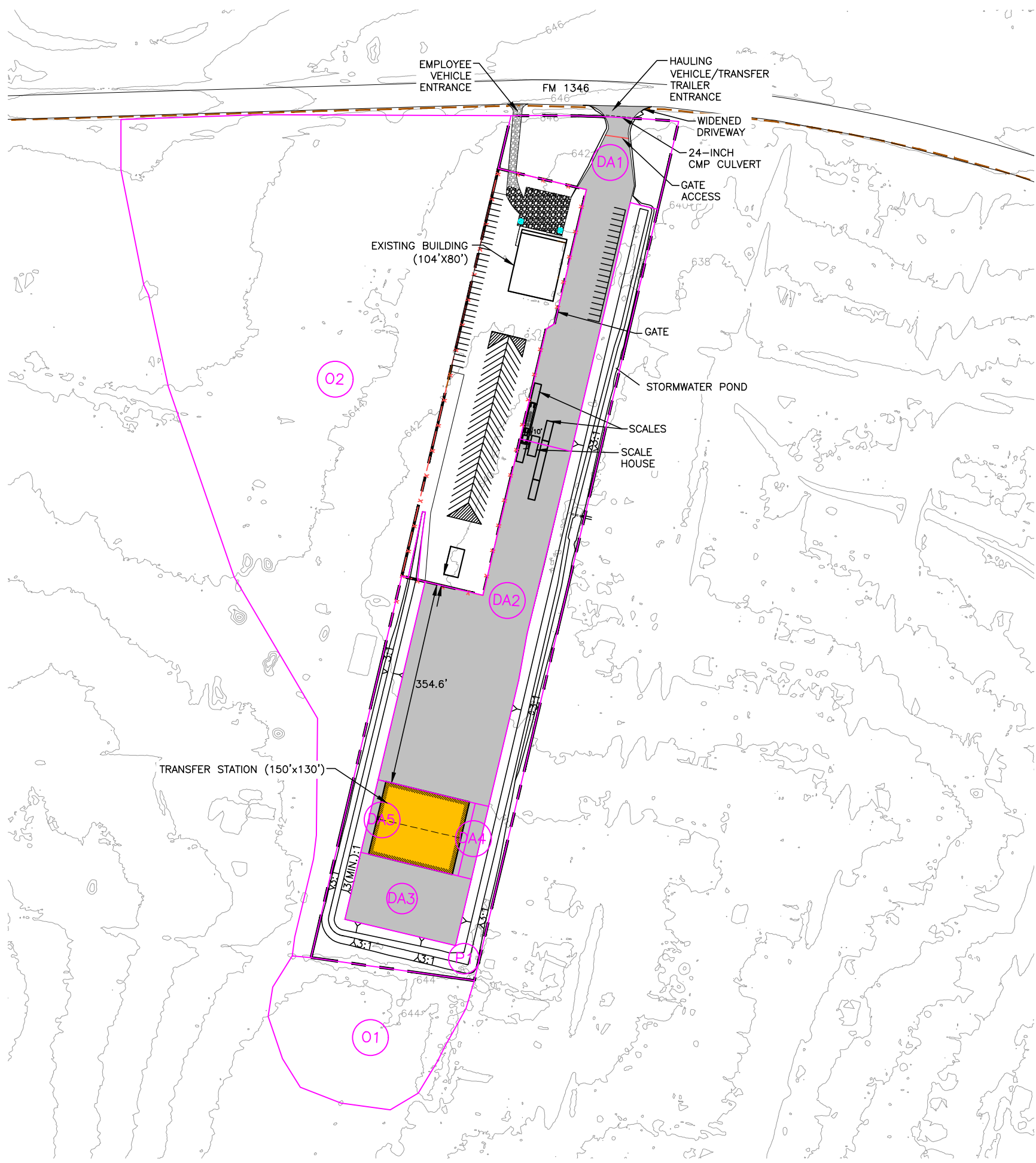

LEGEND

	430	EXISTING CONTOUR
		PROPOSED BUILDING
		EXISTING GRAVEL PAVEMENT
		PROPOSED GRAVEL PAVEMENT
		PROPOSED CONCRETE OR ASPHALT PAVEMENT OR AGGREGATE SURFACE
		ACCESS CONTROL FENCE (SEE NOTE 3)
		PROPOSED OPERATIONS AREA FENCE (SEE NOTE 2)
		DRAINAGE AREA DESIGNATION
		DRAINAGE AREA BOUNDARY

- NOTES:**
1. THE EXISTING CONTOURS PROVIDED BY TEXAS RESOURCE INFORMATION SYSTEM (TNRIS) BEXAR AND TRAVIS COUNTIES LIDAR, 2022.
 2. THE TRANSFER STATION ACCESS WILL BE CONTROLLED BY A FENCE AROUND THE PROPERTY WITH GATES ON THE FACILITY ENTRANCE ROAD. THE EXISTING 4-FOOT TALL BARBED WIRE FENCE COINCIDES WITH THE PROPERTY BOUNDARY. IN ADDITION TO THE EXISTING FENCE, AREAS WITH DENSE TREES PROVIDE A NATURAL BARRIER AROUND THE MAJORITY OF THE FACILITY BOUNDARY.
 3. PERIMETER FENCE ACCESS POINTS MAY BE INSTALLED TO FACILITATE SITE MAINTENANCE AND OPERATIONS.

HEC-HMS DRAINAGE AREAS	
DRAINAGE AREA	AREA (ACRES)
DA1	1.71
DA2	2.19
DA3	0.54
DA4	0.07
DA5	0.52
O1	1.58
O2	13.40
P1	2.5

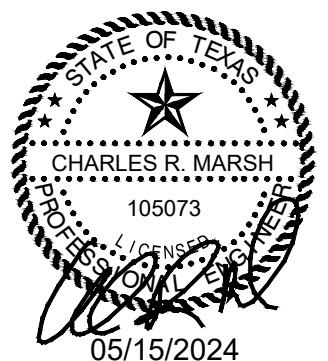

Tech. Complete App. - 353

<input type="checkbox"/> 90% REVIEW <input checked="" type="checkbox"/> FOR PERMITTING PURPOSES ONLY <input type="checkbox"/> ISSUED FOR CONSTRUCTION	PREPARED FOR WASTE CONNECTIONS LONE STAR, INC.	TYPE V PERMIT APPLICATION PROPOSED DRAINAGE PLAN SAN ANTONIO TRANSFER STATION BEXAR COUNTY, TEXAS						
	DATE: 01/2024 FILE: 0601-012-11 CAD: IIB-A-16 PROPOSED DRNG PLAN.DWG		DRAWN BY: RAA DESIGN BY: MB REVIEWED BY: CRM					
Weaver Consultants Group TBPE REGISTRATION NO. F-3727		REVISIONS <table border="1"> <thead> <tr> <th>NO.</th> <th>DATE</th> <th>DESCRIPTION</th> </tr> </thead> <tbody> <tr> <td>1</td> <td>05/2024</td> <td>PERMIT MODIFICATION</td> </tr> </tbody> </table>	NO.	DATE	DESCRIPTION	1	05/2024	PERMIT MODIFICATION
NO.	DATE	DESCRIPTION						
1	05/2024	PERMIT MODIFICATION						
WWW.WCGRP.COM		SHEET IIB-A-16						

G:\0601\12\TYPE V PERMIT APP\PART III\IIB-A-16 PROPOSED DRAINAGE PLAN.dwg, cmarsh, 1:2

**HEC-HMS OUTPUT – POST-DEVELOPMENT
25-YEAR, 24-HOUR STORM EVENT**

Project: Project_2

Simulation Run: PROPOSED-25 YEAR

Simulation Start: 1 January 2023, 01:00

Simulation End: 3 January 2023, 13:00

HMS Version: 4.11

Executed: 27 September 2023, 13:36

Global Parameter Summary - Subbasin

Area (MI²)

Element Name	Area (MI ²)
O2	0.02
P1	0
Da2	0
Da1	0
Da4	0
Da5	0
O1	0
Da3	0

Downstream

Element Name	Downstream
O2	Rp1
P1	Rp1
Da2	Rp1
Da1	Rp1
Da4	Rp1
Da5	Rp1
O1	Rp1
Da3	Rp1

Loss Rate: Scs

Element Name	Percent Impervious Area	Curve Number
O2	35	82
P1	0	99
Da2	100	98
Da1	65	90
Da4	100	98
Da5	100	98
O1	2	74
Da3	100	98

Transform: Scs

Element Name	Lag	Unitgraph Type
O2	16.2	Standard
P1	0.1	Standard
Da2	3.3	Standard
Da1	3.4	Standard
Da4	3	Standard
Da5	3	Standard
O1	12	Standard
Da3	3	Standard

Global Results Summary

Hydrologic Element	Drainage Area (MI ²)	Peak Discharge (CFS)	Time of Peak	Volume (IN)
O2	0.02	67	01Jan2023, 13:18	6.89
P1	0	27.38	01Jan2023, 13:03	8.17
Da2	0	21.31	01Jan2023, 13:04	8.29
Da1	0	16.49	01Jan2023, 13:04	7.87
Da4	0	0.64	01Jan2023, 13:04	8.29
Da5	0	5.12	01Jan2023, 13:04	8.29
O1	0	7.55	01Jan2023, 13:14	5.25
Da3	0	5.12	01Jan2023, 13:04	8.29
Rp1	0.04	91.68	01Jan2023, 13:18	7.19

Subbasin: O2

Area (MI²) : 0.02

Downstream : RPI

Loss Rate: SCS

Percent Impervious Area	35
Curve Number	82

Transform: SCS

Lag	16.2
Unitgraph Type	Standard

Results: O2

Peak Discharge (CFS)	67
Time of Peak Discharge	01Jan2023, 13:18
Volume (IN)	6.89
Precipitation Volume (AC - FT)	9.24
Loss Volume (AC - FT)	1.56
Excess Volume (AC - FT)	7.68
Direct Runoff Volume (AC - FT)	7.68
Baseflow Volume (AC - FT)	0

Precipitation and Outflow

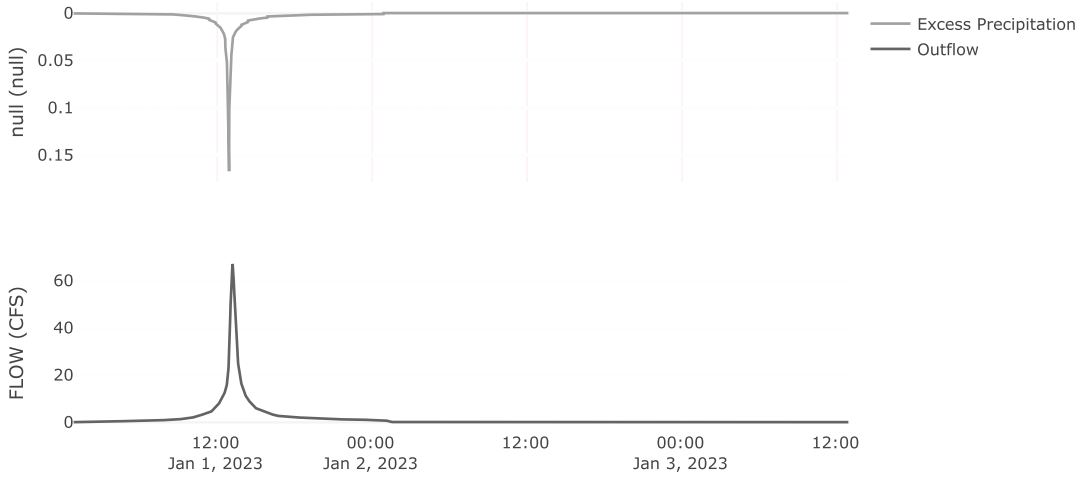

Cumulative Outflow

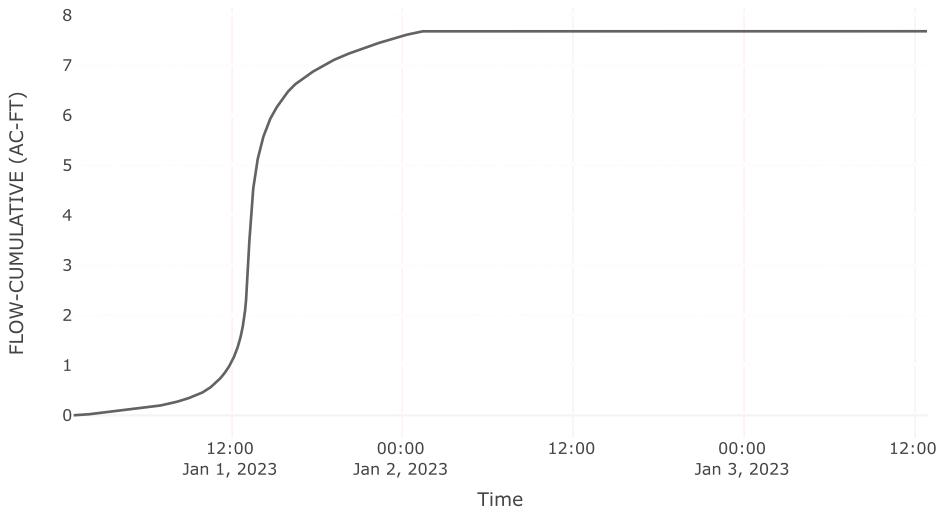

Subbasin: P1

Area (MI²) : 0

Downstream : RPI

Loss Rate: SCS

Percent Impervious Area	0
Curve Number	99

Transform: SCS

Lag	0.1
Unitgraph Type	Standard

Results: P1

Peak Discharge (CFS)	27.38
Time of Peak Discharge	01Jan2023, 13:03
Volume (IN)	8.17
Precipitation Volume (AC - FT)	1.72
Loss Volume (AC - FT)	0.02
Excess Volume (AC - FT)	1.7
Direct Runoff Volume (AC - FT)	1.7
Baseflow Volume (AC - FT)	0

Precipitation and Outflow

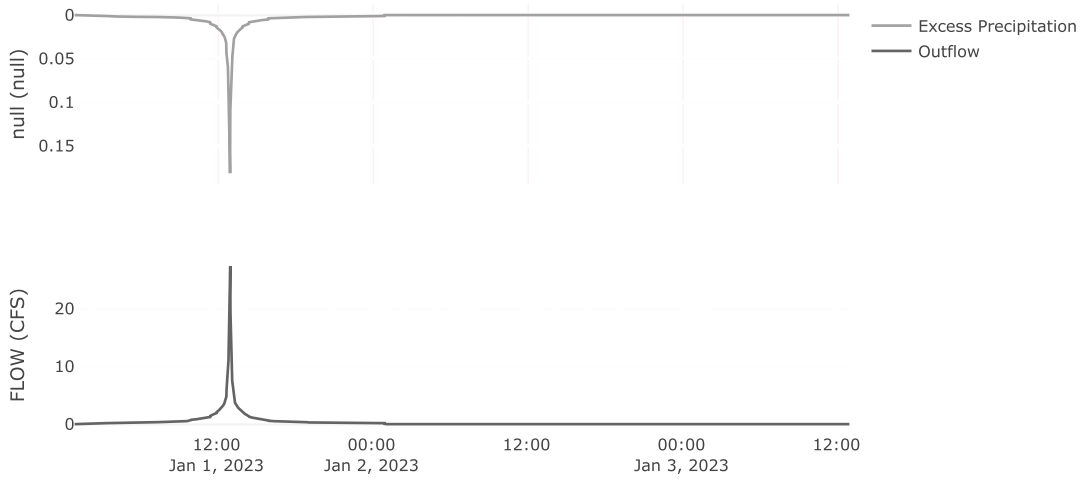

Cumulative Outflow

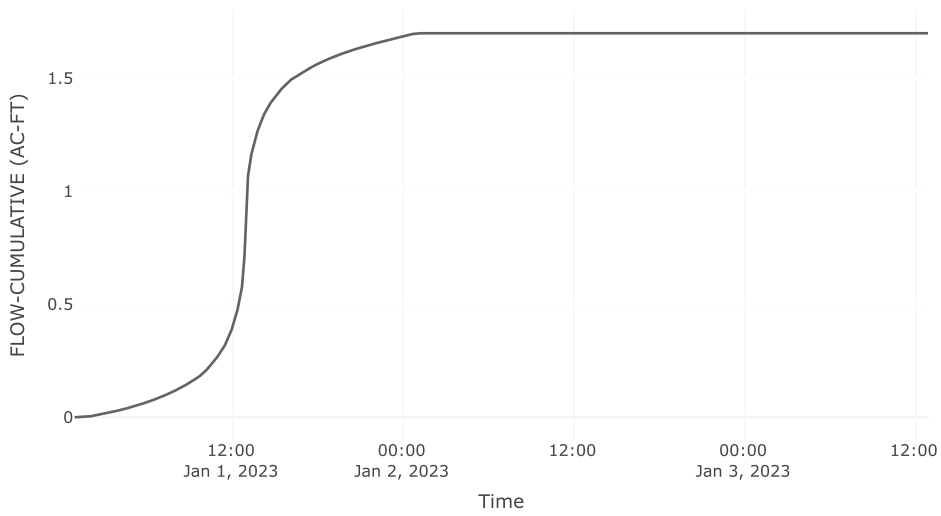

Subbasin: DA2

Area (MI²) : 0

Downstream : RPI

Loss Rate: SCS

Percent Impervious Area	100
Curve Number	98

Transform: SCS

Lag	3.3
Unitgraph Type	Standard

Results: DA2

Peak Discharge (CFS)	21.31
Time of Peak Discharge	01Jan2023, 13:04
Volume (IN)	8.29
Precipitation Volume (AC - FT)	1.5
Loss Volume (AC - FT)	0
Excess Volume (AC - FT)	1.5
Direct Runoff Volume (AC - FT)	1.5
Baseflow Volume (AC - FT)	0

Precipitation and Outflow

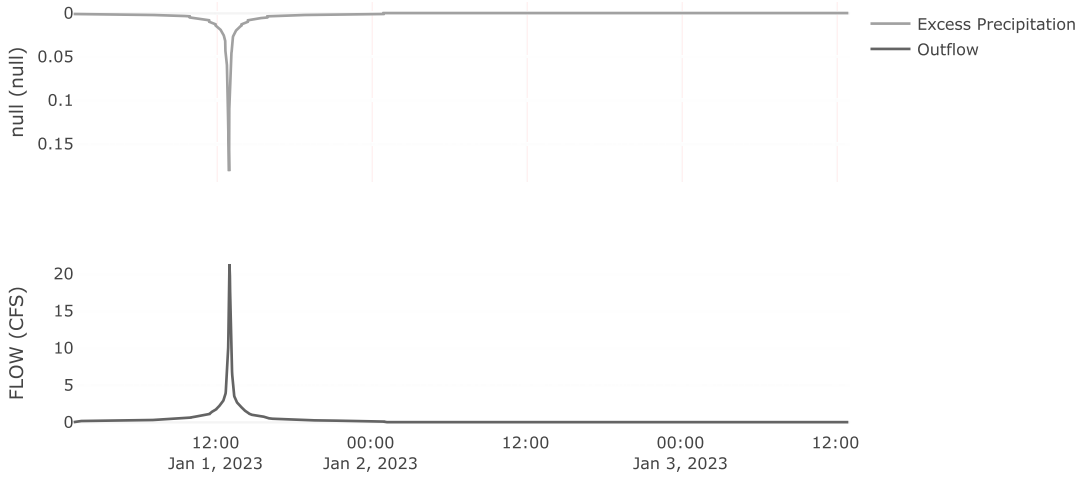

Cumulative Outflow

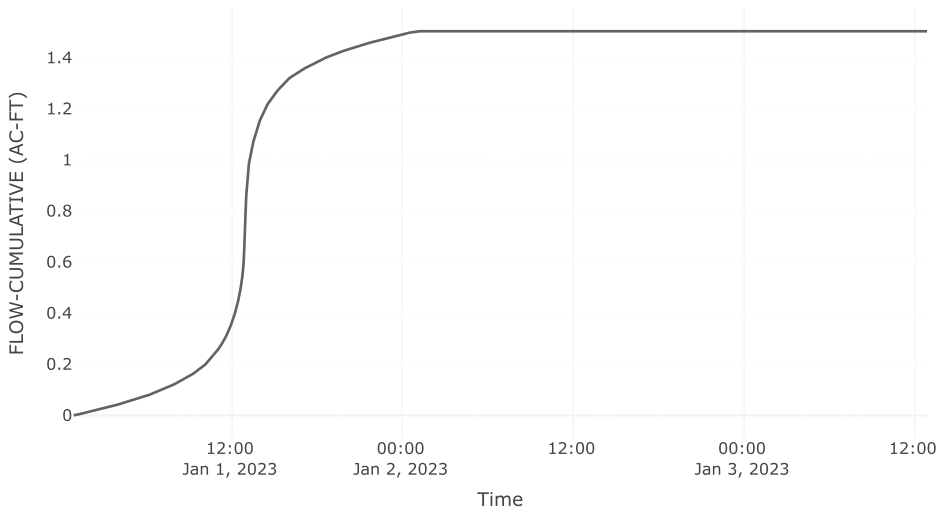

Subbasin: DA1

Area (MI²) : 0

Downstream : RPI

Loss Rate: SCS

Percent Impervious Area	65
Curve Number	90

Transform: SCS

Lag	3.4
Unitgraph Type	Standard

Results: DA1

Peak Discharge (CFS)	16.49
Time of Peak Discharge	01Jan2023, 13:04
Volume (IN)	7.87
Precipitation Volume (AC - FT)	1.19
Loss Volume (AC - FT)	0.06
Excess Volume (AC - FT)	1.13
Direct Runoff Volume (AC - FT)	1.13
Baseflow Volume (AC - FT)	0

Precipitation and Outflow

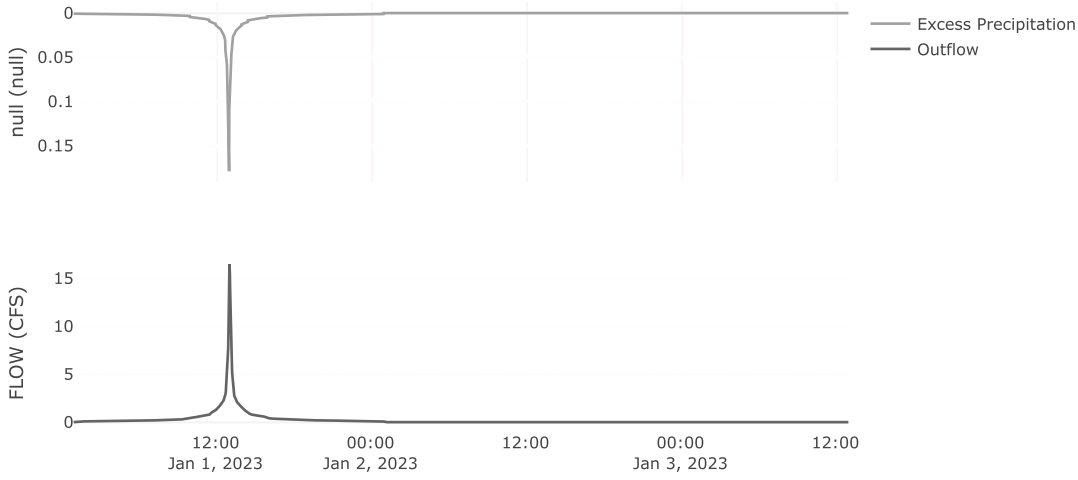

Cumulative Outflow

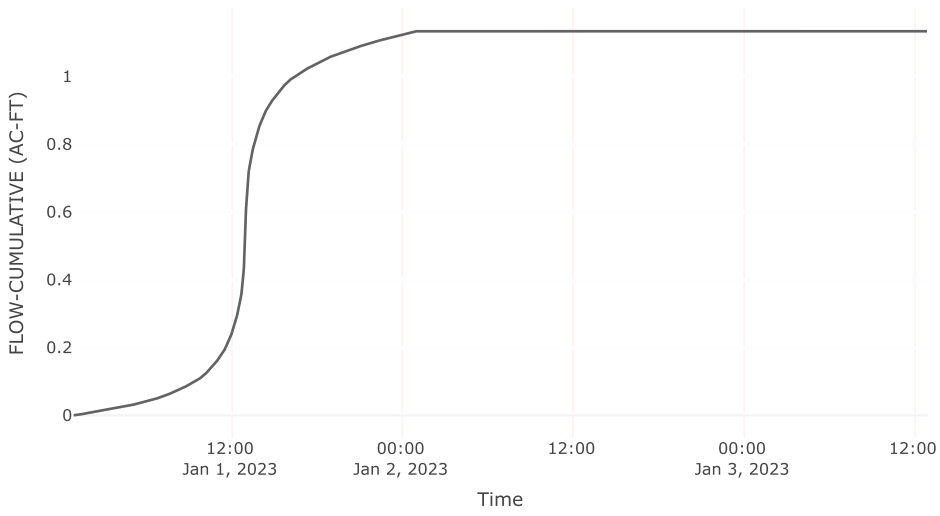

Subbasin: DA4

Area (MI²) : 0

Downstream : RPI

Loss Rate: Scs

Percent Impervious Area	100
Curve Number	98

Transform: Scs

Lag	3
Unitgraph Type	Standard

Results: DA4

Peak Discharge (CFS)	0.64
Time of Peak Discharge	01Jan2023, 13:04
Volume (IN)	8.29
Precipitation Volume (AC - FT)	0.04
Loss Volume (AC - FT)	0
Excess Volume (AC - FT)	0.04
Direct Runoff Volume (AC - FT)	0.04
Baseflow Volume (AC - FT)	0

Precipitation and Outflow

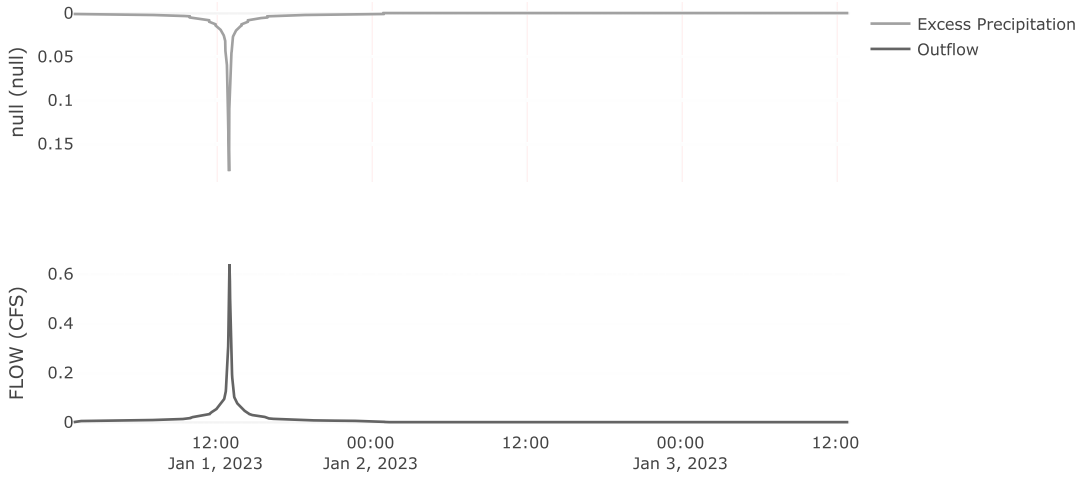

Cumulative Outflow

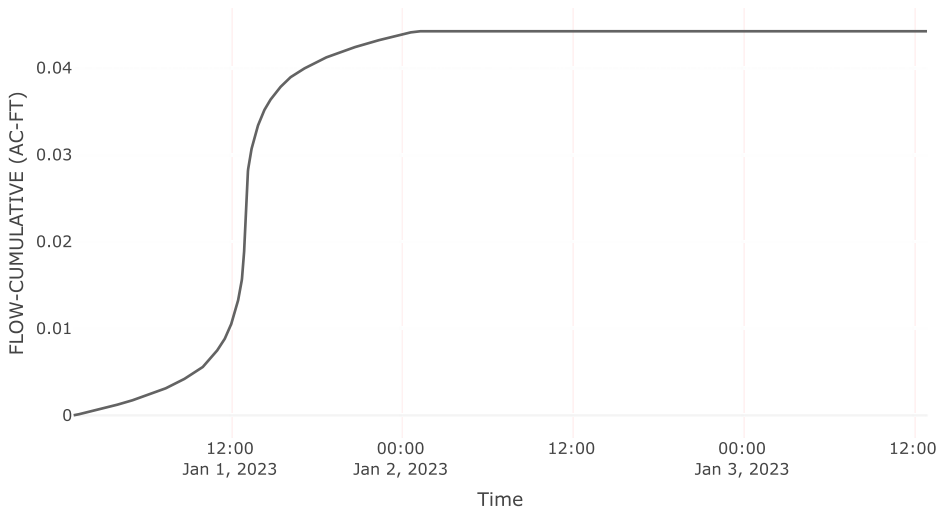

Subbasin: DA5

Area (MI²) : 0

Downstream : RPI

Loss Rate: Scs

Percent Impervious Area	100
Curve Number	98

Transform: Scs

Lag	3
Unitgraph Type	Standard

Results: DA5

Peak Discharge (CFS)	5.12
Time of Peak Discharge	01Jan2023, 13:04
Volume (IN)	8.29
Precipitation Volume (AC - FT)	0.35
Loss Volume (AC - FT)	0
Excess Volume (AC - FT)	0.35
Direct Runoff Volume (AC - FT)	0.35
Baseflow Volume (AC - FT)	0

Precipitation and Outflow

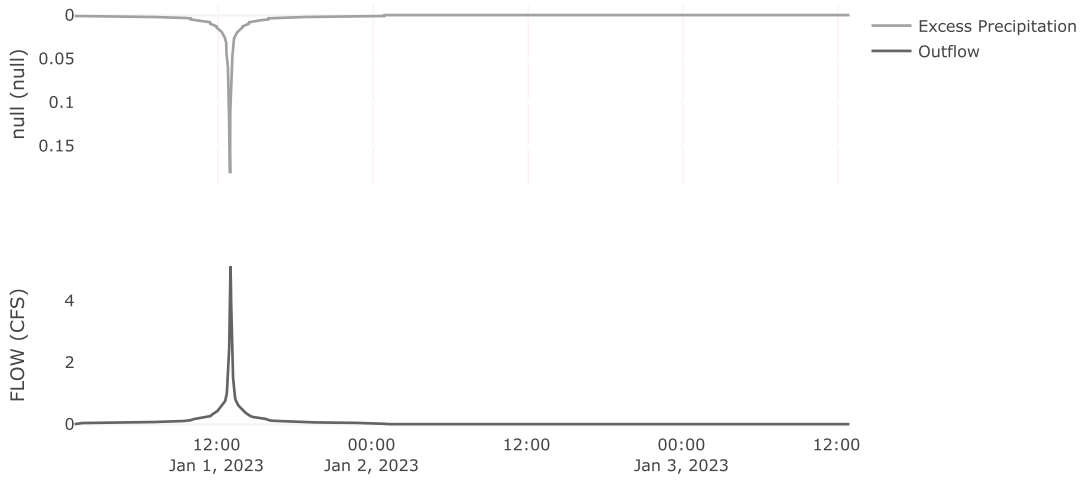

Cumulative Outflow

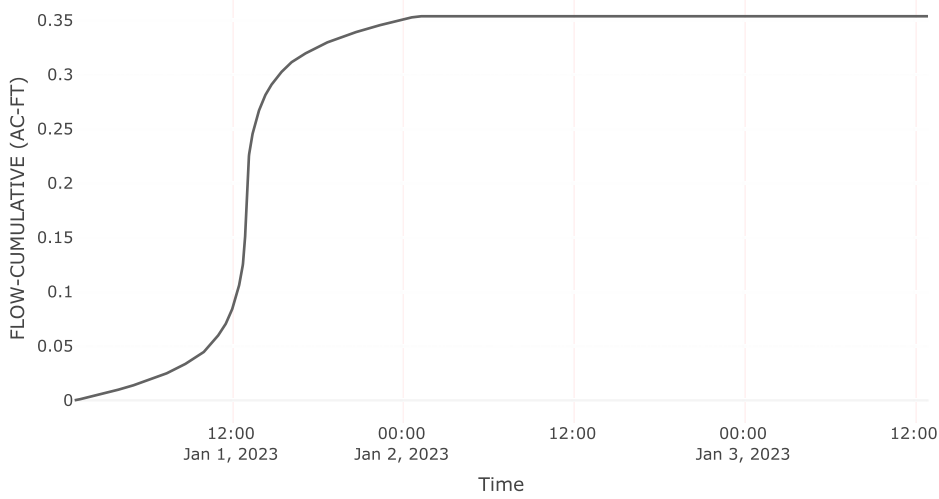

Subbasin: OI

Area (MI²) : 0

Downstream : RPI

Loss Rate: SCS

Percent Impervious Area	2
Curve Number	74

Transform: SCS

Lag	12
Unitgraph Type	Standard

Results: OI

Peak Discharge (CFS)	7.55
Time of Peak Discharge	01Jan2023, 13:14
Volume (IN)	5.25
Precipitation Volume (AC - FT)	1.11
Loss Volume (AC - FT)	0.41
Excess Volume (AC - FT)	0.7
Direct Runoff Volume (AC - FT)	0.7
Baseflow Volume (AC - FT)	0

Precipitation and Outflow

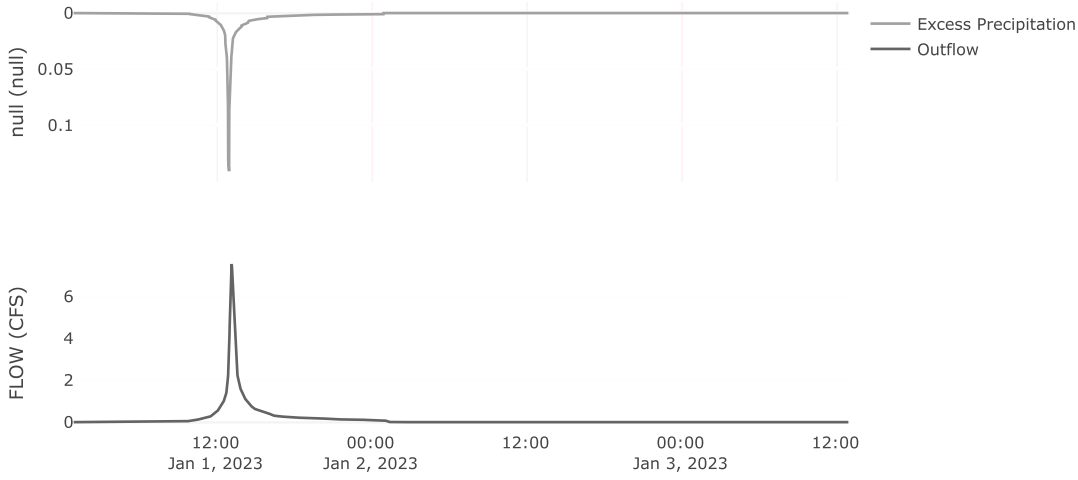

Cumulative Outflow

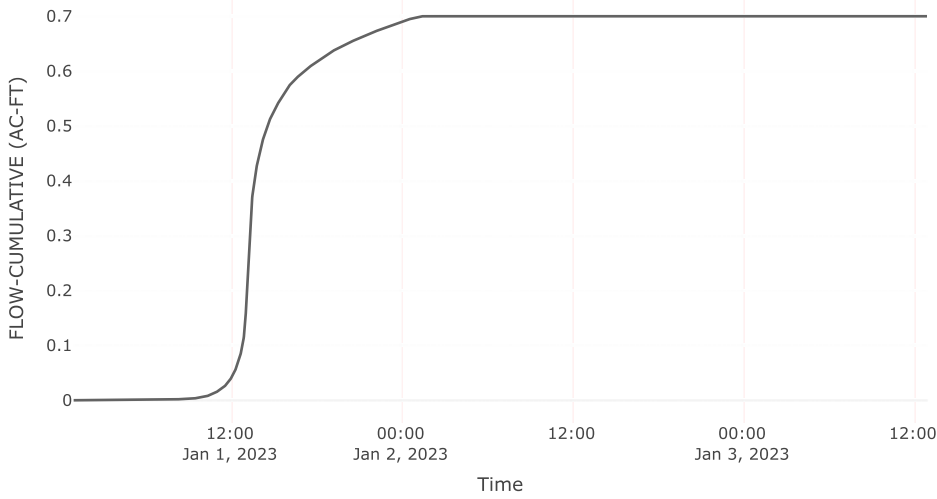

Subbasin: DA3

Area (MI²) : 0

Downstream : RPI

Loss Rate: Scs

Percent Impervious Area	100
Curve Number	98

Transform: Scs

Lag	3
Unitgraph Type	Standard

Results: DA3

Peak Discharge (CFS)	5.12
Time of Peak Discharge	01Jan2023, 13:04
Volume (IN)	8.29
Precipitation Volume (AC - FT)	0.35
Loss Volume (AC - FT)	0
Excess Volume (AC - FT)	0.35
Direct Runoff Volume (AC - FT)	0.35
Baseflow Volume (AC - FT)	0

Precipitation and Outflow

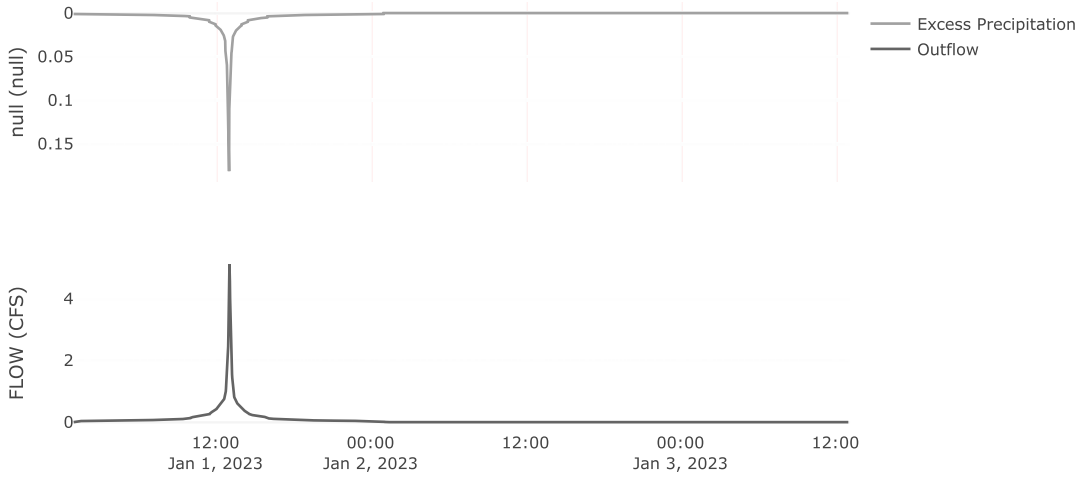

Cumulative Outflow

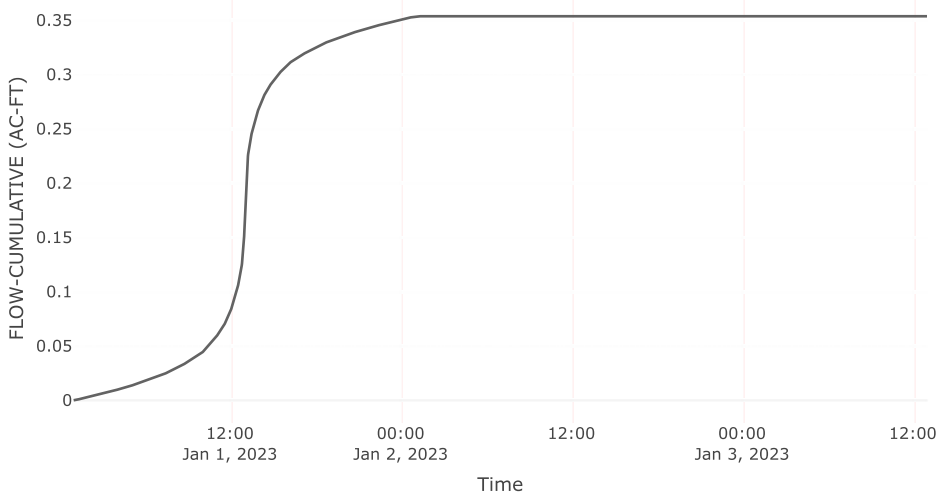

Reservoir: RPI

Results: RPI

Peak Discharge (CFS)	91.68
Time of Peak Discharge	01 Jan 2023, 13:18
Volume (IN)	7.19
Peak Inflow (CFS)	107.52
Time of Peak Inflow	01 Jan 2023, 13:03
Inflow Volume (AC - FT)	13.47
Maximum Storage (AC - FT)	1.81
Peak Elevation (FT)	640.4
Discharge Volume (AC - FT)	13.46

Reservoir Area

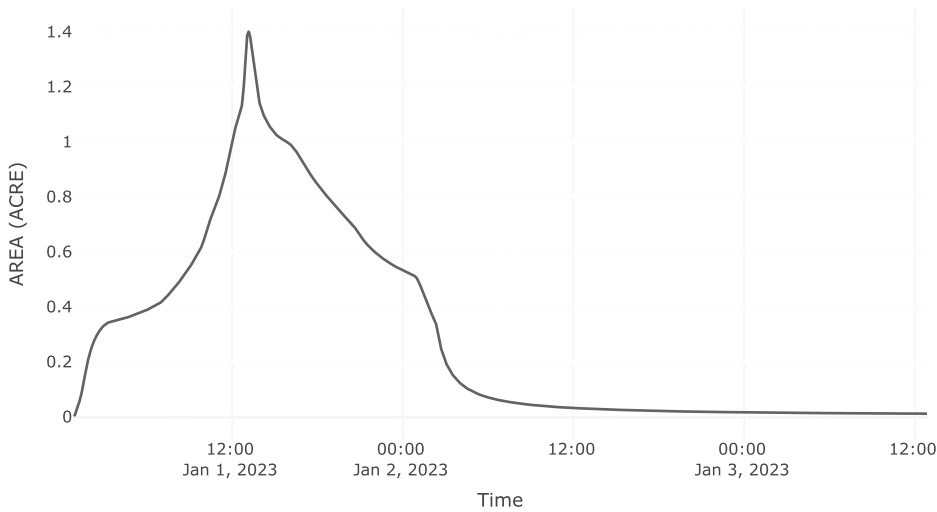

Storage

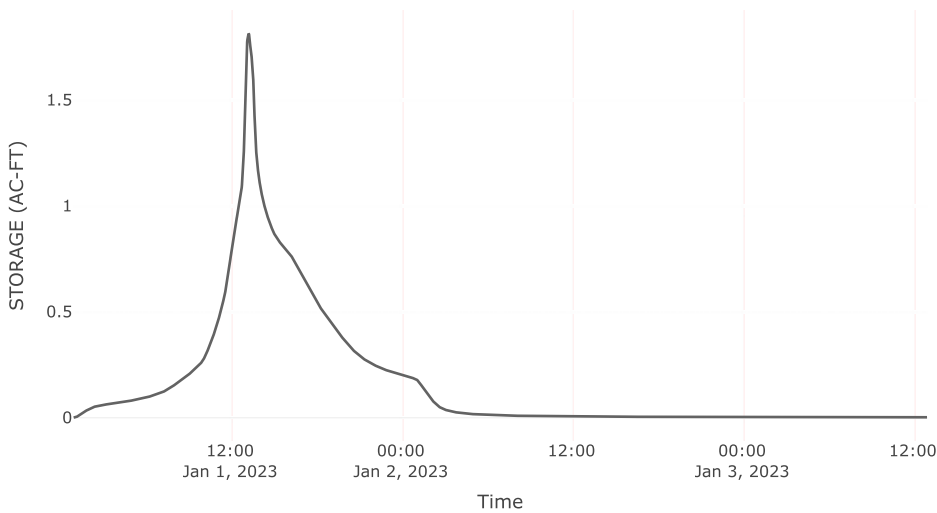

Combined Inflow

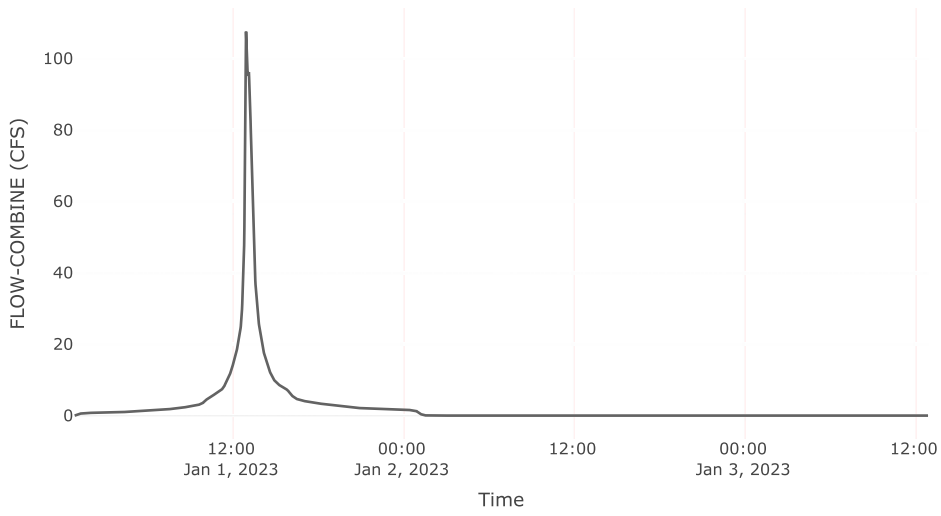

Cumulative Outflow

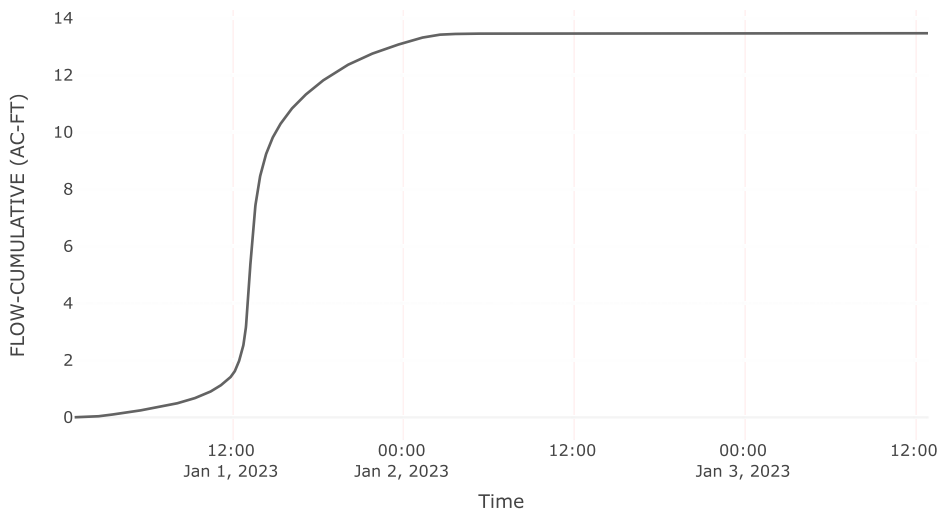

Spillway 1

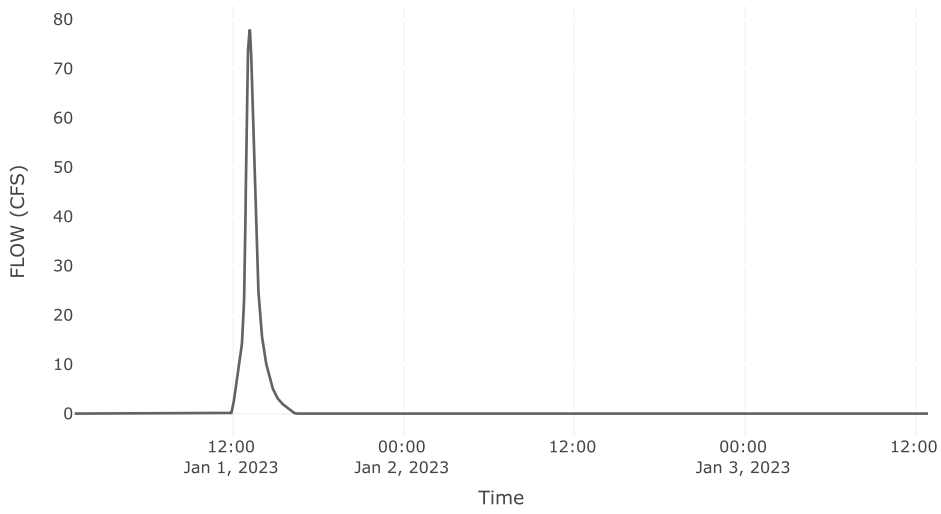

Outlet 1

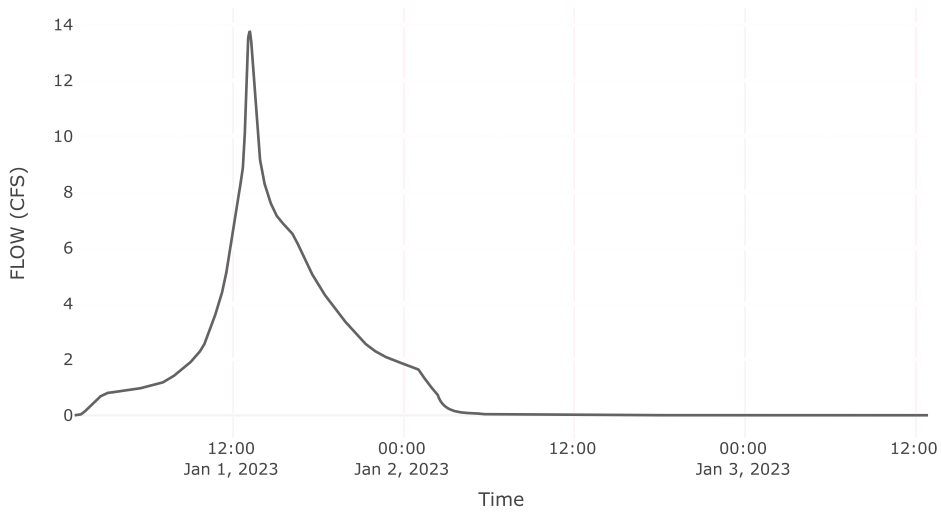

Pool Elevation

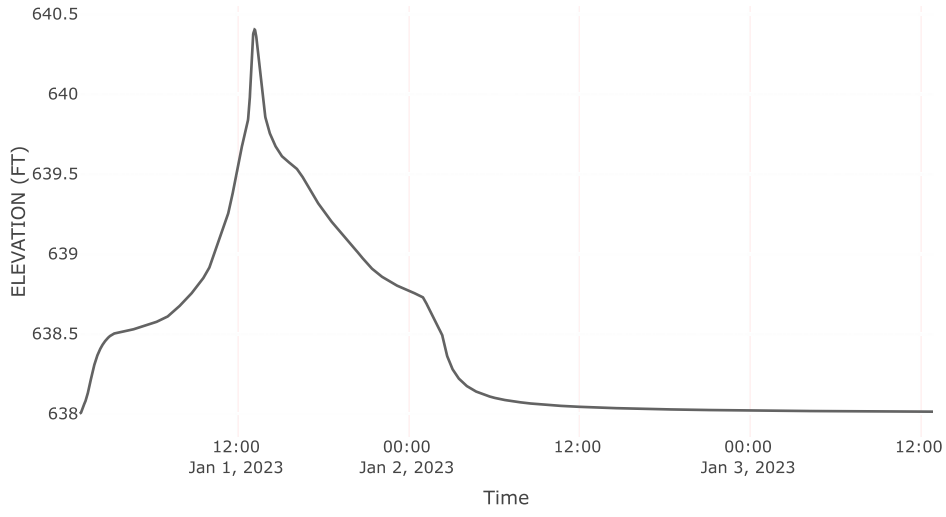

Outflow

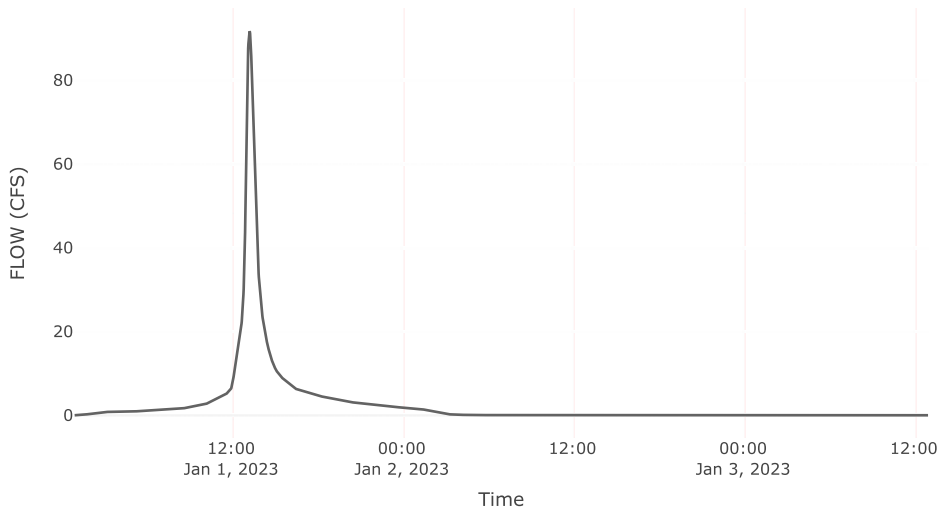

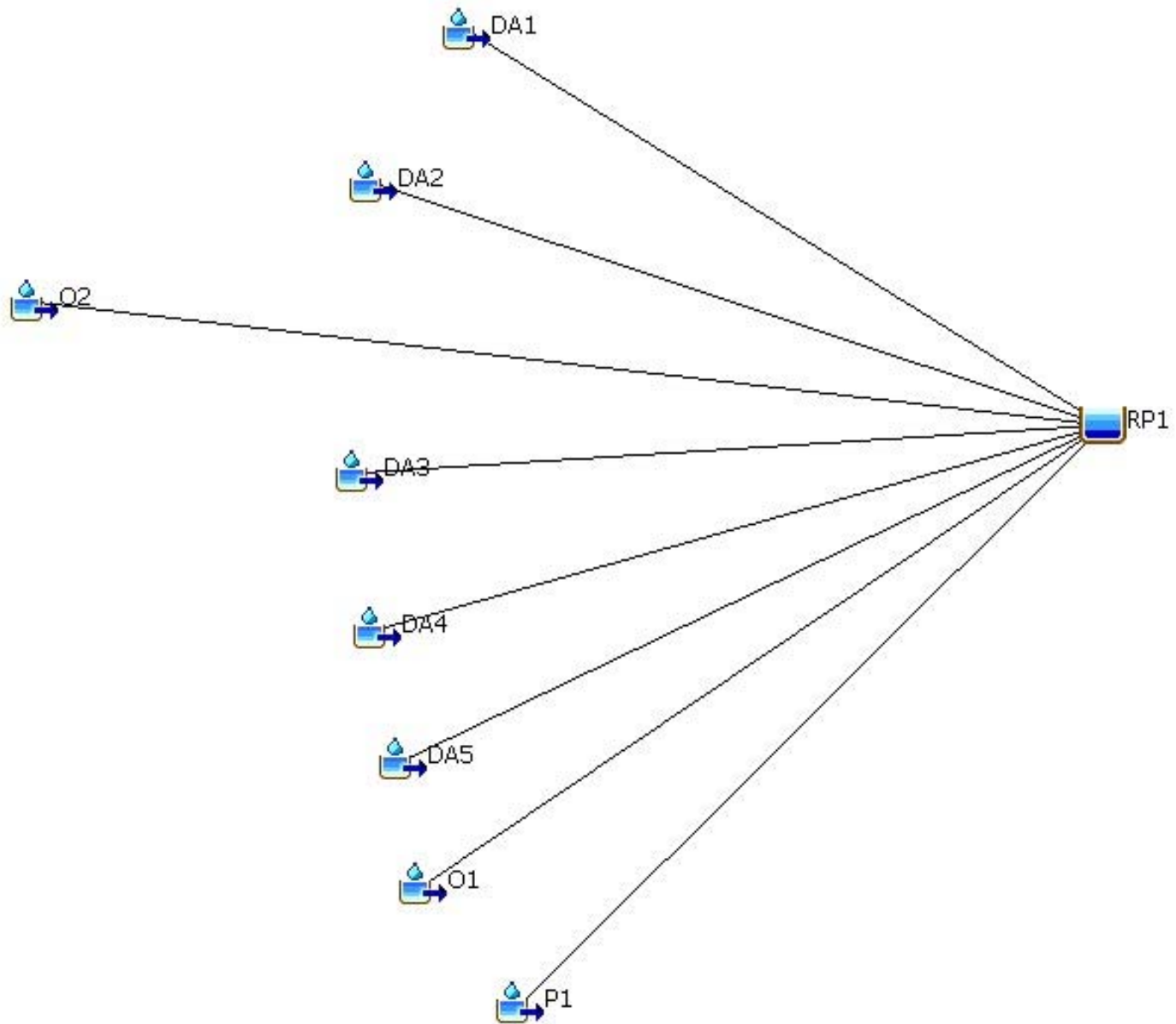

VOLUME CALCULATIONS

EXCESS RAINFALL VOLUME CALCULATION

The volume generated by the site and the surrounding properties is calculated for the 25-year, 24-hour storm event. A summary of the design information that is included in this Appendix and related appendices are listed below.

- Volume calculations were taken from the HEC-HMS Global Summary Table located on Page IIIB-A-19 in Appendix IIIB-A (post-development).
- Post-development condition volume information is summarized on page IIIB-A-43.

Required: Determine the 25-year 24-hour storm volume generated by the site and offsite areas using the excess rainfall calculated in the HEC-HMS analysis of the post-development expansion site conditions.

Method: Use the excess rainfall data generated by the HEC-HMS analysis (pages IIIB-A-18 through IIIB-A-40) to determine the volume produced by the site for the post-development expansion conditions.

Post-Development Expansion Conditions

1. Total Volume at DPO1

Area No.	Area (ac)	Volume (in)	Volume (ac-ft)
O1	1.58	5.25	0.69
Total Volume Discharging At DPO1			0.69

2. Total Volume at DPO2

Area No.	Area (ac)	Volume (in)	Volume (ac-ft)
O2	13.40	6.89	7.69
Total Volume Discharging At DPO2			7.69

3. Total Volume at DP1

Area No.	Area (ac)	Volume (in)	Volume (ac-ft)
DA1	1.71	7.87	1.12
DA2	2.19	8.29	1.51
DA3	0.54	8.29	0.37
DA4	0.07	8.29	0.05
DA5	0.52	8.29	0.36
O1	1.58	5.25	0.69
O2	13.40	6.89	7.69
P1	2.50	8.17	1.70
Total Volume Discharging At DP1			13.50

VELOCITY CALCULATIONS

Required: Determine the flow velocities entering and exiting the permit boundary using HYDROCALC HYDRAULICS (Version 2.0.1 1996-2010) for the flows calculated for the 25-year 24-hour storm event in the HEC-1 analysis.

Method:
1. Use the flow data generated by the HEC-HMS analysis to determine velocity of runoff entering and exiting the Transfer Station permit boundary.

1. Flow Velocity entering the Transfer Station permit boundary
Flow for the 25-year 24-hour storm event was obtained from the HEC-HMS file included in this Appendix.

DPO 1

$$Q_{25} = 7.55 \text{ cfs}$$

Storm Year	Flow Rate (cfs)	Bottom Slope (ft/ft)	n-value	Side Slope (left)	Side Slope (right)	Bottom Width (ft)	Normal Depth (ft)	Flow Vel. (fps)
25	7.55	0.004	0.04	100	100	287	0.07	0.39

Note: Calculations were performed using the HYDROCALC HYDRAULICS for Windows program developed by Dodson and Associates (Version 2.01, 1996-2010).

2. Flow Velocity entering the Transfer Station permit boundary
Flow for the 25-year 24-hour storm event was obtained from the HEC-HMS file included in this Appendix.

DPO2

$$Q_{25} = 67.00 \text{ cfs}$$

Storm Year	Flow Rate (cfs)	Bottom Slope (ft/ft)	n-value	Side Slope (left)	Side Slope (right)	Bottom Width (ft)	Normal Depth (ft)	Flow Vel. (fps)
25	67	0.008	0.04	100	100	729	0.12	0.79

Note: Calculations were performed using the HYDROCALC HYDRAULICS for Windows program developed by Dodson and Associates (Version 2.01, 1996-2010).

3. Flow Velocity exiting the Transfer Station permit boundary
Flow for the 25-year 24-hour storm event was obtained from the HEC-HMS file included in this Appendix.

DP1

$$Q_{25} = 91.69 \text{ cfs}$$

Storm Year	Flow Rate (cfs)	Bottom Slope (ft/ft)	n-value	Side Slope (left)	Side Slope (right)	Bottom Width (ft)	Normal Depth (ft)	Flow Vel. (fps)
25	91.69	0.005	0.04	100	100	100	0.47	1.32

Note: Calculations were performed using the HYDROCALC HYDRAULICS for Windows program developed by Dodson and Associates (Version 2.01, 1996-2010).

APPENDIX IIIB-B

CULVERT CALCULATIONS

Includes pages IIIB-B-1 through IIIB-B-5

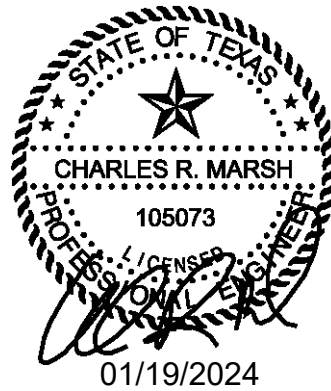

CONTENTS

Culvert Calculation

IIIB-B-1

Erosion Protection Calculation

IIIB-B-4



CULVERT CALCULATION

Required: Design culverts to convey the flow.

Method: Use HYDROCALC Hydraulics for Windows computer program to determine number and size of the culverts.
Use total 25-year frequency storm event flow estimated by HEC-HMS included in Appendix

Total Flow= 12.8 cfs
No. of Culverts= 1
Culvert Span= -- inches
Culvert Rise= -- inches
Culvert Diameter= 24 inches

Culvert ID	Culvert Span	Culvert Span	FHWA Chart Number	FHWA Scale Number	Culvert Diameter	Manning's Coefficient	Entrance Loss Coefficient	Culvert Length	Downstream Invert Elevation	Upstream Invert Elevation	Flow Rate	Tailwater Depth ²	Headwater Inlet Control	Headwater Outlet Control	Normal Depth	Critical Depth	Depth at Outlet	Outlet Velocity
	(ft)	(ft)			(ft)			(ft)	(ft msl)	(ft msl)	(cfs)	(ft)	(ft)	(ft)	(ft)	(ft)	(ft)	(fps)
1	--	--	2	2	2	0.024	0.8	20.00	637.50	638.00	12.80	0.47	1.95	0.00	1.19	1.29	1.19	6.59

- Calculations were performed using the HYDROCALC Hydraulics for Windows program developed by Dodson and Associates (Version 2.0, 1996-2010).
- Tailwater depth is assumed to be the 25-year, 24-hour normal depth in the channel right after the culvert.

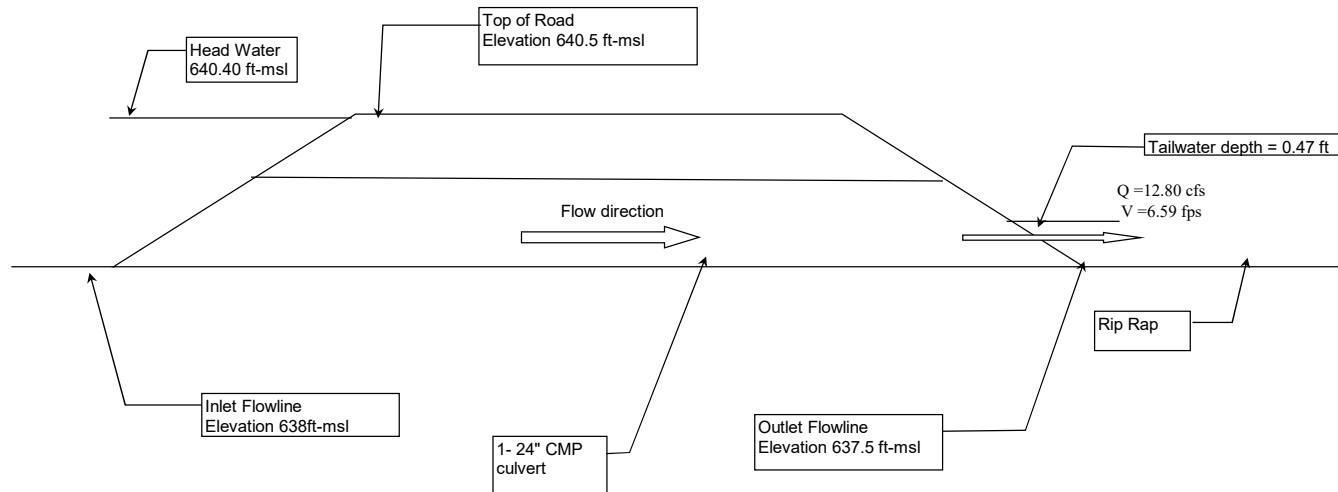

Purpose: Demonstrate that the detention pond outlet structure designs are adequate to convey runoff from the various subbasins to their discharge points.

Method:

1. Use the 25-year, 24-hour flow rates and water surface elevations for the drainage areas that will discharge to each detention pond from the HEC-HMS analysis (see Appendix IIIB-A).
2. Use the Weir Equation to calculate the flow rate over the spillways as appropriate.

Solution:

25-Year 24-Hour Storm	Pond 1
Bottom ELEV, ft	638.00
Spillway ELEV, ft	639.50
Spillway Length, ft	35
Top of TS Pavement, ft	640.50
Discharge Pipe Downstream Invert ELEV, ft	637.50
Peak Inflow Q ₂₅ , cfs	107.52
Peak Outflow Q ₂₅ , cfs	91.69
Peak Stage in Pond, ft	640.40
Est. Flow (Q ₂₅) over Spillway, cfs	78.89
Velocity (V ₂₅) over Spillway, fps	1.39

Note:

- (1) The flow over the spillway is estimated using the formula $Q = CLH^{3/2}$ where $C = 2.64$, L is the length of the spillway in feet, and H is the head on the spillway in feet. The flow over the spillway conservatively assumes no flow through the low water outlet.
- (2) Calculations for velocity over the spillway were performed using the HYDROCALC HYDRAULICS FOR WINDOWS Computer Program developed by Dodson and Associates (Version 1.2a, 1996).

Required: Determine the minimum length and median diameter of riprap required at the detention pond and channel outlet structures to control erosion.

- Reference:**
1. Haan, Barfield, and Hayes, *Design Hydrology and Sedimentology for Small Catchments*, 1994.
 2. HEC-HMS, U.S. Army Corps of Engineers, Institute For Water Resources, Hydrologic Engineering Center.

Solution: The riprap will be designed for the 25-year flow rates at the detention pond and channel outlet structures. The flow at the outlet structure can be divided into two categories:

1. Flow over the Spillway

As shown on page IIIB-B-3, erosive velocities over the spillway (pond 1) is not anticipated.

2. Flow through the Low Water Outlet

The flow rate through the low water outlet (LWO) is summarized below.

Flow Structure	Pond Bottom Elev (ft-msl)	LWO Invert Elev.		LWO Diameter (in)	25-Year Flow Rate ² (cfs)	25-Year Outlet Velocity ¹ (ft/s)
		Upstream (ft-msl)	Downstream (ft-msl)			
P1	638.0	638.0	637.5	24	12.8	6.59

Velocities through the low water outlet were calculated using the HYDROCALC

¹ HYDRAULICS FOR WINDOWS program developed by Dodson and Associates (Version 1.2a, 1996).

The flow rates were obtained from the HEC-HMS analysis output.

² The flow rate used for riprap design will be the flow passing through the LWO.

The nomograph used for design of the length of the riprap and the median diameter is shown on pages IIIB-B-5 (Figures 5.24 and 5.25).

The minimum riprap length and median rock diameter for each outlet is summarized below. The length of the riprap is increased by 20 percent to provide for a conservative design.

Pond	Flow in LWO (cfs)	Riprap Length (ft)	Adjusted Length L x 1.2 (ft)	Median Rock Diameter (ft)
P1	12.8	3	3.6	0.30

Apron width (W) for ponds LWO:

$$W = \text{LWO diameter} + 0.4 * (\text{Adjusted RipRap Length})$$

Pond	W (ft)
P1	3.9

The median diameter of riprap is intended to determine the minimum diameter of the riprap that will be used. As an alternative, 18-inch thick gabions can be used.

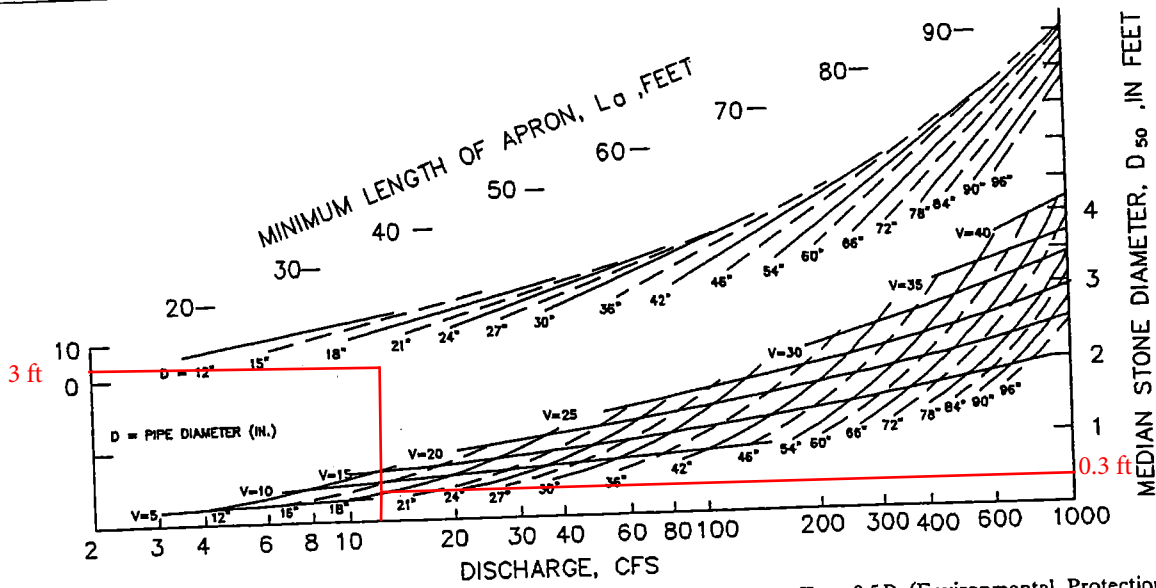

Figure 5.24 Design of outlet protection—minimum tailwater condition, $T_w < 0.5D$ (Environmental Protection Agency, 1976).

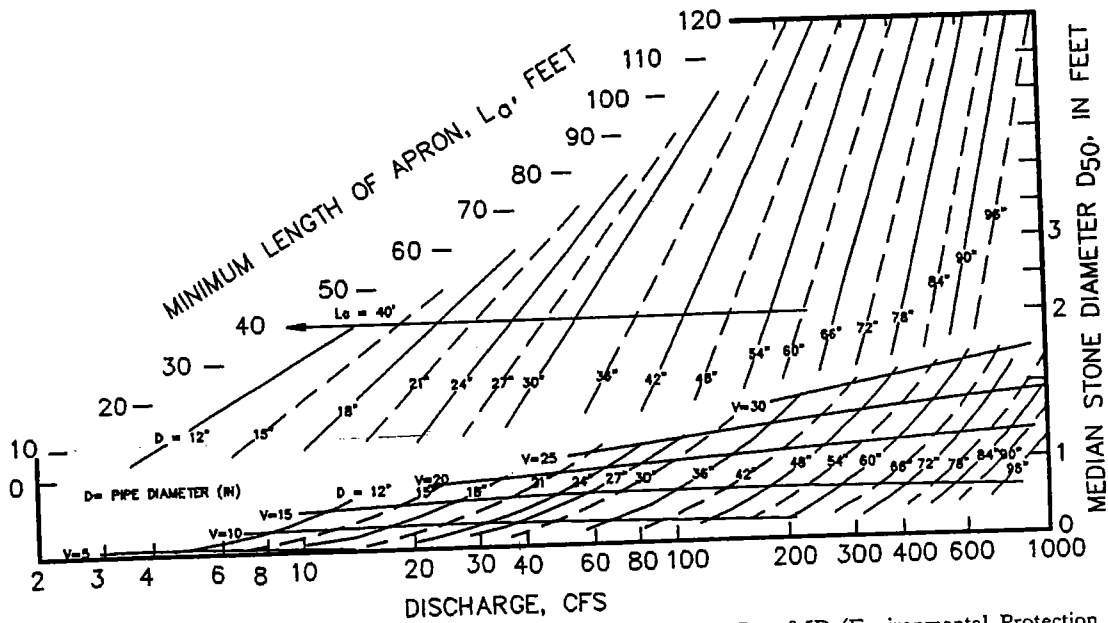

Figure 5.25 Design of outlet protection—maximum tailwater condition, $T_w \geq 0.5D$ (Environmental Protection Agency, 1976).

into the riser 3 ft below its top, what discharge will pass through the four holes with the water level at 1, 2, 4, and 8 ft above the riser? (c) What is the total discharge through the pipe? (d) How might the orifices be sized to provide better stormwater control? (e) Explain whether you would expect two rows (each consisting of four holes) of 8-in.-diameter holes to provide better results? Assume that one row is 2 ft below the riser invert and the other row is 4 ft below the riser invert.

(5.6) A gravel roadway is constructed in a low-lying area such that the roadway is frequently overtopped as a result of severe storms. The roadway is 40 ft wide, and its elevation is 36 ft. (a) If the water level upstream of the roadway is 2 ft above the crest of the roadway, what is the discharge across the roadway? (b) If the roadway is paved, what upstream depth would be required to carry the same flow? (c) Would paving reduce flooding problems?

APPENDIX IIIB-C

**EXISTING CONDITION
DRAINAGE ANALYSIS**

Includes pages IIIB-C-1 through IIIB-C-34

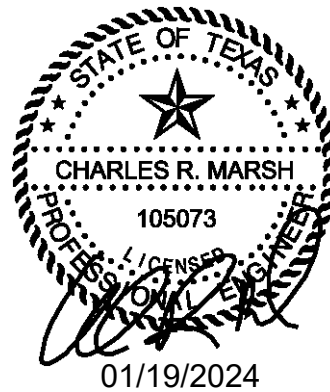

CONTENTS

Hypothetical Storm Data	IIIB-C-1
Precipitation Loss Data	IIIB-C-3
Hydrograph Development Information	IIIB-C-8
Existing Condition HEC-HMS Analysis Drainage Areas	IIIB-C-11
HEC-HMS Output – Existing Condition 25-Year, 24-Hour Storm Event	IIIB-C-13
Volume Calculations	IIIB-C-30
Velocity Calculations	IIIB-C-33



HYPOTHETICAL STORM DATA

Hypothetical Storm Data

Precipitation data taken from NOAA Atlas 14, Volume 11, Version 2.

Time	5 min	15 min	60 min	2 hr	3 hr	6 hr	12 hr	24 hr
25 Year Event	0.907	1.8	3.34	4.39	5.07	6.22	7.24	8.29

PRECIPITATION LOSS DATA

Required: Determine the SCS curve numbers for the on-site drainage areas and pond for use in the HEC-HMS analysis.

References:

1. HEC-HMS, U.S. Army Corps of Engineers, Institute For Water Resources, Hydrologic Engineering Center.
2. United States Department of Agriculture, National Resource Conservation Service, Web Soil Survey for Collin County, Texas (<http://websoilsurvey.nrcs.usda.gov>).

Solution: Based on the soil survey information found in Ref. 2, hydrologic group C soils predominate the soils within the permit boundary drainage area (see pages IIIB-A-5 through IIIB-A-7).

The non-impervious portions of subbasins (e.g., non-paved areas) were considered to be open space, contoured and in good condition. A curve number was selected using the provided drainage manual and the Web Soil Survey.

Use: CN = 74

The curve number for the proposed impervious, concrete-paved areas was selected using the provided drainage manual and the Web Soil Survey.

Use: CN = 98

The pond area is assumed to consist of areas that have zero precipitation losses (water surfaces) with vegetated sideslopes and gravel-surfaced top of embankment areas

Use: CN = 99







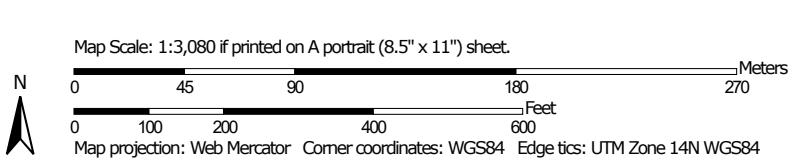

























Hydrologic Soil Group—Bexar County, Texas



Soil Map may not be valid at this scale.



MAP LEGEND

- Area of Interest (AOI)**
 -  Area of Interest (AOI)
- Soils**
 - Soil Rating Polygons**
 -  A
 -  A/D
 -  B
 -  B/D
 -  C
 -  C/D
 -  D
 -  Not rated or not available
 - Soil Rating Lines**
 -  A
 -  A/D
 -  B
 -  B/D
 -  C
 -  C/D
 -  D
 -  Not rated or not available
 - Soil Rating Points**
 -  A
 -  A/D
 -  B
 -  B/D
- Water Features**
 -  Streams and Canals
- Transportation**
 -  Rails
 -  Interstate Highways
 -  US Routes
 -  Major Roads
 -  Local Roads
- Background**
 -  Aerial Photography
- Other**
 -  C
 -  C/D
 -  D
 -  Not rated or not available

MAP INFORMATION

The soil surveys that comprise your AOI were mapped at 1:24,000.

Warning: Soil Map may not be valid at this scale.
 Enlargement of maps beyond the scale of mapping can cause misunderstanding of the detail of mapping and accuracy of soil line placement. The maps do not show the small areas of contrasting soils that could have been shown at a more detailed scale.

Please rely on the bar scale on each map sheet for map measurements.

Source of Map: Natural Resources Conservation Service
 Web Soil Survey URL:
 Coordinate System: Web Mercator (EPSG:3857)

Maps from the Web Soil Survey are based on the Web Mercator projection, which preserves direction and shape but distorts distance and area. A projection that preserves area, such as the Albers equal-area conic projection, should be used if more accurate calculations of distance or area are required.

This product is generated from the USDA-NRCS certified data as of the version date(s) listed below.

Soil Survey Area: Bexar County, Texas
 Survey Area Data: Version 26, Aug 24, 2022

Soil map units are labeled (as space allows) for map scales 1:50,000 or larger.

Date(s) aerial images were photographed: Dec 3, 2020—Dec 9, 2020

The orthophoto or other base map on which the soil lines were compiled and digitized probably differs from the background imagery displayed on these maps. As a result, some minor shifting of map unit boundaries may be evident.

Hydrologic Soil Group

Map unit symbol	Map unit name	Rating	Acres in AOI	Percent of AOI
OrB	Laparita clay loam, 1 to 3 percent slopes	C	3.0	15.2%
SaB	San Antonio clay loam, 1 to 3 percent slopes	C	16.4	84.8%
Totals for Area of Interest			19.4	100.0%

Description

Hydrologic soil groups are based on estimates of runoff potential. Soils are assigned to one of four groups according to the rate of water infiltration when the soils are not protected by vegetation, are thoroughly wet, and receive precipitation from long-duration storms.

The soils in the United States are assigned to four groups (A, B, C, and D) and three dual classes (A/D, B/D, and C/D). The groups are defined as follows:

Group A. Soils having a high infiltration rate (low runoff potential) when thoroughly wet. These consist mainly of deep, well drained to excessively drained sands or gravelly sands. These soils have a high rate of water transmission.

Group B. Soils having a moderate infiltration rate when thoroughly wet. These consist chiefly of moderately deep or deep, moderately well drained or well drained soils that have moderately fine texture to moderately coarse texture. These soils have a moderate rate of water transmission.

Group C. Soils having a slow infiltration rate when thoroughly wet. These consist chiefly of soils having a layer that impedes the downward movement of water or soils of moderately fine texture or fine texture. These soils have a slow rate of water transmission.

Group D. Soils having a very slow infiltration rate (high runoff potential) when thoroughly wet. These consist chiefly of clays that have a high shrink-swell potential, soils that have a high water table, soils that have a claypan or clay layer at or near the surface, and soils that are shallow over nearly impervious material. These soils have a very slow rate of water transmission.

If a soil is assigned to a dual hydrologic group (A/D, B/D, or C/D), the first letter is for drained areas and the second is for undrained areas. Only the soils that in their natural condition are in group D are assigned to dual classes.

Rating Options

Aggregation Method: Dominant Condition

"Straight row" and the hydrologic condition is "Good", then the SCS Curve Numbers will range from 67 to 89, depending on the soil group.

Land Use Description	Hydrologic Soil Group			
	A	B	C	D
Residential:				
1/8 acre or less average lots (65% imperv.)	77	85	90	92
1/4 acre average lots (38% impervious)	61	75	83	87
1/3 acre average lots (35% impervious)	57	72	81	86
1/2 acre average lots (25% impervious)	54	70	80	85
1 acre average lots (20% impervious)	51	68	79	84
Paved parking lots, roofs, driveways, etc.	98	98	98	98
Streets and Roads:				
Paved with curbs and storm sewers	98	98	98	98
gravel	76	85	89	91
dirt	72	82	87	89
Commercial & Business Areas (85% Impervious)	89	92	94	95
Industrial Districts (72% Impervious)	81	88	91	93
Open Spaces, Lawns, Parks, Golf Courses, Cemeteries, etc.:				
good condition grass cover on 75% or more	39	61	74	80
fair condition grass cover on 50% to 75%	49	69	79	84

TABLE 5.2 Values of SCS Curve Number for Urban and Suburban Areas

Source: [McCuen, 1982].

The values in this table are "adjusted" to account for the effects of urbanization. These adjusted values already account for the effects of impervious cover in the watershed. Therefore, the "Percent Impervious Cover in Watershed" value should normally be set to zero (0) if the adjusted Curve Numbers listed in this table are used.

This is **not** the method recommended for use in HEC-1.

HYDROGRAPH DEVELOPMENT INFORMATION

HYDROGRAPH DEVELOPMENT INFORMATION

Offsite and Overland Flow Areas

The hydrographs for the drainage areas were developed using the Soil Conservation Service (SCS) unit hydrograph method. The National Resources Conservation Service (NRCS) method has been used to estimate SCS parameters. SCS parameter estimations are provided on the following pages.

Drainage Areas

The drainage areas used for this analysis are shown on Sheet IIIB-C-16. The routing scheme is shown in the HEC-HMS output file.

SAN ANTONIO TRANSFER STATION
0601-012-11
SCS UNIT HYDROGRAPH DATA

SCS Unit Hydrograph Coefficients (NRCS Method)

Existing Conditions

Drainage Area	Area (acres)	I (%)	Manning "n"	CN	Sheet Flow				Shallow Concentrated Flow				t _{total} min	t _{lag} min	
					Length ft	P ₂ in	Slope	t _{sheet} hr	Paved?	Length ft	Slope	Velocity ft/sec			t _{shallow} hr
DA1	2.22	25	0.15	80	300	4.44	0.0100	0.333	N	363	0.0055	1.1966	0.084	25.0	15.0
DA2	5.29	2	0.15	74	50	4.44	0.0200	0.083	N	830	0.0072	1.3691	0.168	15.1	9.1
O1	1.58	2	0.15	74	250	4.44	0.0040	0.333	N	--	--	--	--	20.0	12.0
O2	13.40	28	0.15	81	300	4.44	0.0133	0.333	N	646	0.0093	1.5560	0.115	26.9	16.2
O1+DA2	6.87	2	0.15	74	300	4.44	0.0033	0.333	N	830	0.0060	1.2498	0.184	31.1	18.6

t_r = surface runoff to unit hydrograph peak (min)

I = impervious cover within the watershed (%)

t_{lag} = watershed lag time (min)

P₂ = 2-year, 24-hour rainfall depth (in)

t_{sheet} = Time for the sheet flow (Initial 300 ft of the flow length) (Per "San Antonio Storm Water Drainage Manual", maximum overland flow is 20 min and its minimum is 5 min)

t_{shallow} = Time for the shallow concentrated flow (flow length after initial 300 ft)

SCS Unit Hydrograph uses lag time (t_{lag}) for flood wave and watershed storage conditions.

Dainage area DA1 is used for example.

Estimated Watershed specific parameters

A =	2.22	acres	watershed area
L =	300.00	feet	maximun flow length with this watershed
S =	0.01	feet/feet	watershed slope
I =	25	percent (%)	watershed imperviousness
n =	0.15		Manning's coefficient
P ₂ =	4.44	in	2-Year, 24-Hour rainfall depth

The SCS UH lag can be estimated via calibration for gaged headwater subwatersheds. Time of concentration is a quasi-physically based parameter that can be estimated as:

$$t_{total} = t_{sheet} + t_{shallow} + t_{channel}$$

Calculate T_{sheet} : Sum of travel time in sheet flow segments over the watershed land surface

$$t_{sheet} = 0.007(nL)^{0.8} / (P_2^{0.5} S^{0.4})$$

$$t_{sheet} = 0.007(0.15 * 300)^{0.8} / ((4.44^{0.5})(0.01^{0.4}))$$

$$t_{sheet} = 0.441 \quad \text{hr}$$

$$t_{sheet} = 20.0 \quad \text{min} \quad (\text{Per "San Antonio Storm Water Srainage Manual ", maximum overland flow is 20 min and its minimum is 5 min})$$

Calculate $T_{shallow}$: Sum of travel time in shallow flow segments, down streets, in gutters, or in shallow rills and rivulets

$$t_{shallow} = L/V \quad (V \text{ is flow velocity})$$

$$V = 16.1345(S^{0.5}) \quad \text{for unpaved surface}$$

$$V = 20.3282(S^{0.5}) \quad \text{for paved surface}$$

DA1 is An unpaved surface.

$$t_{shallow} = 363 / (3600 * 16.1345(0.01^{0.5}))$$

$$t_{shallow} = 0.084 \quad \text{hr}$$

$$t_{shallow} = 5.0 \quad \text{min}$$

Calculate $T_{channel}$: Sum of travel time in channel segments.

There is no channel flow in this drainage area.

$$t_{total} = 25.0 \quad \text{min}$$

$$t_{lag} = 0.6 t_{total}$$

$$t_{lag} = 15.0 \quad \text{min}$$

Travel time (T_t) is the time it takes water to travel from one location to another in a watershed. T_t is a component of time of concentration (T_c), which is the time for runoff to travel from the hydraulically most distant point of the watershed to a point of interest within the watershed. T_c is computed by summing all the travel times for consecutive components of the drainage conveyance system.

T_c influences the shape and peak of the runoff hydrograph. Urbanization usually decreases T_c , thereby increasing the peak discharge. But T_c can be increased as a result of (a) ponding behind small or inadequate drainage systems, including storm drain inlets and road culverts, or (b) reduction of land slope through grading.

Factors affecting time of concentration and travel time

Surface roughness

One of the most significant effects of urban development on flow velocity is less retardance to flow. That is, undeveloped areas with very slow and shallow overland flow through vegetation become modified by urban development: the flow is then delivered to streets, gutters, and storm sewers that transport runoff downstream more rapidly. Travel time through the watershed is generally decreased.

Channel shape and flow patterns

In small non-urban watersheds, much of the travel time results from overland flow in upstream areas. Typically, urbanization reduces overland flow lengths by conveying storm runoff into a channel as soon as possible. Since channel designs have efficient hydraulic characteristics, runoff flow velocity increases and travel time decreases.

Slope

Slopes may be increased or decreased by urbanization, depending on the extent of site grading or the extent to which storm sewers and street ditches are used in the design of the water management system. Slope will tend to increase when channels are straightened and decrease when overland flow is directed through storm sewers, street gutters, and diversions.

Computation of travel time and time of concentration

Water moves through a watershed as sheet flow, shallow concentrated flow, open channel flow, or some combination of these. The type that occurs is a function of the conveyance system and is best determined by field inspection.

Travel time (T_t) is the ratio of flow length to flow velocity:

$$T_t = \frac{L}{3600V} \quad [\text{eq. 3-1}]$$

where:

T_t = travel time (hr)

L = flow length (ft)

V = average velocity (ft/s)

3600 = conversion factor from seconds to hours.

Time of concentration (T_c) is the sum of T_t values for the various consecutive flow segments:

$$T_c = T_{t_1} + T_{t_2} + \dots + T_{t_m} \quad [\text{eq. 3-2}]$$

where:

T_c = time of concentration (hr)

m = number of flow segments

Sheet flow

Sheet flow is flow over plane surfaces. It usually occurs in the headwater of streams. With sheet flow, the friction value (Manning's n) is an effective roughness coefficient that includes the effect of raindrop impact; drag over the plane surface; obstacles such as litter, crop ridges, and rocks; and erosion and transportation of sediment. These n values are for very shallow flow depths of about 0.1 foot or so. Table 3-1 gives Manning's n values for sheet flow for various surface conditions.

Table 3-1 Roughness coefficients (Manning's n) for sheet flow

Surface description	n ^{1/}
Smooth surfaces (concrete, asphalt, gravel, or bare soil)	0.011
Fallow (no residue)	0.05
Cultivated soils:	
Residue cover ≤20%	0.06
Residue cover >20%	0.17
Grass:	
Short grass prairie	0.15
Dense grasses ^{2/}	0.24
Bermudagrass	0.41
Range (natural)	0.13
Woods: ^{3/}	
Light underbrush	0.40
Dense underbrush	0.80

¹ The n values are a composite of information compiled by Engman (1986).

² Includes species such as weeping lovegrass, bluegrass, buffalo grass, blue grama grass, and native grass mixtures.

³ When selecting n , consider cover to a height of about 0.1 ft. This is the only part of the plant cover that will obstruct sheet flow.

For sheet flow of less than 300 feet, use Manning's kinematic solution (Overtop and Meadows 1976) to compute T_t :

$$T_t = \frac{0.007(nL)^{0.8}}{(P_2)^{0.5} s^{0.4}} \quad [\text{eq. 3-3}]$$

where:

- T_t = travel time (hr),
- n = Manning's roughness coefficient (table 3-1)
- L = flow length (ft)
- P_2 = 2-year, 24-hour rainfall (in)
- s = slope of hydraulic grade line (land slope, ft/ft)

This simplified form of the Manning's kinematic solution is based on the following: (1) shallow steady uniform flow, (2) constant intensity of rainfall excess (that part of a rain available for runoff), (3) rainfall duration of 24 hours, and (4) minor effect of infiltration on travel time. Rainfall depth can be obtained from appendix B.

Shallow concentrated flow

After a maximum of 300 feet, sheet flow usually becomes shallow concentrated flow. The average velocity for this flow can be determined from figure 3-1, in which average velocity is a function of watercourse slope and type of channel. For slopes less than 0.005 ft/ft, use equations given in appendix F for figure 3-1. Tillage can affect the direction of shallow concentrated flow. Flow may not always be directly down the watershed slope if tillage runs across the slope.

After determining average velocity in figure 3-1, use equation 3-1 to estimate travel time for the shallow concentrated flow segment.

Open channels

Open channels are assumed to begin where surveyed cross section information has been obtained, where channels are visible on aerial photographs, or where blue lines (indicating streams) appear on United States Geological Survey (USGS) quadrangle sheets. Manning's equation or water surface profile information can be used to estimate average flow velocity. Average flow velocity is usually determined for bank-full elevation.

**EXISTING CONDITION HEC-HMS
ANALYSIS DRAINAGE AREAS**

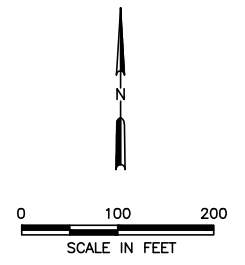
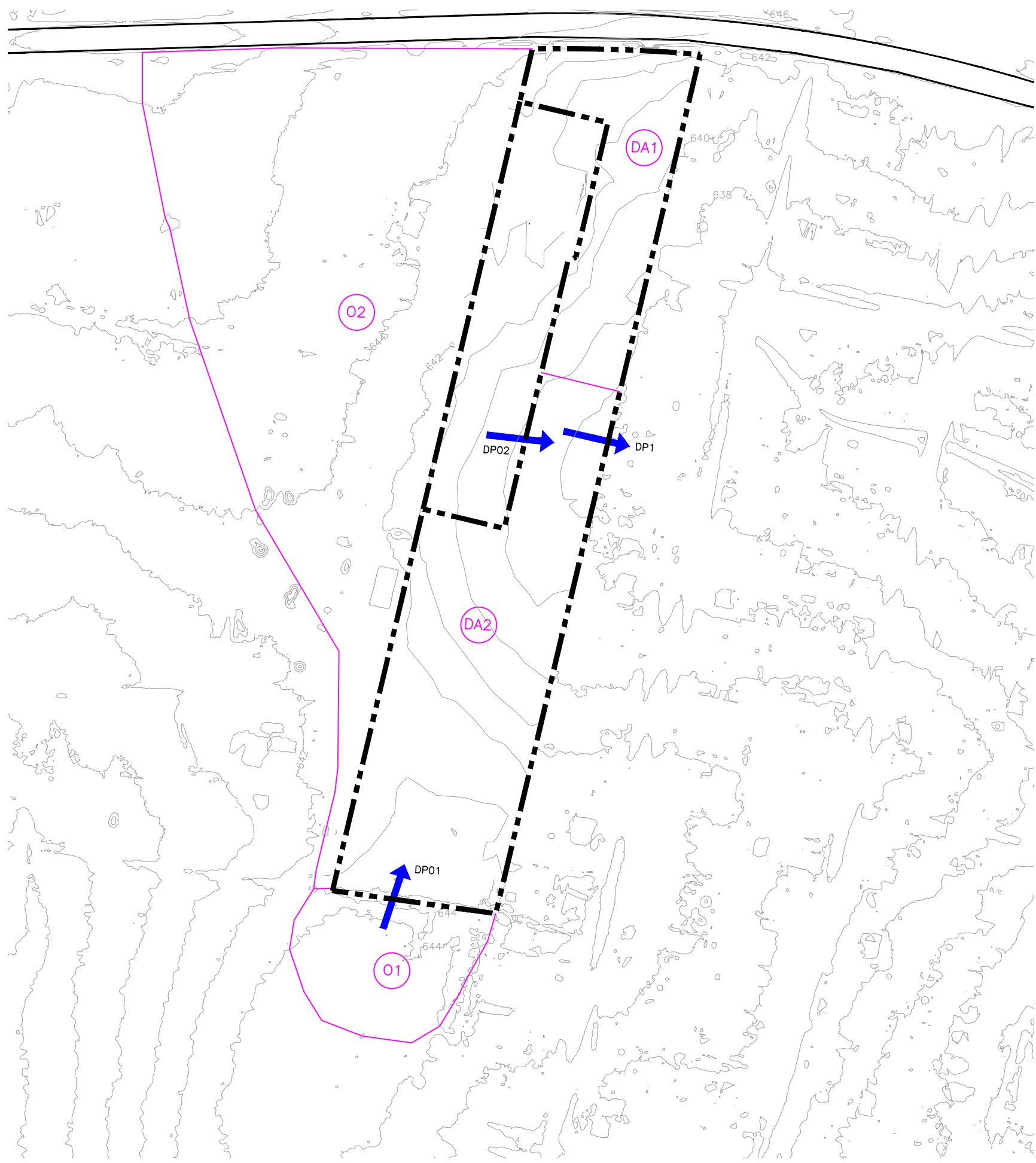

LEGEND

- PERMIT BOUNDARY
- PROPERTY BOUNDARY
- EXISTING CONTOUR
- DRAINAGE AREA
- DRAINAGE LOCATIONS
- DRAINAGE AREA DESIGNATION

NOTES:
 1. THE EXISTING CONTOURS PROVIDED BY TEXAS RESOURCE INFORMATION SYSTEM (TNRIS) BEXAR AND TRAVIS COUNTIES LIDAR, 2022.

EXISTING CONDITION DRAINAGE AREAS	
DRAINAGE AREA	AREA (ACRES)
O1	1.58
O2	13.40
DA1	2.22
DA2	5.29

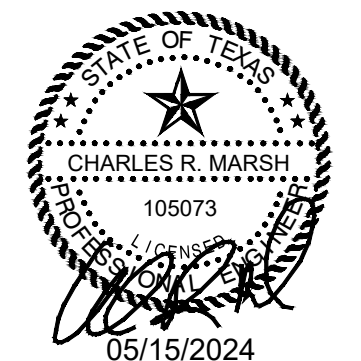

Tech. Complete App. - 407

<input type="checkbox"/> 90% REVIEW <input checked="" type="checkbox"/> FOR PERMITTING PURPOSES ONLY <input type="checkbox"/> ISSUED FOR CONSTRUCTION	PREPARED FOR WASTE CONNECTIONS LONE STAR, INC.	TYPE V PERMIT APPLICATION EXISTING DRAINAGE CONDITIONS SAN ANTONIO TRANSFER STATION BEXAR COUNTY, TEXAS						
	DATE: 01/2024 FILE: 0601-012-11 CAD: IIB-C-16 PERMITTED DRNG CONLDWG		DRAWN BY: RAA DESIGN BY: MB REVIEWED BY: CRM					
Weaver Consultants Group TBPE REGISTRATION NO. F-3727		REVISIONS <table border="1"> <thead> <tr> <th>NO.</th> <th>DATE</th> <th>DESCRIPTION</th> </tr> </thead> <tbody> <tr> <td>1</td> <td>05/2024</td> <td>PERMIT MODIFICATION</td> </tr> </tbody> </table>	NO.	DATE	DESCRIPTION	1	05/2024	PERMIT MODIFICATION
NO.	DATE	DESCRIPTION						
1	05/2024	PERMIT MODIFICATION						
		WWW.WCGRP.COM SHEET IIB-C-16						

C:\0601\12\TYPE V PERMIT APP\PART IIB\IIB-C-16 Permitted Drainage Conditions.dwg, cmar.sh, 1:2

**HEC-HMS OUTPUT – EXISTING CONDITION
25-YEAR, 24-HOUR STORM EVENT**

Project: San_Antonio_Transfer_Station

Simulation Run: Existing - 25 Year

Simulation Start: 1 January 2023, 01:00

Simulation End: 3 January 2023, 13:00

HMS Version: 4.11

Executed: 28 September 2023, 14:00

Global Parameter Summary - Subbasin

Area (MI²)

Element Name	Area (MI ²)
O2	0.02
O1 + DA2	0.01
O1	0
Da1	0

Downstream

Element Name	Downstream
O2	Dp1
O1 + DA2	Dp1
Da1	Dp1

Loss Rate: Scs

Element Name	Percent Impervious Area	Curve Number
O2	28	81
O1 + DA2	2	74
O1	2	74
Da1	25	80

Transform: Scs

Element Name	Lag	Unitgraph Type
O2	16.2	Standard
O1 + DA2	18.6	Standard
O1	12	Standard
Da1	15	Standard

Global Results Summary

Hydrologic Element	Drainage Area (MI ²)	Peak Discharge (CFS)	Time of Peak	Volume (IN)
O2	0.02	65.5	01Jan2023, 13:18	6.65
O1 + DA2	0.01	26.11	01Jan2023, 13:21	5.25
O1	0	7.55	01Jan2023, 13:14	5.25
Da1	0	11.18	01Jan2023, 13:16	6.5
Dp1	0.04	102.18	01Jan2023, 13:18	6.21

Subbasin: O2

Area (MI²) : 0.02

Downstream : Dp1

Loss Rate: SCS

Percent Impervious Area	28
Curve Number	81

Transform: SCS

Lag	16.2
Unitgraph Type	Standard

Results: O2

Peak Discharge (CFS)	65.5
Time of Peak Discharge	01Jan2023, 13:18
Volume (IN)	6.65
Precipitation Volume (AC - FT)	9.24
Loss Volume (AC - FT)	1.82
Excess Volume (AC - FT)	7.42
Direct Runoff Volume (AC - FT)	7.42
Baseflow Volume (AC - FT)	0

Precipitation and Outflow

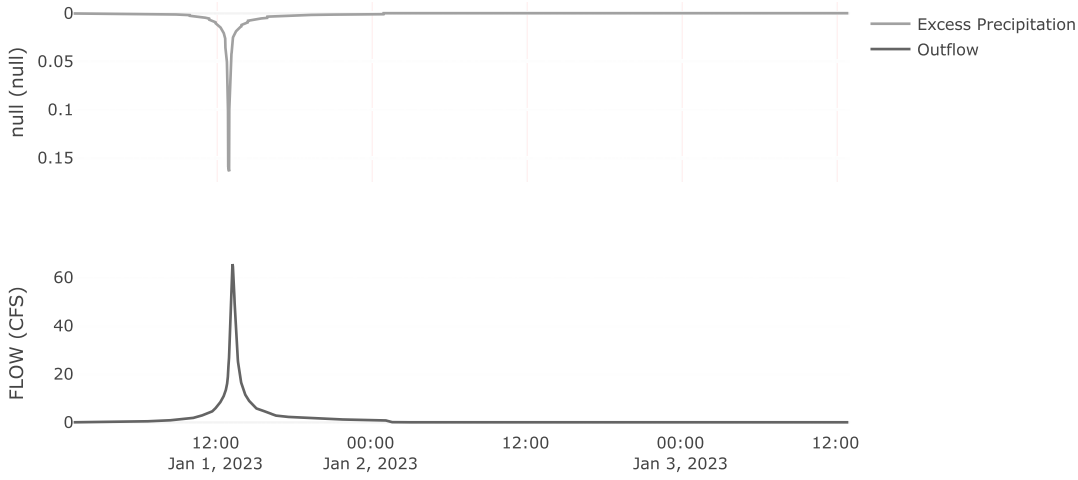

Cumulative Outflow

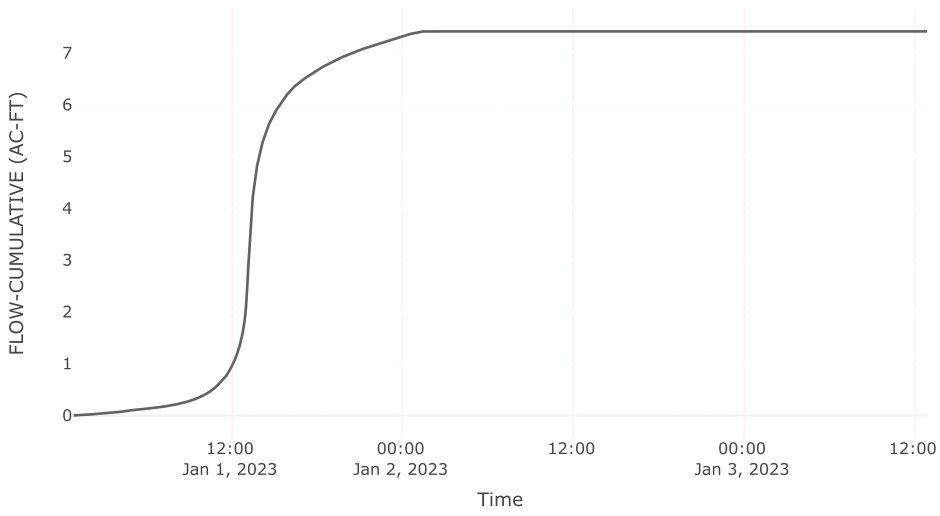

Subbasin: OI+DA2

Area (MI²) : 0.01

Downstream : Dp1

Loss Rate: SCS

Percent Impervious Area	2
Curve Number	74

Transform: SCS

Lag	18.6
Unitgraph Type	Standard

Results: OI+DA2

Peak Discharge (CFS)	26.11
Time of Peak Discharge	01Jan2023, 13:21
Volume (IN)	5.25
Precipitation Volume (AC - FT)	4.73
Loss Volume (AC - FT)	1.74
Excess Volume (AC - FT)	2.99
Direct Runoff Volume (AC - FT)	2.99
Baseflow Volume (AC - FT)	0

Precipitation and Outflow

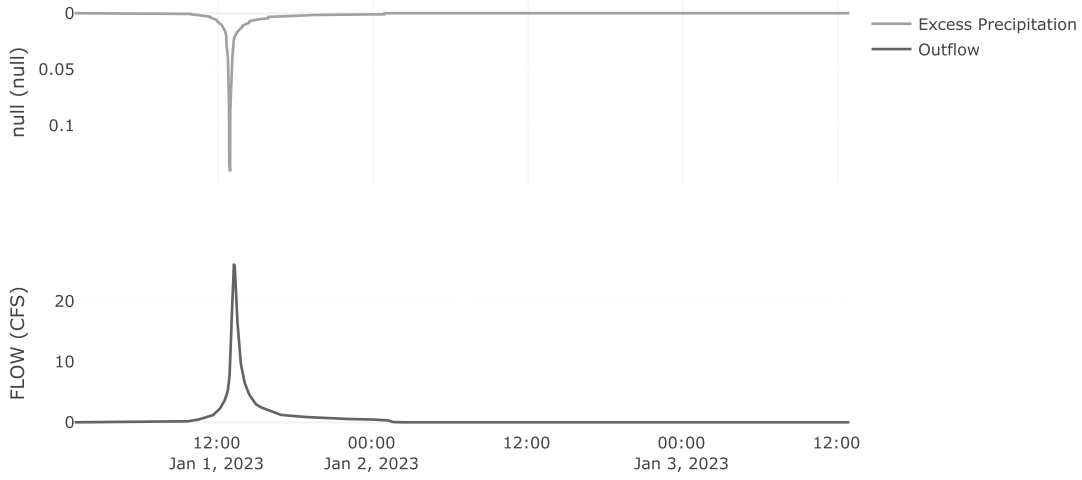

Cumulative Outflow

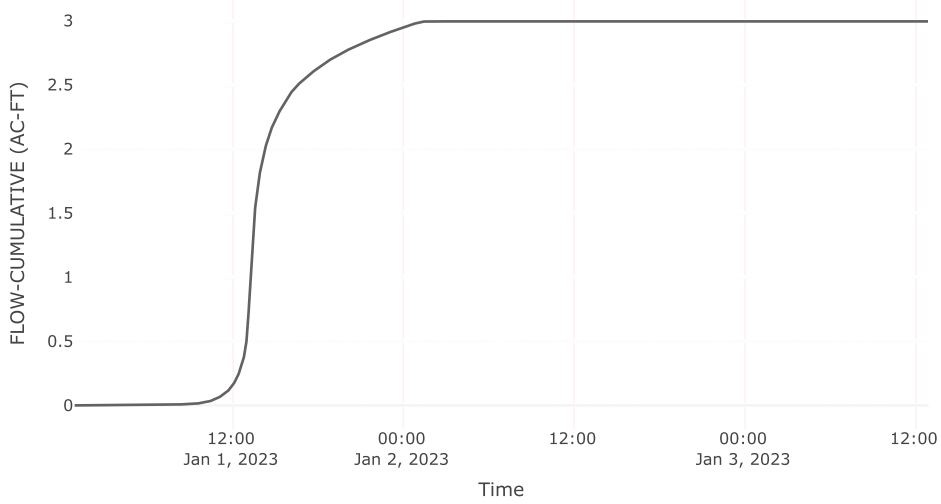

Subbasin: O1

Area (MI²): 0

Loss Rate: Scs

Percent Impervious Area	2
Curve Number	74

Transform: Scs

Lag	12
Unitgraph Type	Standard

Results: O1

Peak Discharge (CFS)	7.55
Time of Peak Discharge	01Jan2023, 13:14
Volume (IN)	5.25
Precipitation Volume (AC - FT)	1.11
Loss Volume (AC - FT)	0.41
Excess Volume (AC - FT)	0.7
Direct Runoff Volume (AC - FT)	0.7
Baseflow Volume (AC - FT)	0

Precipitation and Outflow

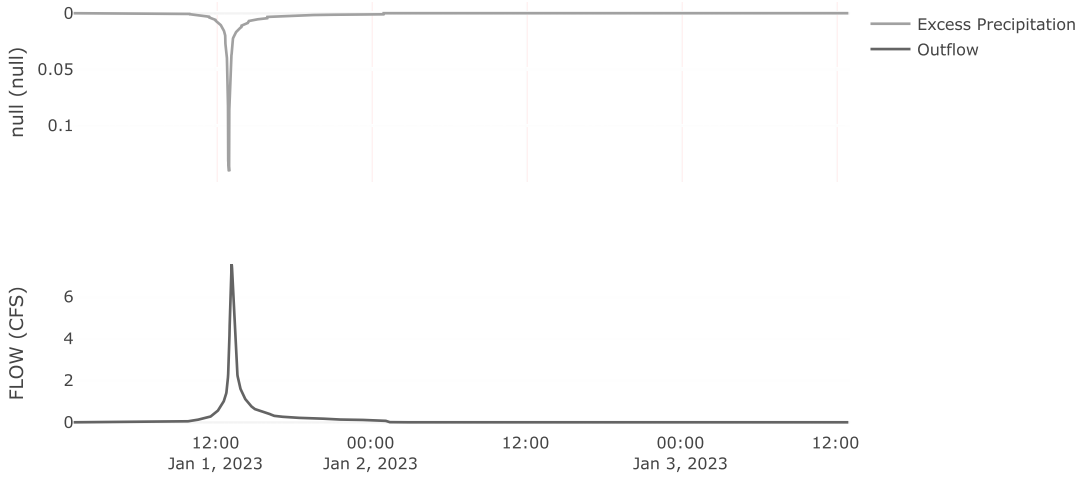

Cumulative Outflow

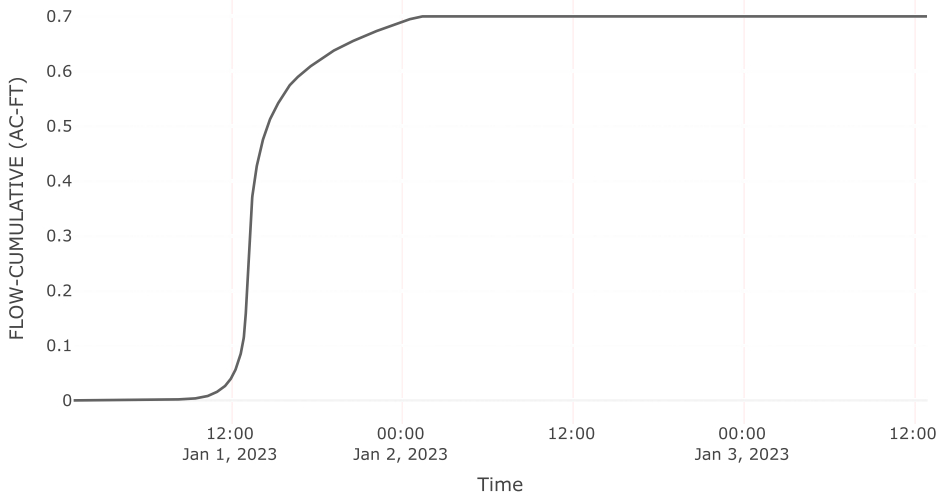

Subbasin: DA1

Area (MI²) : 0

Downstream : Dp1

Loss Rate: SCS

Percent Impervious Area	25
Curve Number	80

Transform: SCS

Lag	15
Unitgraph Type	Standard

Results: DA1

Peak Discharge (CFS)	11.18
Time of Peak Discharge	01Jan2023, 13:16
Volume (IN)	6.5
Precipitation Volume (AC - FT)	1.55
Loss Volume (AC - FT)	0.33
Excess Volume (AC - FT)	1.21
Direct Runoff Volume (AC - FT)	1.21
Baseflow Volume (AC - FT)	0

Precipitation and Outflow

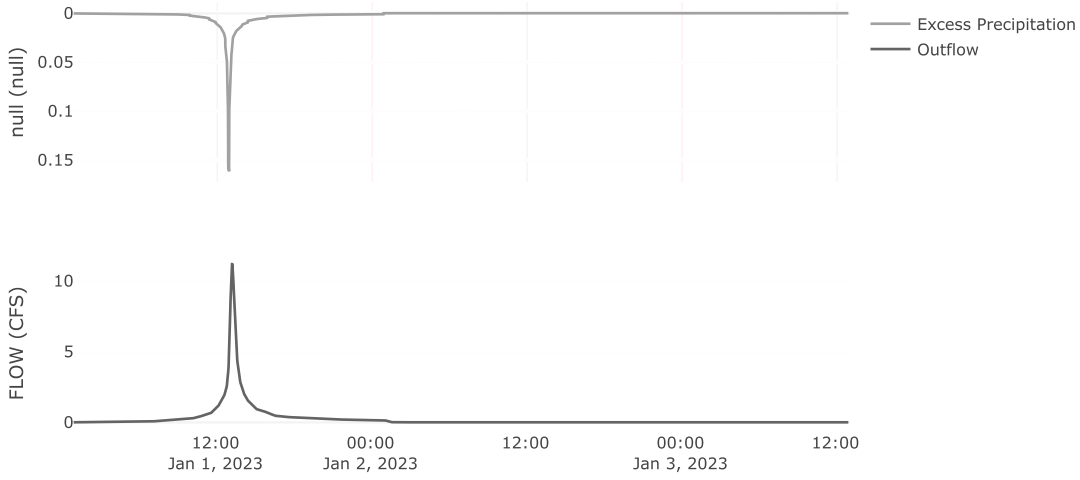

Cumulative Outflow

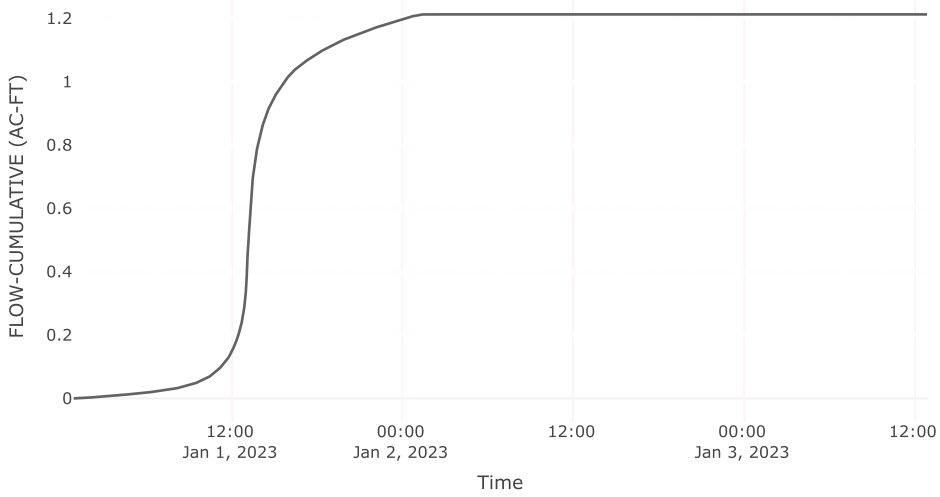

Junction: DP1

Results: DP1

Peak Discharge (CFS)	102.18
Time of Peak Discharge	01 Jan 2023, 13:18
Volume (IN)	6.21

Combined Inflow

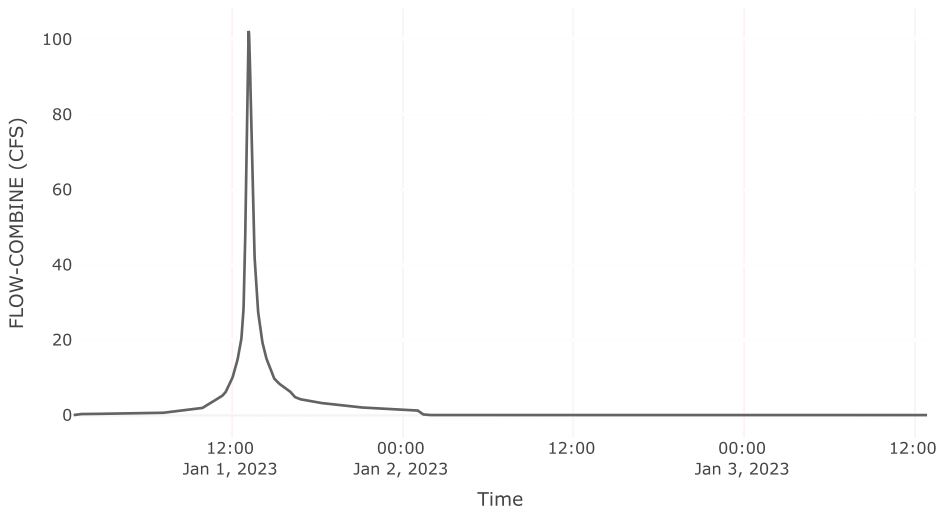

Cumulative Outflow

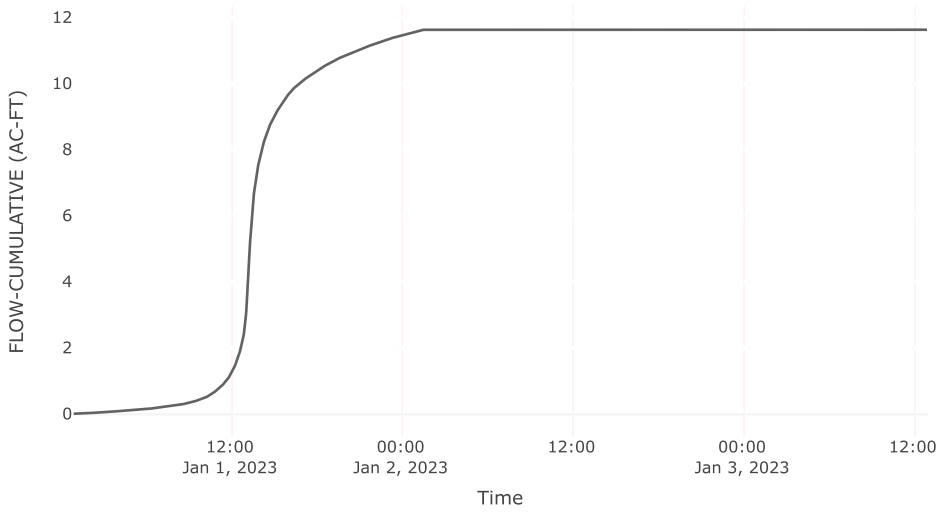

Outflow

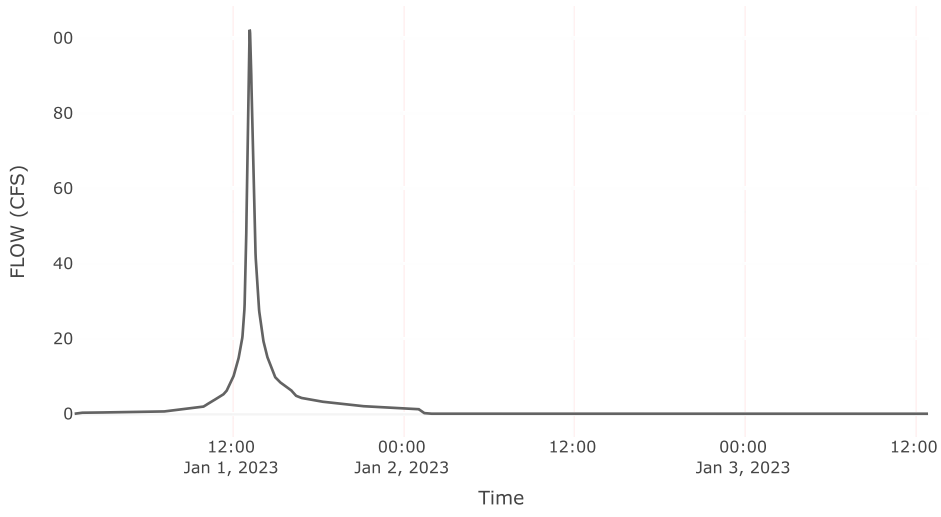

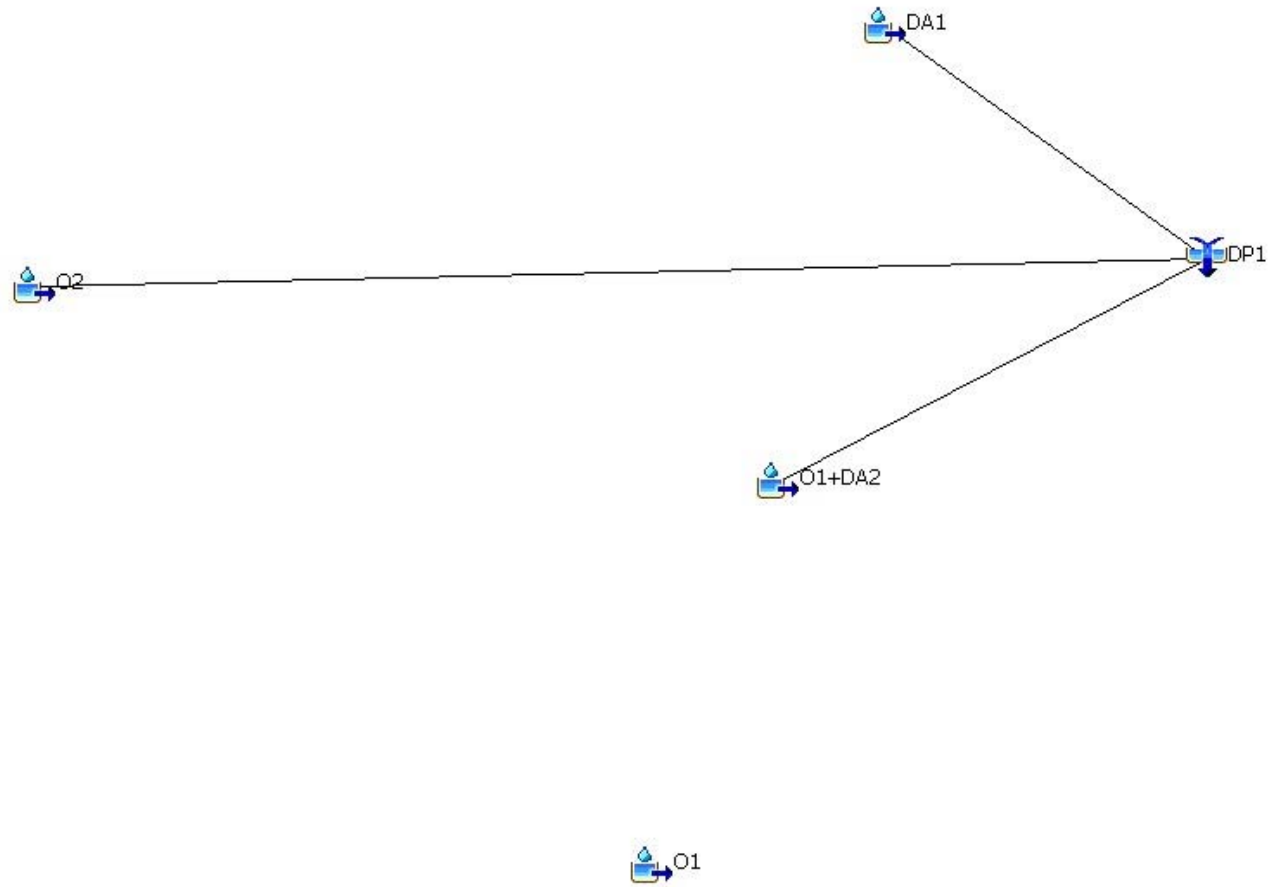

VOLUME CALCULATIONS

EXCESS RAINFALL VOLUME CALCULATION

The volume generated by the site and the surrounding properties is calculated for the 25-year, 24-hour storm event. A summary of the design information that is included in this appendix and related appendices are listed below.

- Excess rainfall and drainage areas used in the volume calculations were obtained from the HEC-HMS analysis located in Appendix IIIB-C (existing).
- Existing condition volume information is summarized on page IIIB-C-32.

Required: Determine the 25-year 24-hour storm volume generated by the site and offsite areas using the excess rainfall calculated in the HEC-HMS analysis of the existing expansion site conditions.

Method: Use the excess rainfall data generated by the HEC-HMS analysis (pages IIIB-A-18 through IIIB-A-29) to determine the volume produced by the site for the existing expansion conditions.

Existing Expansion Conditions

1. Total Volume at DPO1

Area No.	Area (ac)	Volume (in)	Volume (ac-ft)
O1	1.58	5.25	0.69
Total Volume Discharging At DPO1			0.69

2. Total Volume at DPO2

Area No.	Area (ac)	Volume (in)	Volume (ac-ft)
O2	13.40	6.65	7.43
Total Volume Discharging At DPO2			7.43

3. Total Volume at DP1

Area No.	Area (ac)	Volume (in)	Volume (ac-ft)
DA1	2.22	6.50	1.20
O1+DA2	6.87	5.25	3.01
O2	13.40	6.65	7.43
Total Volume Discharging At DP1			11.63

VELOCITY CALCULATIONS

Required: Determine the flow velocities entering and exiting the permit boundary using HYDROCALC HYDRAULICS (Version 2.0.1 1996-2010) for the flows calculated for the 25-year 24-hour storm event in the HEC-1 analysis.

Method:
1. Use the flow data generated by the HEC-HMS analysis to determine velocity of runoff entering and exiting the Transfer Station permit boundary.

1. Flow Velocity entering the Transfer Station permit boundary
Flow for the 25-year 24-hour storm event was obtained from the HEC-HMS file included in this Appendix.

DPO 1

$$Q_{25} = 7.55 \text{ cfs}$$

Storm Year	Flow Rate (cfs)	Bottom Slope (ft/ft)	n-value	Side Slope (left)	Side Slope (right)	Bottom Width (ft)	Normal Depth (ft)	Flow Vel. (fps)
25	7.55	0.004	0.04	100	100	287	0.07	0.39

Note: Calculations were performed using the HYDROCALC HYDRAULICS for Windows program developed by Dodson and Associates (Version 2.01, 1996-2010).

2. Flow Velocity entering the Transfer Station permit boundary
Flow for the 25-year 24-hour storm event was obtained from the HEC-HMS file included in this Appendix.

DPO2

$$Q_{25} = 65.50 \text{ cfs}$$

Storm Year	Flow Rate (cfs)	Bottom Slope (ft/ft)	n-value	Side Slope (left)	Side Slope (right)	Bottom Width (ft)	Normal Depth (ft)	Flow Vel. (fps)
25	65.5	0.008	0.04	100	100	729	0.11	0.78

Note: Calculations were performed using the HYDROCALC HYDRAULICS for Windows program developed by Dodson and Associates (Version 2.01, 1996-2010).

3. Flow Velocity exiting the Transfer Station permit boundary
Flow for the 25-year 24-hour storm event was obtained from the HEC-HMS file included in this Appendix.

DP 1

$$Q_{25} = 102.18 \text{ cfs}$$

Storm Year	Flow Rate (cfs)	Bottom Slope (ft/ft)	n-value	Side Slope (left)	Side Slope (right)	Bottom Width (ft)	Normal Depth (ft)	Flow Vel. (fps)
25	102.18	0.005	0.04	100	100	100	0.50	1.37

Note: Calculations were performed using the HYDROCALC HYDRAULICS for Windows program developed by Dodson and Associates (Version 2.01, 1996-2010).

**SAN ANTONIO STATION
BEXAR COUNTY, TEXAS
TCEQ PERMIT NO. MSW-2420
TYPE V PERMIT APPLICATION**

**PART III
FACILITY DESIGN REPORT
APPENDIX IIIC
CLOSURE PLAN**

Prepared for
Waste Connections Lone Star, Inc.
January 2024
Revised May 2024



Prepared by
Weaver Consultants Group, LLC
TBPE Registration No. F-3727
6420 Southwest Blvd., Suite 206
Fort Worth, Texas 76109
817-735-9770

Project No. 0601-012-11-01

This document is issued for permitting purposes only.

CONTENTS

1	INTRODUCTION	IIC-1
2	CLOSURE REQUIREMENTS	IIC-2
3	CERTIFICATION OF FINAL FACILITY CLOSURE	IIC-4
4	POSTCLOSURE LAND USE	IIC-5



1 INTRODUCTION

This Closure Plan has been prepared for the San Antonio Transfer Station and is consistent with 30 TAC §330.63(h) and §330.459. Section 2 of this Closure Plan describes the steps necessary to close the facility at any point during its active life and Section 3 of this Closure Plan discusses post-closure land use of the site. Post-closure maintenance of the site is not required as all wastes and waste residues will be removed during closure in accordance with 30 TAC §330.459(a).

WCLSI shall, unless specifically authorized by the commission, close the facility in accordance with the closure provisions of the Permit application.

2 CLOSURE REQUIREMENTS

2.1 Title 30 TAC §330.459 and 30 TAC §330.457 Closure Requirements

At the time of closure, the site will remove all waste, waste residues, and any recovered materials. The transfer station structure, pad, walls and associated units will be decontaminated. All material on-site, whether in process or processed will be evacuated to an authorized facility, and the tipping floors, processing areas, and post-processing areas will be disinfected by washing down with industrial cleaners. The operator shall then complete the closure activities for the unit in accordance with the approved plan with 180 days of initiation of closure activities. The operator shall will begin closure no later than 30 days after final receipt of waste.

2.2 Title 30 TAC §330.461 Certification of Final Facility Closure

No later than 90 days prior to the initiation of final closure, the site will, through a public notice in the newspaper(s) of largest circulation in the vicinity of the facility, provide public notice for final facility closure. This notice will include the name, address, and physical location of the facility, the permit number, and the last day of intended receipt of materials for processing at the facility. The site will also make available an adequate number of copies of the approved Closure Plan for public review. The owner/operator will also provide written notification to the TCEQ of the intent to close the facility and place this Notice of Intent in the site operating record.

Initiation of closure activities for the facility will begin after the date on which the facility receives the known final receipt of waste to be processed.

The following steps will be taken:

- Notify the TCEQ of when closure will be initiated.
- Post a minimum of one sign at the main entrance and all other frequently used points of access for the facility notifying all persons who may utilize the facility of the date of closing for the facility and the prohibition against further receipt of waste materials after the stated date.

- Install suitable barriers to all gates or access points or alternatively, fence around the entire waste processing area, to adequately prevent the unauthorized dumping of solid waste at the closed facility.
- Remove waste, waste residues, contaminated water, and any recovered materials.
- Dismantle and remove or decontaminate facility units.
- Disinfect tipping floors, processing area, and post-processing areas.
- Wash transfer station tipping floors and any surfaces that have been in contact with waste.
- Perform facility inspection and prepare certification of closure. The certification shall be signed by an independent Texas licensed professional engineer, verifying that final facility closure has been completed in accordance with the approved closure plan. The submittal to the TCEQ Executive Director shall include all applicable documentation necessary for certification of final facility closure.
- If there is evidence of a release from the transfer station, the Executive Director may require an investigation into the nature and extent of the release and an assessment of measures necessary to correct an impact to groundwater. If hazardous constituents are measured in groundwater, exceeding the limits prescribed in 30 TAC §330.409, a characterization of the groundwater constituents shall be prepared.

3 CERTIFICATION OF FINAL FACILITY CLOSURE

Following completion of all final closure activities for the transfer station, WCLSI will submit within 10 days to the TCEQ Executive Director for review and approval a documented certification signed by an independent Texas licensed professional engineer, verifying that final closure has been completed in accordance with the approved Closure Plan and the applicable rule provisions of 30 TAC Chapter 330 Subchapter K. The submittal to the TCEQ Executive Director shall include all applicable documentation necessary for certification of final closure.

Following receipt of the required final closure documents, as applicable, the TCEQ regional office will conduct an inspection and provide a report verifying proper closure of the facility according to the approved Closure Plan before termination of operation and closure of the facility will be acknowledged and the facility deemed properly closed.

Since the facility does not require post-closure care, a request for voluntary revocation of the facility permit will be submitted to the executive director.

4 POSTCLOSURE LAND USE

All wastes and waste residues will be removed from the facility upon closure. At the time of closure, the TCEQ Executive Director will be provided with documentation of waste removal and a request will be made that there be no restrictions to the postclosure use of the facility related to its previous use as a municipal solid waste transfer station facility.

**SAN ANTONIO TRANSFER STATION
BEXAR COUNTY, TEXAS
TCEQ PERMIT NO. MSW-2420
TYPE V PERMIT APPLICATION
PART III
SITE PLAN AND DESIGN CRITERIA
APPENDIX IIID
COST ESTIMATE FOR CLOSURE**

Prepared for
Waste Connections Lone Star, Inc.
January 2024
Revised May 2024



Prepared by
Weaver Consultants Group, LLC
TBPE Registration No. F-3727
6420 Southwest Blvd., Suite 206
Fort Worth, Texas 76109
817-735-9770

Project No. 0601-012-11-01

This document is issued for permitting purposes only.

CONTENTS

1	INTRODUCTION	IIID-1
2	CLOSURE COST ESTIMATE	IIID-2
3	COST ESTIMATE ADJUSTMENTS	IIID-4

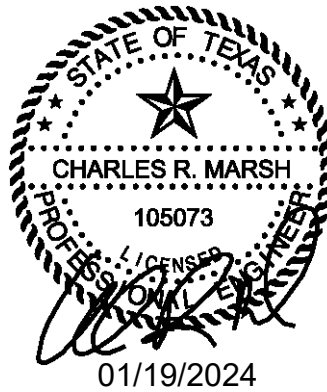

1 INTRODUCTION

This Cost Estimate for closure of the San Transfer Station has been prepared consistent with Title 30 Texas Administrative Code (TAC) §330.63(j). Cost estimates for closure are required for any municipal solid waste facility permitted or registered by the TCEQ. In the event of forced closure, which occurs when a solid waste facility can no longer operate because of an inability to manage the incurred debts and liabilities of closure, operations will be assumed by the TCEQ. This cost estimate for closure has been prepared for the San Antonio TS and is consistent with Title 30 TAC §330.505.

2 CLOSURE COST ESTIMATE

At any point in its active life, the maximum amount of waste that may be temporarily stored onsite at the facility and any processed and unprocessed waste and materials onsite is 2,500 tons. A detailed estimate, in current dollars, of the cost of hiring a third party that is not affiliated with the owner or operator to close the facility at any time during the active life, when the extent and manner of the facility's operations would make closure most expensive, is provided. The cleanup and disposition costs for onsite waste material are based on a weight measurement as shown in Table 2-1. No dismantling of the concrete pad or other structures will be conducted at closure. No changes to the site elevations at closure will occur that will affect the final contour map.

The estimated closure cost based on the above considerations is \$208,150 in 2023 dollars. A copy of the required documentation to demonstrate financial assurance shall be submitted 60 days prior to the initial receipt of waste.

Table 2-1
San Antonio Transfer Station
Cost Estimate for Third Party Closure

Item	Description	Cost
A	State Administration of third party site closure	
1	Site survey and file review to determine closure activities	\$1,500
2	Preparation of engineering plans	\$1,500
3	Procurement of bids	\$1,500
4	Contract award and administration of contract	\$1,000
5	Installation of sign stating facility closure	\$500
6	Buildings and site secured (locks and/or fencing, etc.)	\$500
B	Contractor mobilization	\$500
C	Sampling/testing/classification of waste (ash, liquids, sludge, other waste not readily identifiable as garbage, trash, refuse), to include lab reports, chain of custody, quality assurance and quality control.	\$2,000
D	Disposal of waste (2,500 tons @ \$65/ton) (approximate maximum storage capacity)*	
1	Cleanup/Removal of waste stored on site (2,500 tons @ \$10.00/ton)	\$25,000
2	Transport of waste by a properly authorized transporter (2,500 tons @ \$10.00/ton)	\$25,000
3	Treatment and/or disposal of waste at a properly authorized facility (2,500 tons @ \$45.00/ton)	\$112,500
E	General cleanup to include washdown and disinfection of facility (floors, walls, containment areas, processing areas) and removal, transport, treatment, and disposal of all wash down waters/media.	\$1,500
F	Removal, treatment, and disposal of any contaminated soils, concrete, stormwater, or other contaminated materials on site.	\$1,000
G	Cleanup and decommission (equipment should be rendered unusable) of process equipment/facility	\$1,500
H	Vector control	\$500
I	Inspection and certification of closure	\$5,000
	Closure Subtotal	\$181,000
	Contingency cost (15%)	\$27,150
	Total	\$208,150

* As noted in the Site Operating Plan, Section 8.10, the expected waste storage capacity is 2,500 tons for this facility.

3 COST ESTIMATE ADJUSTMENTS

During the active life of the facility, Lealco will establish and maintain financial assurance for closure in accordance with Title 30 TAC Chapter 37, Subchapter R.

An increase in the closure cost estimate and the amount of financial assurance provided must be made if changes to the facility conditions increase the maximum cost of closure. Under that scenario, request for an increase in the closure cost estimate and financial assurance will be submitted as a permit modification. The closure cost estimate will be evaluated annually to determine if an increase in the closure cost estimate is required based on the annual inflation adjustment factor.

A reduction in the closure cost estimate and the amount of financial assurance may be approved if the cost estimate exceeds the maximum cost of closure and the owner/operator has provided written notice to the Executive Director of the detailed justification for the reduction. A request for reduction in the closure cost estimate and financial assurance will be submitted as a permit modification request.

Continuous financial assurance coverage for closure must be provided until all requirements of the Closure Plan are completed and the facility is determined to be closed in writing by the Executive Director.

**SAN ANTONIO TRANSFER STATION
BEXAR COUNTY, TEXAS
TCEQ PERMIT NO. MSW-2420
TYPE V PERMIT APPLICATION**

**PART IV
SITE OPERATING PLAN**

Prepared for

Waste Connections Lone Star, Inc.

January 2024

Revised May 2024

Revised July 2024

Revised September 2024



Prepared by

Weaver Consultants Group, LLC

TBPE Registration No. F-3727

6420 Southwest Boulevard, Suite 206

Fort Worth, Texas 76109

817-735-9770

WCG Project No. 0601-012-11-01

This document is issued for permitting purposes only.

Tech. Complete App. - 439

CONTENTS

TABLES AND FIGURES		IV-iv
1	INTRODUCTION	IV-1
2	PERSONNEL AND TRAINING	IV-2
2.1	Personnel	IV-2
2.1.1	San Antonio TS Management Team	IV-2
2.1.2	Transfer Station Manager	IV-2
2.1.3	Scale House Attendant	IV-3
2.1.4	Equipment Operators	IV-3
2.1.5	Laborers	IV-4
2.1.6	Mechanics	IV-4
2.1.7	Other Site Personnel	IV-4
2.1.8	Other Corporate Resources	IV-4
2.2	Training	IV-4
2.3	Equipment	IV-5
3	WASTE ACCEPTANCE AND ANALYSIS (30 TAC §330.203 AND §330.205)	IV-7
3.1	Properties and Characteristics of Waste (§330.203(a))	IV-7
3.2	Volume and Rate of Transfer (§330.203(b) and §330.205(a) and (b))	IV-8
3.3	Waste Sampling and Analysis for Processing and Experimental Facilities (§330.203(c))	IV-9
4	CONTAMINATED WATER MANAGEMENT (30 TAC §330.207)	IV-10
5	STORAGE REQUIREMENTS (30 TAC §330.209 AND §330.213)	IV-11
5.1	Solid Waste Storage (§330.209(a))	IV-11
5.2	Approved Containers (§330.211)	IV-11
6	RECORDKEEPING AND REPORTING REQUIREMENTS (30 TAC §330.219)	IV-12
6.1	Documents (§330.219(a))	IV-12
6.2	Records to be Maintained (§330.219(b))	IV-12
6.3	Report Signatories (§330.219(c))	IV-12
6.4	Notification (§330.219(e))	IV-13
6.5	Record Retention (§330.219(f))	IV-13
6.6	Alternative Schedules (§330.219(g))	IV-13

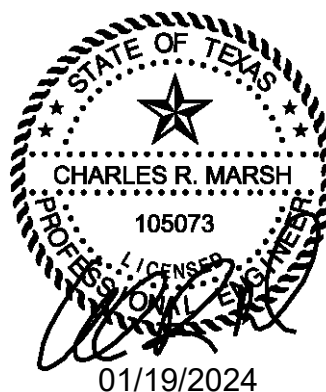

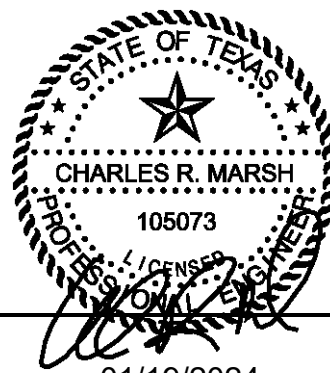

CONTENTS (Continued)

	6.7 Personnel Training Records and Licenses	01/19/2024	IV-13
	6.8 Annual Waste Acceptance Rate Documentation and Recording (§330.675)		IV-13
7	FIRE PROTECTION PLAN (30 TAC §330.221)		IV-16
	7.1 Fire Prevention Procedures		IV-16
	7.2 General Rules for Fires		IV-17
	7.3 Specific Fire-Fighting Procedures		IV-17
	7.4 Fire Protection Training		IV-18
8	OPERATIONAL PROCEDURES (30 TAC §330.223 THROUGH §330.249)		IV-19
	8.1 Access Control (§330.223)		IV-19
	8.1.1 Facility Security		IV-19
	8.1.2 Traffic Control		IV-19
	8.1.3 On-site Access Roads and Parking		IV-20
	8.2 Unloading of Waste (§330.225)		IV-20
	8.2.1 Waste Unloading Procedures		IV-20
	8.2.2 Procedures for the Detection and Prevention of Unauthorized Waste		IV-21
	8.3 Spill Prevention and Control (§330.227)		IV-22
	8.4 Operating Hours (§330.229)		IV-22
	8.5 Facility Sign (§330.231)		IV-23
	8.6 Control of Windblown Material and Litter (§330.233)		IV-24
	8.7 Materials Along the Route to the Facility (§330.235)		IV-24
	8.8 Facility Access Roads (§330.223(b) and §330.237)		IV-24
	8.9 Noise Pollution and Visual Screening (§330.239)		IV-25
	8.10 Overloading and Breakdown (§330.241)		IV-25
	8.11 Sanitation (§330.243)		IV-26
	8.12 Ventilation and Air Pollution Control (§330.245)		IV-26
	8.13 Health and Safety (§330.247)		IV-26
	8.14 Employee Sanitation Facilities (§330.249)		IV-26
	8.15 Facility Inspection and Maintenance Schedule		IV-27
9	GENERAL INSTRUCTIONS		IV-28
	9.1 General Facility Safety		IV-28

TABLES AND FIGURES

Tables		Page
3-1	Expected Waste Stream Percentages	IV-8
6-1	Records to be Maintained in the Site Operating Record	IV-17
8-1	Facility Inspection and Maintenance Schedule	IV-29
Figures		
2.1	Organizational Chart	IV-6



1 INTRODUCTION

This Site Operating Plan (SOP) has been prepared for the San Antonio Transfer Station (TS), a Type V MSW processing facility, and contains the information required by Title 30 Texas Administrative Code (TAC) §330.65 and Title 30 TAC §330, Subchapter E. This SOP includes provisions for facility management and facility operating personnel to meet the general and facility-specific requirements included in Subchapter E: Operational Standards for Municipal Solid Waste Storage and Processing Units for the day-to-day operation of the facility. This SOP will be retained onsite throughout the active life of the facility until after certification of closure.

This section addresses §330.65 and §330.201. Additional specific regulatory citations are indicated within the Part IV section headings.

The San Antonio TS is located in Bexar County, Texas and is accessed from FM 1346 Road. The site is located at 10244 Farm to Market 1346, Bexar County, Texas, 78101. The San Antonio TS will accept waste from public and private waste hauling vehicles and directly from the public. Waste material will be transferred to a permitted municipal solid waste (MSW) landfill. Support facilities include a site entrance road, scale house, and break room.

This SOP provides guidance for facility management and operating personnel for daily operation of the San Antonio TS. This SOP also includes provisions for facility management and operating personnel to meet the general and facility-specific requirements.

2 PERSONNEL AND TRAINING

2.1 Personnel

This section lists the personnel involved with the operation of the San Antonio TS. The San Antonio TS Management Team and Site Personnel are listed on the organizational chart shown on Figure 2.1. The following subsections describe the personnel involved with operating the San Antonio TS.

2.1.1 San Antonio TS Management Team

The Division Vice President has management and oversight responsibilities for all operations within the geographic region. The District Manager is responsible for all hauling, recycling, and transfer operations in the area. The District Manager's responsibilities include staff management, financial planning, as well as other management responsibilities. The District Manager reports to the Division Vice President. The District Manager is responsible for operations oversight at transfer stations and recycling facilities in the area, including the San Antonio TS. The Transfer Station Manager reports to the District Manager. Other corporate resources that are available to the San Antonio TS management team are discussed in Section 2.1.8.

2.1.2 Transfer Station Manager

The Transfer Station Manager is responsible for daily operations, administers the facility's SDP and SOP, and will also serve as the emergency coordinator. This person is responsible for assuring that adequate personnel and equipment are available to provide facility operation in accordance with this SOP, the SDP, TCEQ regulations, and other applicable local, state or federal regulations. The Transfer Station Manager will maintain an adequate level of competency, training and experience to fulfill these duties. The Transfer Station Manager will designate an individual(s) to fulfill his or her duties during periods when the Transfer Station Manager is absent. These individuals will be one of the personnel listed in this section and may have similar training and certification as the Transfer Station Manager. Wherever this SOP provides that responsibility or authority is assigned to the Transfer Station Manager, this responsibility or authority may be routinely delegated to the individual(s) so designated by the Transfer Station Manager for this duty. All onsite employees, which may include Scale House Attendant, Equipment Operators, Mechanics, and Laborers, are under the supervision of the Transfer Station Manager or his designee. The Transfer Station Manager is responsible for hiring and terminating personnel in these positions.

The Transfer Station Manager must hold an MSW Supervisor Occupational License of Class B or above. The Transfer Station Manager must be familiar with the specific operating procedures set forth in this plan and will participate in training with other employees. The Transfer Station Manager, or his designee, is also responsible for routine site inspections as described herein, as well as any other requirements set forth in this SOP that are not specifically designated to certain personnel.

2.1.3 Scale House Attendant

The primary job of the Scale House Attendant, stationed near the site entrance, is to maintain complete and accurate records of vehicles and solid waste entering the facility. The Scale House Attendant will be familiar with site safety procedures, to visually check for unauthorized wastes, to weigh vehicles, collect waste disposal fees, and direct vehicles to the appropriate unloading area. The Scale House Attendant reports to the Transfer Station Manager. Specifically, the Scale House Attendant is required to: (1) monitor the incoming vehicles for type of waste and exclude prohibited waste; (2) inspect waste loads to confirm that they are authorized for disposal; (3) review manifests and other shipping documents; (4) record incoming waste loads; (5) review and confirm special waste documents; and (6) accept tipping fees. The Scale House Attendant will direct visitors to their destination within the facility.

Any questions regarding acceptance of waste are to be addressed to the Transfer Station Manager and may include coordination with Corporate/Company Engineering and Compliance Managers.

The minimum qualifications for the Scale House Attendant are being able to fulfill the duties described in this section.

2.1.4 Equipment Operators

The Equipment Operators report to the Transfer Station Manager. Equipment Operators are responsible for the safe operation of the equipment. As the personnel most closely involved with the actual site operation, these employees are responsible for being alert for potentially dangerous conditions, or careless and improper actions on the part of nonemployees and other persons while on the premises. Equipment Operators monitor and direct unloading vehicles and can also be responsible for maintenance, construction, litter abatement, and general site cleanup. Equipment Operators are also responsible for identifying prohibited wastes. The Equipment Operators will intervene as necessary to prevent accidents. Equipment Operators will also report any operational problems to the Transfer Station Manager. The minimum qualifications for the Equipment Operators are being able to fulfill the duties described in this section. Equipment Operators that are hired on the basis of specific heavy equipment experience may be assigned to operate specific types of equipment without additional training.

All Equipment Operators are required to wear personal safety equipment, as appropriate, for their work assignments.

2.1.5 Laborers

Laborers will provide miscellaneous operations support at the facility. This support will include but is not limited to: check for unauthorized materials, sweep the operation area, perform facility wash-down, collection and disposing of windblown litter, general equipment and building maintenance, and directing and spotting vehicles in the unloading areas.

2.1.6 Mechanics

Mechanics perform necessary and routine maintenance on equipment. Mechanics may substitute as Equipment Operators. Mechanics report to the Transfer Station Manager. The minimum qualifications for the Mechanics are being able to fulfill the duties described in this section. The site may also use third party mechanics to perform maintenance on the equipment.

2.1.7 Other Site Personnel

Other Site Personnel may be employed from time to time in categories such as maintenance, construction, litter abatement, and general site cleanup. Other Site Personnel report to the Transfer Station Manager or his designee. Also, additional personnel will be utilized in the event of a temporary waste inflow increase due to a large special event project.

2.1.8 Other Corporate Resources

Waste Connections Lone Star, Inc. (WCLSI) possesses additional solid waste management and operational resources, including consulting and management resources, which are available to site personnel, as needed. The Transfer Station Manager can contact appropriate personnel to provide additional assistance at any time.

Engineering and Compliance Managers will provide review and approval of pre-authorized requests for certain wastes received at the site. They may also provide pre-authorization approval for wastes and will provide oversight for waste acceptance by the Scale House Attendant and assist with other site regulatory matters, as requested by the Transfer Station Manager.

2.2 Training

Transfer station personnel will be properly trained in the operations of the facility as described in this SOP, operational standards required by the permit, and the relevant TCEQ municipal solid waste regulations. Job-specific training may include SOP requirements, regulatory compliance, and compliance with other plans such as the Spill Prevention Control and Countermeasure Plan (SPCC) (if required), the Storm Water Pollution Prevention Plan (SWP3) (if required), the content and use of the fire protection plan, the Special Waste Acceptance Plan, and general safety procedures.

A description of training provided to each employee will be maintained in the site operating record.

2.3 Equipment

The facility will typically use one bucket front-end loader and one raised-cab basket grapple loader with a scale (or similar materials handling equipment) for the transfer operations. The minimum equipment required to operate the facility is one front-end loader. Collection vehicles will unload MSW within the TS on the tipping floor. A front-end loader will typically push the MSW towards a grapple loader (or similar materials handling equipment), which will transfer the MSW from the tipping floor into the transfer trailers located in the tunnel. Grapples may also be used to compact waste or more evenly distribute the waste within the transfer trailer. The facility will have an initial rate of waste acceptance of 2,500 TPD. WCLSI will provide sufficient equipment if the volume of daily waste transfer will require additional equipment.

Additional company-owned or rental equipment, such as road tractors, water trucks, and backhoes, may be provided as necessary to enhance operational efficiency. At infrequent times, such as during equipment breakdown or periodic maintenance, additional equipment stationed at other company facilities will be transported to the transfer station as needed. Other equivalent types of equipment may be substituted on an as-needed basis to adequately maintain the transfer station and meet the operational standards required by the TCEQ's regulations in accordance with all applicable local, state, and federal regulations.

Equipment used for waste staging and loading (front-end loaders and grapple loaders) will be maintained in an operational state, and periodically will be cleaned (e.g., sweeping, washing, etc.) on an as-needed basis to prevent the accumulation of waste residue on the equipment and the creation of odors.

**Figure 2.1
San Antonio Transfer Station
Organization Chart**

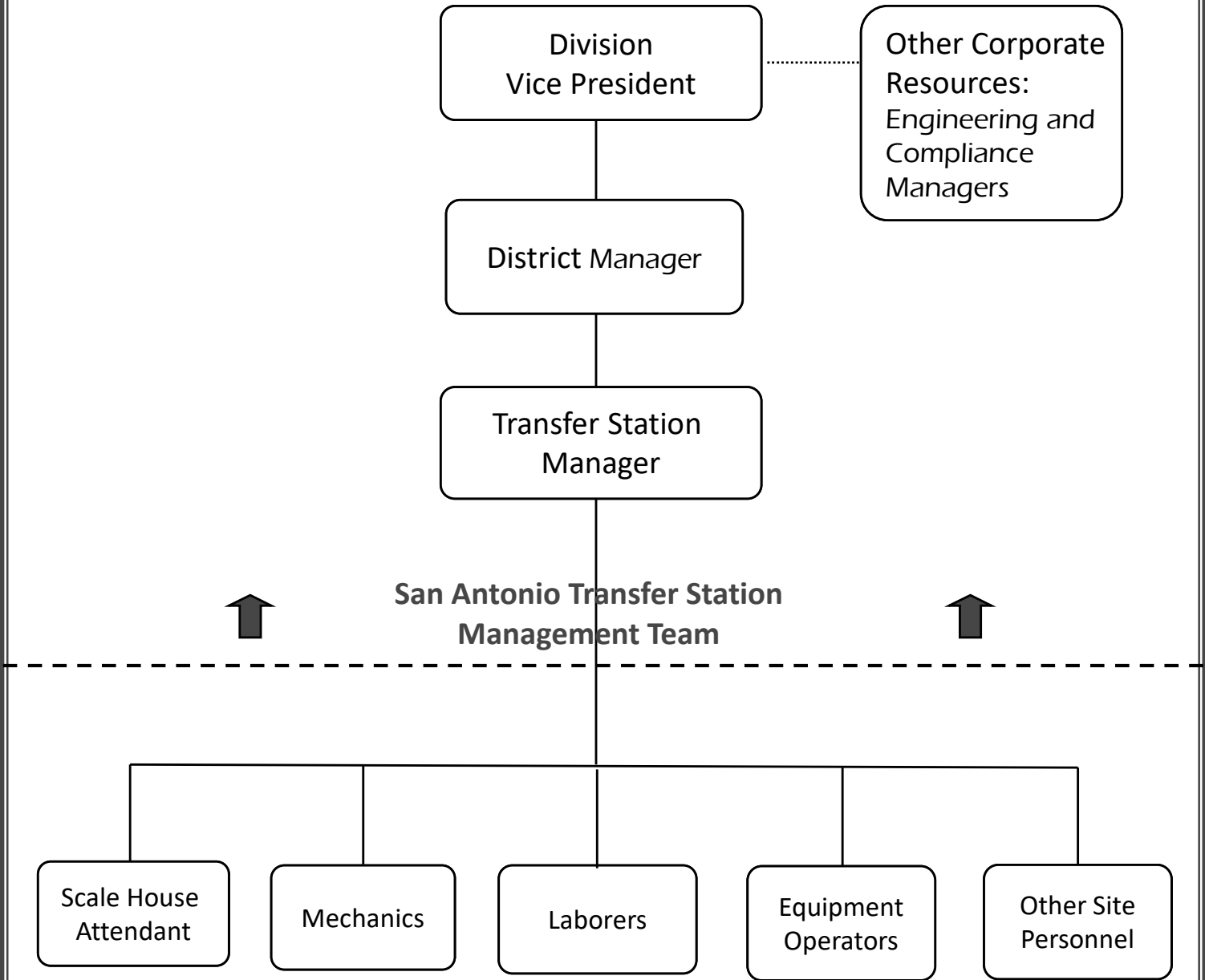

3 WASTE ACCEPTANCE AND ANALYSIS (30 TAC §330.203 AND §330.205)

3.1 Properties and Characteristics of Waste (§330.203(a))

The major classifications of solid waste accepted at the San Antonio TS for transfer to a properly permitted municipal solid waste facility include household waste; yard waste; commercial waste; Class 2 and Class 3 non-hazardous industrial waste; and construction-demolition waste. The waste classifications are defined in Title 30 TAC §330.3. Special wastes may also be accepted at the facility. Appendix IVA – Special Waste Acceptance Plan details the special waste acceptance and handling procedures.

The San Antonio TS accepts waste generated from residential, commercial, institutional, municipal, manufacturing, industrial, recreational, and construction sources within the City of San Antonio, Bexar County, and the surrounding areas. It is anticipated wastes accepted will include paper, food wastes, glass, aluminum, metals, plastics, grass clippings, other organic wastes, wood wastes, textiles, bricks, and other inert materials.

Consistent with Title 30 TAC §330.15 (relative to general prohibitions), the facility will not accept Class 1 non-hazardous industrial wastes, regulated hazardous wastes, regulated asbestos-containing material (RACM), liquid wastes, radioactive wastes, PCB wastes, untreated medical wastes, or other wastes prohibited by TCEQ regulations. Class 1 waste is further defined in 30 TAC §335.505. Class 2 industrial solid waste is any individual solid waste or combination of industrial solid wastes that cannot be described as Class 1 or Class 3, as defined in Title 30 TAC §335.506 (relating to Class 2 waste determination). Examples of Class 2 industrial waste include “plant trash” or waste originating in the facility offices or plant production areas that are composed of paper and/or wooden packaging materials, glass, aluminum foil, aluminum cans, aluminum scrap, stainless steel, steel, iron scrap, Styrofoam, rope, twine, uncontaminated rubber, uncontaminated wooden materials, equipment belts, wiring, uncontaminated cloth, metal buildings, empty containers with a holding capacity of five gallons or less, uncontaminated floor sweepings, or food packaging that are produced as a result of plant production. Class 3 industrial solid waste is any inert and essentially insoluble industrial solid waste, including materials such as rock, brick, glass, dirt, and certain plastics and rubber, etc., that are not readily decomposable as defined in Title 30 TAC §335.507 (relating to Class 3 waste determination). Class 2 and Class 3 industrial solid wastes may be accepted at the facility provided processing of these wastes does not interfere with proper operation of the facility.

Bulky and large items arriving at the TS will be placed on the tipping floor so as to allow the wheel loader to crush and flatten the items prior to loading into the transfer trailer. Where this is not possible, bulky or large items will be loaded into transfer trailers that have been partially filled to prevent damage to the trailer from impact due to the heavy weight of the bulky and large items. Appliances potentially containing refrigerant will be inspected to ensure that any refrigerant has been extracted in accordance with Section 608 of the Federal Clean Air Act. Items containing chlorinated fluorocarbons (CFCs) will be handled in accordance with 40 CFR Part 82.

3.2 Volume and Rate of Transfer (§330.203(b) and §330.205(a) and (b))

The San Antonio TS serves individuals and public and private collection vehicles from the City of San Antonio, Bexar County, and surrounding areas. The TS will be developed to process and transfer solid waste up to the initial daily waste acceptance rate of 2,500 tons/day. The TS is designed for efficient waste processing. The area to be used for waste transfer operations will be 150 feet by 130 feet. Facility layout drawings are included in Part III, Appendix IIIA.

The following types and estimated percentages of waste stream are expected to be received at the TS. The waste types and percentages are estimates only and may vary based upon the actual wastes received at the TS.

**Table 3-1
Expected Waste Stream Percentages**

Type of Waste	Expected Percentage of Waste Stream
Residential Waste	50%
Commercial/Institutional Waste	20%
Construction and Demolition Waste	10%
Class 2 and 3 Industrial Waste	5%
Special Waste	5%
Other Authorized Waste	5%
Source- Separated Recyclables	5%

Material will be transferred to a permitted municipal solid waste facility typically on a daily basis or to a third-party recycler as needed. As economic conditions, population growth, and waste generation rates change, the volume of incoming waste may vary. As noted in Section 6.8, the waste acceptance rate for the facility will be reported annually.

The facility is designed to transfer waste materials received so they can be efficiently transported to a landfill. The maximum amount of waste that may be stored overnight at the facility is 2,500 tons. MSW accepted at the TS will be transferred on a daily basis, and the maximum length of time material will remain onsite is 48 hours, except holidays as discussed in Section 8.10; and during holidays, waste may be temporarily stored at the facility not to exceed a time period of 72 hours. Waste will not be stored on the transfer station floor at night or on the facility premises after closing hours on Saturdays and Sundays. The tipping floor will receive at least a weekly one-hour pressure wash at a flow rate of approximately 5 GPM. Therefore, the anticipated wash down water generation is 300-350 gallons per week. Contaminated water generated from washing the tipping floor will be stored in a minimum 2,000-gallon holding tank and transported to a permitted treatment facility for disposal. Alternatively, an aboveground storage tank and sump may be used for the wash-down water. The San Antonio TS will not discharge contaminated water without a separate, specific written authorization from TCEQ. The San Antonio TS will maintain documentation at the facility that all wastes leaving the facility are being adequately managed by other licensed or permitted facilities.

3.3 Waste Sampling and Analysis for Processing and Experimental Facilities (§330.203(c))

This regulation is not applicable to this facility. This facility only transfers waste; there is no on-site processing of grit trap wastes, sludges, or effluent from a treatment process. Management of contaminated water generated at the facility is discussed in Section 4.0.

4 CONTAMINATED WATER MANAGEMENT (30 TAC §330.207)

The San Antonio TS will take the steps necessary to control and prevent the discharge of contaminated water from the facility. As noted in Section 2.3.1 of the SDP, the San Antonio TS is designed to manage stormwater in a controlled manner that will not cause surface water or groundwater pollution. Contaminated water generated by the facility will consist of 300-350 gallons of water per week resulting from wash water applied to the tipping floor. Contaminated water will be directed to a minimum 2,000 gallon holding tank. The facility's total wastewater storage capacity is at least 2,500 gallons, sufficient for approximately seven weeks of wastewater storage. The holding tank will be pumped, as necessary, and the water will be hauled to a permitted treatment facility for disposal. The owner/operator will not discharge contaminated water without a separate, specific written authorization from TCEQ.

Discharge of water from the transfer station tipping floor area will not occur. All water coming in contact with waste will be treated as contaminated water. The TS will be operated consistent with Title 30 TAC §330.15(h)(1)-(4), regarding prohibiting the unauthorized discharge of solid wastes or pollutants into waters of the United States. Contaminated water discharged (by tanker or to a future sanitary sewer service connection) to a permitted treatment facility will conform to the testing requirements of the receiving facility.

Uncontaminated stormwater run-on and runoff will be directed away from the TS structure entrances by site grading. Stormwater will be managed by maintaining the existing surface water patterns in areas outside of the TS structure footprint.

5 STORAGE REQUIREMENTS (30 TAC §330.209 AND §330.213)

5.1 Solid Waste Storage (§330.209(a))

Solid waste entering the facility will be stored in the covered TS structure or loaded in transfer trailers. All solid waste will be stored in a manner to prevent fires, ensure safety, prevent and control vectors and odors, and contained to prevent windblown solid waste and litter. In the event additional measures are deemed necessary for vector or pest control, methods of control might include spraying, baits, traps, or other measures suitable for the identified pest or vector.

No solid waste loading, storage, or disposal will occur within any easement, buffer zone, or right-of-way that crosses the facility. When necessary, MSW material will be stored onsite for a maximum time not to exceed 48 hours, except on holidays, where it will not exceed 72 hours. Waste will not be stored on the transfer station floor at night or on the facility premises after closing hours on Saturdays and Sundays. The volume of MSW stored overnight will not exceed 2,500 tons; and waste that is stored overnight will be in tarped transfer trailers or will be covered with a tarp on the TS tipping floor. Tarping of segregated recyclable materials will not be required.

5.2 Approved Containers (§330.211)

Citizen vehicles entering the TS facility may deposit waste onto the TS tipping floor. Solid waste from waste hauling vehicles and filled roll-off containers from the citizens convenience drop-off area may be discharged onto the TS tipping floor. Waste placed on the TS tipping floor will be transferred to transfer trailers. The transfer trailers used by the TS are durable and designed for safe handling and easy cleaning. The transfer trailers are equipped with tarps or covers to be used during transport. In addition, the trailers are designed to prevent spillage or leakage during storage, handling, or transport.

Non-reusable containers will be of suitable strength to minimize scavenging or rupturing. If used, any container emptied manually will be capable of being serviced without the collector coming into contact with waste.

6 RECORDKEEPING AND REPORTING REQUIREMENTS (30 TAC §330.219)

6.1 Documents (§330.219(a))

The San Antonio TS will maintain the operating record for the facility on site. Consistent with Title 30 TAC §330.219(a), copies of documents that are part of the approved permitting process that are considered part of the operating record for the facility are listed in Table 6-1. As noted in Table 6-1, trip tickets will be retained for 5 years.

These documents will be made available for inspection by TCEQ representatives or other interested parties.

6.2 Records to be Maintained (§330.219(b))

The San Antonio TS in accordance with Title 30 TAC §330.219(b), will promptly record and retain in the operating record any and all records for those items listed in Table 6-1.

6.3 Report Signatories (§330.219(c))

San Antonio TS personnel will sign all reports and other information requested by the Executive Director as described in Title 30 TAC §305.44(a) or by an authorized representative of the San Antonio TS. For a person to be an authorized representative of the San Antonio TS the authorization must: (1) be made in writing as described in Title 30 TAC §305.44(a), (2) specify either an individual or a position having responsibility for the overall operation of the San Antonio TS, and (3) submitted in writing to the Executive Director.

If an authorization is no longer accurate because of a change in individuals or position, a new authorization will be submitted to the Executive Director prior to or with any submittal to be signed by an authorized representative. Any person signing such a report will make the certification included in Title 30 TAC §305.44(b).

6.4 Notification (§330.219(e))

The San Antonio TS, in accordance with Title 30 TAC §330.219(e), will furnish the operating record to the Executive Director upon request and will be made available at all reasonable times at the facility for inspection by the Executive Director.

6.5 Record Retention (§330.219(f))

In accordance with Title 30 TAC §330.219(f), the site will retain all information contained within the operating record of the facility, and all plans required for the facility for the life of the facility until after certification of closure.

6.6 Alternative Schedules (§330.219(g))

The Executive Director, in accordance with Title 30 TAC §330.219(g), may set alternative schedules for recordkeeping and notification requirements as specified in Title 30 TAC §330.219(a) – (e).

6.7 Personnel Training Records and Licenses

The San Antonio TS will maintain personnel training records. Personnel training requirements will be consistent with Section 2 – Personnel and Training. Personnel training records for current facility personnel will be maintained until closure of the facility. The facility will maintain operator licenses for municipal solid waste supervisors as required by 30 TAC Chapter 30, Subchapter F. Personnel training records and personnel operator licenses will be maintained in the operating record as listed in Table 6-1.

Copies of special waste manifests and approval forms utilized by the landfill for waste acceptance will be maintained on site for at least three years. Other documents, such as agency correspondence and waste acceptance records (e.g., manifests, trip tickets, and other waste acceptance records), older than three years may be maintained at (1) the site or (2) an off-site storage facility which either owned by the permit holder or one that is under contract with the site to manage these records.

6.8 Annual Waste Acceptance Rate Documentation and Recording (§330.675)

As listed in Table 6-1, the facility will maintain records to document the annual waste acceptance rate for the facility. Documentation will include maintaining the quarterly

solid waste summary reports and the annual solid waste summary reports required by Title 30 TAC §330.675 in the site operating record.

**Table 6-1
Records to be Maintained in the Site Operating Record**

Records to be Maintained in the Site Operating Record	Frequency	Rule Citation
MSW Permit	Once	§330.219(a)
Approved Permit application	Updated as modifications are approved	§330.219(a)
Site Operating Plan	As updated	§330.219(a)
Other required plans or related documents	As updated	§330.219(a)
Location restriction demonstrations	As updated	§330.219(b)(1)
Inspection records (including drainage inspections and actions taken for drainage repairs) and training procedures	Per occurrence	§330.219(b)(2)
Closure plans and any monitoring, testing, or analytical data relating to closure requirements	As required	§330.219(b)(3)
Cost estimates and financial assurance documentation relating to closure	Annually	§330.219(b)(4)
Correspondence and responses relating to facility operation, permit modifications, approvals, and technical assistance	Per occurrence	§330.219(b)(5)
All documents, manifests, shipping documents, trip tickets, etc., involving special waste	Per occurrence	§330.219(b)(6)
Other documents specified in the permit or by the Executive Director	As required	§330.219(b)(7)
Trip tickets as required by §312.145(b)(2)	Per occurrence (retained for 5 years)	§330.219(b)(8)
Scale tickets and database records demonstrating minimum 10% source separation and diversion recycling	Per occurrence	§330.9(g)(l)
Dates, times, and durations of alternative operating hours (e.g., if not as stated in Section 8.4)	As required	§330.219(g) and §330.229(d)
Inspection records and training procedures relating to fire prevention and facility safety	As needed	§330.221(c)
Personnel training records (including topics covered and attendee list) and detailed job descriptions	As needed	§330.219(b)(2)
Records to document the annual waste acceptance rate	Annually	§330.219(b)(9) and §330.675
Load inspection records	Per occurrence	§330.225
Personnel operator licenses	As needed	§330.219(b)(2)
All site inspection and maintenance documentation noted in Section 8.15 – Facility Inspection and Maintenance Schedule	As required	§§330.223 – 330.243
A record of each unauthorized material removal event	Per occurrence	§330.225
Documentation that all wastes leaving the facility are being adequately managed by other licensed or permitted facilities.	As needed	§330.205(a)
As-built set of construction plans	As needed	§330.219(a)
Log of abnormal events	Per occurrence	§330.219(d)(1)
Report and supporting records demonstrating that at least 10% of the volume of the waste received was processed to recover solid material that was recycled or reused.	Quarterly (sent to Executive Director and maintained in site operating record)	§330.9(f)(1)

7 FIRE PROTECTION PLAN (30 TAC §330.221)

7.1 Fire Prevention Procedures

The following steps will be taken regularly by designated site personnel to prevent fires.

- Burning waste from incoming waste loads will be prevented from being unloaded within a building. The Scale House Attendant will be alert for signs of burning waste such as smoke, steam, or heat being released from incoming waste loads. The vehicle will be directed to an area away from and not adjacent to the buildings, or within 40 feet of any building, where waste can be safely discharged and the fire extinguished. Upon extinguishing the fire, the waste will be immediately moved to the TS. Fire extinguisher water will be managed as contaminated water (refer to Section 4).
- Equipment used at the facility will be routinely cleaned through the use of water, steam cleaners, or compressed air. The water or steam cleaning will remove combustible waste and caked material which can cause equipment overheating and increase fire potential. Equipment wash water will be managed as contaminated water (refer to Section 4).
- Fuel spills will be contained and cleaned up immediately and will be properly managed as directed by the Transfer Station Manager.
- Smoking is not allowed in the working areas of the site. Smoking is confined to designated areas only, away from the active tipping floor and waste handling areas, and other fire-sensitive areas.
- The facility will be equipped with fire extinguishers. Each fire extinguisher will be fully-charged and ready for use at all times. Each extinguisher will be inspected on an annual basis and recharged as necessary. These inspections will be performed by a qualified service company, and all extinguishers will display a current inspection tag. Inspection and recharging will be performed following each use. At a minimum, each building and applicable equipment will have fire extinguishers.
- The facility will be equipped with fire extinguishers located throughout the facility. Bexar County Emergency Services District #10, Fire Station is located on FM 1346 approximately five miles west of the facility. Emergency response telephone numbers will be located throughout the facility.

7.2 General Rules for Fires

The following rules will be implemented in the event of a fire at the San Antonio TS.

- Contact the City of San Antonio Fire Department by calling 911.
- Immediately contact the Transfer Station Manager.
- Alert other facility personnel.
- Assess extent of fire, possibilities for the fire to spread, and alternatives for extinguishing the fire.
- If it appears that the fire can be safely fought with available fire fighting devices until arrival of the Fire Department, attempt to contain or extinguish the fire.
- Upon arrival of Fire Department personnel, direct them to the fire and provide assistance as appropriate.
- Do not attempt to fight the fire alone.
- Do not attempt to fight the fire without adequate personal protective equipment.
- Be familiar with the use and limitations of firefighting equipment available onsite.
- Firefighting methods include spraying the burning material with water from the hose. If detected soon enough, a small fire may be fought with a hand-held fire extinguisher.

7.3 Specific Fire-Fighting Procedures

The following procedures will be followed in the event of a fire.

- If a fire occurs on a vehicle or piece of equipment, the operators should bring the TS vehicle or TS equipment to a safe stop. If safety of personnel will allow, the vehicle must be parked away from fuel supplies, solid wastes, and other vehicles. The vehicle will be directed to park on a paved area at least 40 feet from any building. The engine should be shut off and the brake engaged to prevent movement of the vehicle. Fire extinguishers should be used to extinguish a fire if possible, without risk to operators.
- If a fire is on the tipping floor, the burning area should be isolated and pushed away from the other waste quickly. The burning area should be sprayed with water from the large wash down hoses or, if small enough, extinguished with a hand-held fire extinguisher.

- If burning waste materials are discovered after having been delivered to the site, the vehicle will be directed to an area away from buildings. Then the waste will be discharged and the fire extinguished. Upon extinguishing the fire, the waste will be immediately moved to the TS.
- The fire extinguisher(s) located within each building, located on the piece of equipment or vehicle, or hoses within the TS building may be used to extinguish a fire, as appropriate.
- The site water supply is provided by a TCEQ approved public water system that is capable of providing the facility with an around-the-clock supply of potable water with adequate pressure. A fire hydrant will be installed on the northwest corner of the transfer station, directly north of the wastewater storage tank. Maximum hose lay length from this hydrant will be 300 feet to all parts of the TS building providing sufficient fire protection.

7.4 Fire Protection Training

Site personnel will be trained in the contents of Section 7 – Fire Protection Plan. Training will be conducted annually. The following topics will be addressed.

- Fire Prevention
- Fire Safety
- Fire Fighting Procedures
- Fire Extinguisher Use and Capabilities

8 OPERATIONAL PROCEDURES (30 TAC §330.223 THROUGH §330.249)

8.1 Access Control (§330.223)

Public access to the facility will be limited to the gated facility entrance. The Scale House Attendant controls access and monitors vehicles entering and exiting the site. The site will be fenced with a four-foot barbed wire fence or a six-foot chain-link fence, or other suitable fencing to prevent unauthorized public access.

8.1.1 Facility Security

Facility security measures are designed to prevent unauthorized persons from entering the facility, to protect the site and its equipment from possible damage caused by trespassers, and to prevent disruption of facility operations caused by unauthorized facility entry.

Unauthorized entry into the facility will be minimized by controlling access to the site with fencing (see Section 8.1). Gates constructed of suitable fencing materials will be located on the entrance road. The gates will be locked when the facility is not accepting waste and the offices are closed.

Entrance to the facility will be monitored by the scale house personnel during facility operating hours. Outside waste acceptance hours, gates will be locked. A sign regulating access at the FM 1346 entrance will be posted to restrict access during non-operating hours to company personnel only.

Entry to the facility will be restricted to designated personnel, appropriate subcontractors, approved waste haulers, the public, TCEQ personnel, and properly identified persons whose entry is authorized by facility management. Visitors may be allowed on the site only when accompanied by a facility representative.

8.1.2 Traffic Control

Access to the facility is via an existing driveway and through the gates on the northeast side of the facility. The Scale House Attendant will restrict facility access to authorized vehicles and direct these vehicles appropriately.

The facility may use a combination of signs, pavement markings, and directions provided by site personnel to direct customers to the correct unloading location and

to exit the facility. Vehicles will deposit their loads within the TS building and depart the site.

Roads not being used for access will be blocked or otherwise marked for no entry. An adequate turning radius for the vehicles utilizing the facility will be provided to maintain normal traffic flow.

Refer to Section 8.8 for access road dust and mud control requirements.

8.1.3 On-site Access Roads and Parking

On-site access roads will have a minimum of two-lane widths, all-weather surface (e.g., aggregate, asphalt, concrete), a gravel shoulder, and a bypass lane (at the scales).

Parking for vehicles is provided immediately south of the scale house for scale house staff and visitors. Transport equipment and employee parking will be available on the southern side of the office building.

Equipment parking and staging will be directed by transfer station personnel so as not to block or hinder ingress or egress to the transfer station tipping floor by waste transport vehicles or transport trailers. Equipment and employee parking will be designated based on observed waste hauler traffic patterns and will provide a safe place for parking by employees. Potential parking areas are shown on Figures I/II-4.4 and IIIA-2.

8.2 Unloading of Waste (§330.225)

8.2.1 Waste Unloading Procedures

Incoming waste collection traffic will be directed to the tipping area, or unloading area, of the TS by the Scale House Attendant once the vehicle incoming weight or volume has been recorded. The Scale House Attendant will inform the customer that the waste is only to be unloaded in the area where the customer is directed by site operating personnel to unload. Signs directing traffic from the Scale House to the TS structure will be located, as needed, along the route to the unloading areas. The unloading of waste will be directed by personnel working inside the TS. Equipment operators and other personnel will be on duty during operating hours to direct traffic to the unloading areas. Waste loading and unloading operations will only occur within the transfer station building.

The operator will use the front-end loader as needed to push the waste to the push wall or into the transfer trailers. Waste transfer operations will be confined within the TS structure and will not be exposed outside the building. If additional loading positions are added to increase the storage capacity of the transfer station, additional equipment may be used to transfer waste to the transfer trailers.

Waste will not be unloaded within any easements, zones, or rights-of-way. Unloading of waste in unauthorized areas will be prohibited. Any waste which is identified as having been deposited in an unauthorized area will be immediately moved to the unloading areas.

Prohibited waste will not be allowed to enter the facility. The Scale House Attendant is the first point of contact with the hauler. The hauler will be asked to inform the Scale House Attendant of the content of the load. The Scale House Attendant visually inspects containers to verify contents. In the event prohibited wastes are identified in the load, the entire load is turned away from the gate and not allowed entrance to the site. In addition, if the waste haul vehicle is delivering special or industrial waste, site personnel will visually compare the material presented for disposal to the Special Waste Profile (SWP) or similar form to confirm that the physical characteristics (i.e., color, odor, and appearance) of the material match those detailed on the SWP. In the event that the physical characteristics of the waste differ from the approved waste stream, the waste load will be rejected (refer to Section 2 of Appendix IVA). Class 1 nonhazardous solid waste (including RRC waste above 1,500 mg/kg TPH) will not be accepted at the transfer station.

In the event unauthorized waste is not discovered until after the collection vehicle that delivered it is gone, the site will attempt to segregate the unauthorized waste and manage it properly as directed by the Transfer Station Manager. The site will, if necessary, notify the TCEQ and seek guidance on how to dispose of the waste. Documentation will be included in the site operating record each time unauthorized or prohibited waste is discovered and removed from the site. Site personnel will have a basic understanding of both industrial and hazardous waste and their transportation and disposal requirements.

8.2.2 Procedures for the Detection and Prevention of Unauthorized Waste

Procedures for the detection and prevention of the disposal of unauthorized waste, including regulated hazardous waste as defined in 40 CFR Part 261 and polychlorinated biphenyl (PCB) wastes as defined in 40 CFR Part 761, are provided in this section.

Random visual inspections of incoming waste will be conducted. Although the inspection location may vary, all inspections will be made in areas where containment is provided and/or potential spills of unauthorized waste would be minimized. Vehicles that transport commercial and industrial waste will be considered for inspections. Such vehicles typically include front-end loaders, commercial rear-end loaders, side loaders, trucks with roll-off boxes, stake-bed trucks, dump trucks, pick-up trucks, and pick-up trucks with trailers transporting non-household wastes.

Vehicles containing suspicious loads will be inspected. Suspicious loads may include:

- Drums or containers with warning labels
- Loads which have a visible emission, smoke, strong chemical odor, or cause physical symptoms (e.g., irritation of eyes, nose, throat, skin, nausea, dizziness, or headache).

The inspector will not physically inspect any vehicle that appears to present possible physical danger. The Transfer Station Manager or his designee will be contacted immediately if such a load enters the facility.

The Transfer Station Manager or his designee will determine when to conduct inspections of incoming loads. The inspections will be conducted in a manner that allows the inspector to view all contents of the waste load. However, there may be some situations where it is not feasible to view the entire contents of the waste load (e.g., baled wastes). In these situations, the inspector will make an effort to view as much as possible. The inspections will be conducted in an expeditious manner to minimize disruption to normal operations.

8.3 Spill Prevention and Control (§330.227)

The unloading areas have been designed to control and contain spills and contaminated water. Contaminated water generated by the TS will consist of wash water applied to the tipping floor. The tipping floor has been designed to control and contain spills and contaminated water. Contaminated water will be directed to a drain within the tipping floor before it is conveyed to a holding tank. The holding tank will be pumped, as necessary, and hauled to a POTW by a registered hauler.

8.4 Operating Hours (§330.229)

The facility will be authorized to accept and process waste and operate during the timeframes described in this section.

WCLSI, the general public, and other commercial waste transportation companies may utilize this facility for the receipt and processing of waste between the hours of 5:00 a.m. and 7:00 p.m., Monday through Friday and between 7:00 a.m. and 12:00 p.m. on Saturday. Waste acceptance hours for the public will be posted on the entrance sign and will be within the hours listed above. The need for extended hours outside the hours set forth in Title 30 TAC §330.229 is based on waste collection vehicles collecting waste during hours outside the 7:00 a.m. to 7:00 p.m. time frame.

In addition to the waste acceptance hours, heavy equipment operation, transfer trailer loading, and transportation of materials off the site may occur between 1:00 a.m. and 7:00 p.m., Monday through Friday and between 7:00 a.m. and 4:00 p.m. on Saturday. Other non-waste management activities, including administrative and

maintenance activities, do not require specific approval and may occur 24 hours per day, seven days a week.

In addition, the transfer station may request alternative operating hours to accommodate special occasions, special purpose events, holidays, or other special occurrences. The facility will notify the TCEQ regional office in advance for these alternative hours.

When warranted, the facility supervisor will request approval from the commission's regional office to allow additional temporary operating hours to address disaster or other emergency situations, or other unforeseen circumstances (such as traffic delays or adverse weather) that could result in the disruption of waste management services in the area. The facility personnel will document the reason or reasons for the delay for each day on which a delay occurs and place the documentation in the operating record.

The facility will record the dates, time, and duration when any alternative operating hours are utilized. The information will be maintained with the site operating record.

8.5 Facility Sign (§330.231)

A conspicuous sign measuring a minimum four feet by four feet will be maintained at the public entrance to the facility. The sign states, in letters at least three inches high, the following information:

Type of MSW Facility: Type V

Authorized by TCEQ Permit Number: MSW-2420

Hours of Operation for Waste Acceptance:

5:00 a.m. to 7:00 p.m., Monday through Friday

7:00 a.m. to 12:00 p.m. Saturday

Local Emergency Fire Department Number: 911

Other relevant information may also be included on the sign. Waste acceptance hours for both commercial waste haulers and the public may differ from the permitted hours shown above and, if different, will be posted on the facility sign. In no instance will normal waste acceptance hours be outside permitted hours for waste acceptance, listed in Section 8.4.

The sign will be visible and readable from the facility entrance. A sign will be prominently displayed at the facility entrance stating that all loads will be properly covered or otherwise secured, in addition to stating the wastes that are prohibited from receipt at the facility.

8.6 Control of Windblown Material and Litter (§330.233)

Windblown material and litter will be collected and properly managed to control unhealthy, unsafe, or unsightly conditions by the following methods:

- Waste transportation vehicles using this facility will be required to use adequate covers, such as a tarp, net or other means to effectively secure the load consistent with Title 30 TAC §330.235 and Section 8.7. The adequacy of covers or other means to secure incoming wastes will be checked at the facility entrance.
- Windblown material and litter along the entrance road that has accumulated along fences and the Permit boundary and throughout the facility will be collected once a day during facility operations and returned to the facility for processing.
- The TS facility will be a covered structure with two open sides to facilitate the safe and efficient flow of vehicles through the facility. Unloading and loading of waste will be performed completely underneath the structure to control windblown material and litter. The facility will provide litter control devices, as necessary, at appropriate locations near the unloading areas and elsewhere. The litter control devices will be constructed of appropriate materials for the control of windblown material and litter.

8.7 Materials Along the Route to the Facility (§330.235)

The site will take steps to encourage that vehicles hauling waste to the facility are enclosed or provided with a tarp, net, or other means to properly secure the load. These steps are necessary to prevent the escape of any part of the load by blowing or spilling. The facility will provide for the cleanup of waste materials spilled along and within the right-of-way of the public access roads serving the facility for a distance of two miles in either direction from the entrance. Cleanup for the spilled materials will be performed once per day on days when the facility accepts waste. The facility will consult with TxDOT, county, and local government officials concerning cleanup of roads and rights-of-way consistent with Title 30 TAC §330.235.

8.8 Facility Access Roads (§330.223(b) and §330.237)

The entrance road will provide access from FM 1346 Road to the TS for waste hauling vehicles, operating personnel, and visitors. The entrance road will be two lanes with a concrete, asphalt, or aggregate surface from the FM 1346 Road connection. All other internal access roads will be constructed with an all-weather surface. The concrete, asphalt, or aggregate surface entrance, access road, and internal roads will provide mud control for the waste hauling vehicles and transfer trailers prior to exiting the

facility and returning to public access roads. It is not anticipated that mud or other debris will be tracked onto FM 1346 Road given the all-weather surface that will exist on these roads. The onsite access roads will be maintained in a reasonably mud and dust free condition by sweeping and/or periodic water spraying from a water truck dispatched to the site (or from the wash down hose), as necessary. The entrance, access, and internal roads will be maintained in a clean and safe condition. Repairs will be performed as identified during routine inspections.

8.9 Noise Pollution and Visual Screening (§330.239)

Since transfer activities will occur beneath the TS structure, down cast lighting fixtures will be used along walls and in parking areas and WCLSI will install OSHA-approved “white noise” or similar backup alarms on mobile TS equipment as practicable, generated light and noise are mostly confined to the TS facility and waste transfer operations are screened from the public. An 8’ screening fence that will act as a noise barrier may be constructed along portions of the southern, western, and eastern perimeters of the facility. Existing trees and bushes provide screening for the facility. A Facility Screening Plan is shown on Drawing IIIA-5. The facility is located at a sufficient distance from most nearby residences and businesses that activities at the site will not be readily visible. The Permit boundary is approximately 48 feet from the nearest residence, with the TS structure located approximately 180 feet from the nearest residence. The Permit boundary is approximately 130 feet from the nearest business. There are 2 churches and no schools, historic cemeteries, nor aesthetically significant sites within a half mile radius of the facility.

8.10 Overloading and Breakdown (§330.241)

The maximum time waste material will be stored will not exceed 48 hours, except holidays during holidays, waste may be temporarily stored at the facility not to exceed a time period of 72 hours. Waste will not be stored on the transfer station floor at night or on the facility premises after closing hours on Saturdays and Sundays.

If a significant work stoppage should occur at the facility due to a mechanical breakdown or other causes or the site is expected to become inoperable more than 24 hours beyond above listed storage periods, or the site cannot operate in accordance with the SOP, the site will accordingly restrict the receiving of solid waste materials. Under such circumstances, incoming solid waste will be diverted directly to an authorized facility. If the work stoppage is anticipated to last long enough to create nuisance odors, insect breeding, or harborage of vectors, steps will be taken to remove the accumulated solid waste materials from the TS to a properly permitted area landfill.

The TS will be able to store maximum of 2,500 tons of refuse on the tipping floor.

8.11 Sanitation (§330.243)

The tipping floor will be washed down using a pressure washer and/or powered sweeper on a weekly basis.

The tipping floor of the TS building is sloped to direct wash water to the drain within the tipping floor before it is conveyed to a contaminated water storage tank. Wash water will not be allowed to accumulate.

8.12 Ventilation and Air Pollution Control (§330.245)

The transfer station includes a partially enclosed building. Ventilation is provided by the two open north and south) sides and ventilation openings on the east and west walls may be installed. No significant air pollution emissions are expected to result from the operation of the facility. Prior to operations, the appropriate air permit or authorization will be obtained.

If air pollution emission capture and abatement equipment is utilized, it will be properly maintained and operated consistent with Title 30 TAC §330.245(e).

The facility is designed and will be operated to provide adequate ventilation for odor control and employee safety. An odor misting system (using water) will be installed at the facility and used, if needed, along with other measures to suppress nuisance odors from migrating off site. The mist system may also be used to control odors through the addition of chemical deodorizers in the water in nonaqueous odor control systems may be utilized. Air authorization will be obtained from the TCEQ if necessary for the odor control system used. Ponded water will be controlled to avoid objectionable odors.

No liquid waste will be processed or stored at this facility. As noted in Section 5.1, only solid waste will be stored within the TS building.

8.13 Health and Safety (§330.247)

Facility personnel will be trained in accordance with the procedures outlined in Section 2 – Personnel and Training. The general facility safety measures are included in Section 9 – General Instructions.

8.14 Employee Sanitation Facilities (§330.249)

Potable water and sanitary facilities will be provided for all employees and visitors.

8.15 Facility Inspection and Maintenance Schedule

**Table 8-1
Facility Inspection and Maintenance Schedule**

Item	Task	Frequency	Inspector	Type of Inspection
Windblown Waste	Police working area, entrance area, and perimeter fence for loose trash. Clean up as necessary.	Daily	Transfer Station Manager or Designee	Document in the Operating Record
Materials along the Route to the Facility	Police the entrance area and public access roads (i.e., FM 1346) for a distance of 2 miles in either direction from the entrance for litter. Clean up as necessary.	Daily	Transfer Station Manager or Designee	Document in the Operating Record
Facility Access Roads	Inspect facility access road for damage from vehicle traffic, erosion, or excessive mud accumulation.	Weekly	Transfer Station Manager or Designee	Document in the Operating Record
Contaminated Water Holding Tank	Inspect integrity of the cover and check level in tank	Weekly	Transfer Station Manager or Designee	Document in the Operating Record and Coordinate Contaminated Water Removal Per Section 8.3

9 GENERAL INSTRUCTIONS

9.1 General Facility Safety

Facility safety will be promoted by personnel using well-maintained TS equipment to perform standard work procedures. Facility safety will be enhanced by limiting access to the working areas to only authorized personnel. In the event of an emergency, planned emergency response procedures will be followed.

Access to the facility will be limited to authorized personnel as described in Section 8 of this SOP. Access is controlled by a combination of signs and physical barriers. Facility personnel are responsible to be alert for the entrance of unauthorized personnel or the entrance of authorized personnel into prohibited areas.

In the event of an emergency, facility personnel will assess the situation, notify the Transfer Station Manager or designated supervisor, and take appropriate actions such as rendering aid, calling for assistance, or closing access to the emergency scene. Emergency numbers will be posted beside the telephone in the gatehouse.

These include:

Office	Phone
Ambulance	911
San Antonio Fire Department	911
San Antonio Police Department	911
Bexar County. Sheriff Department	911

**SAN ANTONIO TRANSFER STATION
BEXAR COUNTY, TEXAS
TCEQ PERMIT NO. MSW-2420**

TYPE V TRANSFER STATION PERMIT APPLICATION

**PART IV
SITE OPERATING PLAN
APPENDIX IVA
SPECIAL WASTE ACCEPTANCE PLAN**

Prepared for

Waste Connections Lone Star, Inc.

January 2024

Revised May 2024

Prepared by

Weaver Consultants Group, LLC
TBPE Registration No. F-3727
6420 Southwest Boulevard, Suite 206
Fort Worth, Texas 76109
817-735-9770



WCG Project No. 0601-012-11-01

This document is issued for permitting purposes only.

CONTENTS

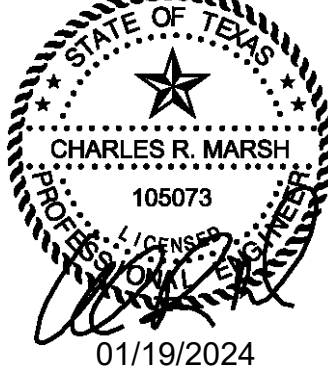
1	INTRODUCTION		IVA-1
2	WASTE ACCEPTANCE		IVA-3
3	OPERATING PROCEDURES		IVA-5
 <u>Tables</u>			
3-1	Special Waste Processing Procedures		IVA-6

1 INTRODUCTION

This Waste Acceptance Plan (WAP) outlines the acceptance requirements and review and approval process that will be used to accept special waste, as defined by the Texas Commission on Environmental Quality (TCEQ) for transfer at the San Antonio Transfer Station (TS). The operator of the transfer station is Waste Connections Lone Star, Inc.

The TCEQ solid waste regulations define a special waste as “any solid waste or combination of solid wastes that because of its quantity, concentration, physical, or chemical characteristics, or biological properties requires special handling and disposal to protect the human health or the environment.”

Only those special wastes specifically listed below will be accepted at this facility without prior written approval from the Executive Director. Any requests for approval of other special waste shall be in accordance with Title 30 Texas Administrative Code (TAC) §330.171(b). The following special wastes may be accepted at this facility.

- Dead animals and slaughterhouse waste that are incidental to routine collection of municipal solid waste and that can be systematically processed along with other municipal solid waste.
- Drugs, contaminated foods, or contaminated beverages other than those contained in normal household waste.
- Empty containers which have been used for pesticides, herbicides, fungicides or rodenticides will be accepted for disposal provided the containers have been triple rinsed, crushed or rendered unusable upon receipt at the gate.
- Incidental amounts of non-regulated asbestos-containing materials (NRACM). The incidental amount is defined as the maximum of 10 percent of the waste received on an annual basis by scale weight (annual basis is defined as the latest 4 consecutive quarters).
- Waste from oil, gas, and geothermal activities subject to regulation by the Railroad Commission of Texas when those wastes are to be processed, treated, or disposed of at a municipal solid waste management facility. Only those wastes authorized for disposal at a municipal solid waste management facility will be accepted.
- Waste generated outside the boundaries of Texas that contains any industrial waste; any waste associated with oil, gas, and geothermal exploration,

production, or development activities; or any material that is listed in the bullets above.

- Other waste than as described above and approved for acceptance by the Executive Director.

No special waste shall be received at the facility unless it is compatible with the compaction and loading equipment operated at the facility or unless modifications are made to the facility to accommodate the special waste. Any changes in operations must be approved in writing by the Executive Director of the TCEQ prior to implementation.

The following wastes will not be accepted at this facility:

- Regulated hazardous waste
- PCBs
- Liquid Wastes
- Certain special wastes, including:
 - hazardous waste from conditionally exempt small-quantity generators that may be exempt from full controls under Title 30 TAC Chapter 335, Subchapter N (relating to Household Materials Which Could Be Classified as Hazardous Wastes);
 - Class 1 industrial nonhazardous waste;
 - untreated medical waste;
 - municipal wastewater treatment plant sludges, other types of domestic sewage treatment plant sludges, and water-supply treatment plant sludges;
 - septic tank pumpings;
 - grease and grit trap wastes;
 - wastes from commercial or industrial wastewater treatment plants; air pollution control facilities; and tanks, drums, or containers used for shipping or storing any material that has been listed as a hazardous constituent in 40 CFR, Part 261, Appendix VIII but has not been listed as a commercial chemical product in 40 CFR §261.33(e) or (f);
 - Soil contaminated by petroleum products, crude oils, or chemicals in concentrations of greater than 1,500 milligrams per kilogram total petroleum hydrocarbons; or contaminated by constituents of concern that exceed the concentrations listed in Table 1 of §335.521(a)(1).
 - incinerator ash;
 - used oil;
 - lead acid storage batteries; and
 - used-oil filters from internal combustion engines.

2 WASTE ACCEPTANCE

Prior to being accepted at the San Antonio TS, special wastes must be preapproved by the landfill that will be receiving the waste, in accordance with the receiving landfill's special waste screening and acceptance procedures. Special waste evaluation and approval will take place prior to delivery of the waste to the transfer station. Typically, the special waste analyst for the landfill will utilize information provided by the generator (e.g., waste-specific chemical and characteristic information or process knowledge information) to determine the acceptability of a waste for disposal at the landfill. The special waste analyst will be responsible for maintaining and utilizing current regulatory guidelines and constituent limits for evaluation of wastes. The special waste analyst also will be responsible for knowing and applying applicable future changes to state and federal disposal regulations, review and acceptance procedures. This information will be provided to transfer station personnel prior to waste acceptance at the transfer station.

The preceding special waste review procedures will include the following.

- The Special Waste Profile (SWP) sheet or waste profile document will be reviewed for completeness. The review will include:
 - The SWP must be completely and legibly filled out by the generator of the waste with all appropriate addresses, contact names, phone and fax numbers, and signatures.
 - The “Waste Stream Information” must include sufficient information to provide the special waste analyst a clear understanding of the waste’s type, origin, shipping method, and anticipated frequency of disposal. This information will be used by the special waste analyst to compare the waste with the appropriate state and federal regulations. If the description is not explicit, additional information will be requested of the generator. The “Physical Characteristics of Waste” must include information on the chemical and physical properties of the waste sufficient to allow the special waste analyst to identify the waste, and correlate the waste properties to the appropriate state and Federal regulations.
 - The generator will provide analytical data to the transfer station showing the results of the analytical testing used to comply with §330.203(c)(2) and RG-003 for wastes regulated by the Railroad Commission and related wastes.

- **Site Specific Evaluation** – It will be confirmed that all special waste acceptance is acceptable in accordance with the following: (1) TCEQ and local regulations and (2) landfill permits. The special waste analyst may request additional information from the generator before rendering a decision. This may include additional analytical, process description, MSDS, or other applicable information.

As noted in Section 8.21 of the SOP, site personnel at the facility will visually compare the material presented for disposal to the SWP to confirm that the physical characteristics (i.e., color, odor, and appearance) of the material match those detailed on the SWP. In the event that the physical characteristics of the waste differ from the approved waste stream, the waste load will be rejected. The generator will be notified of the reasons for rejecting the load. Additional process and chemical analyses may be required to further characterize the waste.

In accordance with Title 30 TAC §330.219(B)(b), the facility will maintain all documents, manifests, shipping documents, trip tickets, etc., involving special waste.

3 OPERATING PROCEDURES

The TS personnel will exercise appropriate care and safeguards when processing special wastes. Specific handling/disposal procedures are detailed in Table 3-1 for the special wastes that will be processed at this TS.

Drivers of transfer trucks containing special waste will provide the required documentation to the receiving landfill concerning the special waste contained within the transfer trailer. The landfill will be responsible to ensure the transferred special waste is disposed of in accordance with the landfill's permit.

**Table 3-1
Special Waste Processing Procedures**

Special Waste	Special Handling Procedures
Slaughterhouse waste and dead animals	Slaughterhouse waste consisting primarily of trash and shipping/package waste will be accepted. Also, dead animals that are incidental to routine collection of municipal solid waste and that can be systematically processed along with other municipal solid waste will be accepted at this facility. This waste may contain some animal remains; however, this facility will not accept bulk quantities of dead animals or animal remains in a specific shipment or load. All slaughterhouse waste, including contaminated packaging materials, and dead animals will be processed upon receipt or covered with a minimum of three feet of municipal solid waste until it is processed into transfer trailers. The tipping floor and equipment will be cleaned at the end of each day when special waste containing dead animals or slaughterhouse waste is processed.
Drugs and contaminated foods that are not considered controlled substances	These wastes will be processed into transfer trailers promptly upon receipt. Operators will observe unloading and loading of these waste materials to ensure no scavenging or salvaging of waste. The tipping floor and equipment will be cleaned at the end of each day when special waste containing contaminated food waste is processed.
Empty containers, including paper, cardboard and metal, that have been used for pesticides, herbicides, fungicides or rodenticides	These containers will be processed in the transfer station upon receipt. These containers will not be allowed to accumulate on the tipping floor. All containers received will be handled in accordance with Title 30 TAC §330.171 and will be triple rinsed prior to arrival. If containers cannot be processed upon receipt they will be crushed with the loader and rendered unusable.
Incidental amounts of non-regulated asbestos-containing materials (NRACM)	Loads of primarily NRACM will be transferred directly from the tipping floor of the transfer station into the transfer trailers. The front-end loader will not attempt to compact or travel over the NRACM. These procedures will minimize the handling of NRACM so that the integrity of the material is maintained.
Selected waste from oil, gas, and geothermal activities subject to regulation by the Railroad Commission of Texas	This waste will be accepted at this facility provided the incoming loads are delivered in quantities that will allow the waste to be processed safely and efficiently along with other municipal solid waste. In addition, prior to acceptance at the transfer station, waste acceptance approval information from the landfill that will dispose of this waste will be obtained. The approval information will include all applicable information used to characterize this material. No liquids or sludges will be accepted. This waste material will only be accepted if the requirements set forth in TCEQ RG-003 are met.
Waste generated outside the boundaries of Texas that contains any industrial waste; any waste associated with oil, gas, and geothermal exploration, production, or development activities; or any other special waste that is accepted at the TS	This waste shall be handled in accordance with the provisions outlined above and as indicated within this Special Waste Acceptance Plan for each specific type of waste.